

Product Description

The BSW6622 is an absorptive SPDT 50Ω matched RF switch supporting bandwidth up to 8GHz. It's high linearity performance across the temperature range makes it ideally suitable for use in 3G/4G/5G wireless infrastructure and 802.11 a/n/ac/ax applications where high isolation and excellent performance is required.

The BSW6622 is designed with robust ESD protection circuits at all pins and packaged in an industry standard, fully RoHS2-compliant, 20Lead, 4mm x 4mm x 0.9mm QFN package.

The BSW6622 does not require blocking capacitors. If DC is presented at the RF port, add a blocking capacitor.

A functional block diagram is shown in Figure 1.

Block Diagram

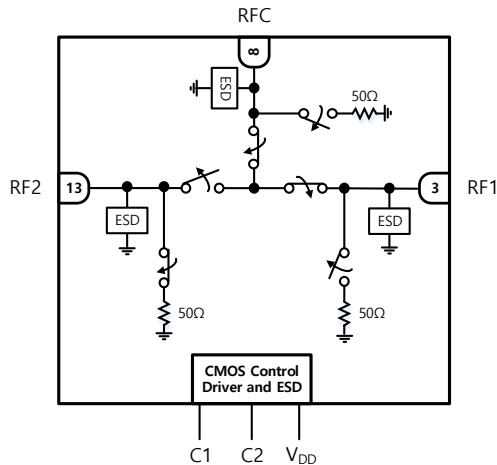

Figure 1. Functional Block Diagram

Applications

- Wireless 3G/4G/5G Infrastructure
- Base station & Repeater
- WLAN 802.11 a/b/ac/ax

Package Type



4mm x 4mm x 0.9mm, 20-Lead QFN Package

Figure 2. Package type

Device Features

- Output frequency range : 5MHz to 8.0GHz
- Supply Voltage : 2.7V to 5.5V
- ESD, HBM : ±1.5kV @All pins
- Operating temperature range : -40°C to +105°C
- Low Insertion Loss
 - : 0.73dB @ 2GHz
 - : 0.87dB @ 4GHz
 - : 1.07dB @ 6GHz
- Ultra High Isolation
 - RFC to RFx
 - : 62dB @ 2GHz
 - : 58dB @ 4GHz
 - : 48dB @ 6GHz
 - RFx to RFx
 - : 82dB @ 2GHz
 - : 72dB @ 4GHz
 - : 64dB @ 6GHz
- Switching time : 120 to 220ns
- 20-Lead QFN package : 4.0mm x 4.0mm x 0.9mm
- Lead-free/RoHS2 compliant QFN package

Electrical Specifications

Typical conditions are at VDD = 5V, T_A = 25°C, C1/C2 Low = 0V, C1/C2 High = 3.3V, Z_L = 50Ω, Excluding SMA Connector and PCB losses⁽¹⁾, unless otherwise noted.

Table 1. Electrical Specifications

Parameter	Path	Condition	Min	Typ	Max	Unit
Operating Frequency			5		8000	MHz
Insertion Loss	RFC - RFx	1GHz		0.68		dB
		2GHz		0.73		
		3GHz		0.83		
		4GHz		0.87		
		6GHz		1.10		
		8GHz		1.98		
Isolation (C to X)	RFC - RFx	1GHz		67		dB
		2GHz		62		
		3GHz		60		
		4GHz		58		
		6GHz		48		
		8GHz		46		
Isolation (X to X)	RFx - RFx	1GHz		91		dB
		2GHz		82		
		3GHz		76		
		4GHz		72		
		6GHz		64		
		8GHz		58		
Return Loss (Active Port)	RFC / RF1 / RF2	5MHz–6GHz 6GHz–8GHz		20 / 23/ 23 14 / 13/ 13		dB
Return Loss (Terminated Port)	RFC / RF1 / RF2	5MHz–6GHz 6GHz–8GHz		24 / 25/ 25 14 / 15/ 15		dB
Input P1dB	RFC - RFx	2.35GHz		36		dBm
		3.5GHz		36		
		4.9GHz		34		
Input IP2 ⁽²⁾	RFC - RFx	2.35GHz		108		dBm
		3.5GHz		105		
		4.9GHz		100		
Input IP3 ⁽²⁾	RFC - RFx	2.35GHz		64		dBm
		3.5GHz		64		
		4.9GHz		65		
2nd Harmonics ⁽³⁾	RFC - RFx	2.35GHz		95		dBc
		3.5GHz		90		
		4.9GHz		80		
3rd Harmonics ⁽³⁾	RFC - RFx	2.35GHz		100		dBc
		3.5GHz		101		
		4.9GHz		95		
Switching time	RFC - RFx	50% CTRL to 90% RF		220		ns
		50% CTRL to 10% RF		120		

The typical spurious performance of the BSW6622 is under –140dBm / 10Hz @ Over 10MHz

(1)Excluding SMA Connector and PCB loss.

1GHz (0.17dB), 2GHz (0.26dB), 3GHz (0.35dB), 4GHz (0.41dB), 5GHz (0.45dB), 6GHz (0.56dB), 7GHz (0.61dB), 8GHz (0.60dB)

(2)The each-tone Power is 20dBm and Tone spacing is 1MHz.

(3)The each-tone Power is 20dBm.

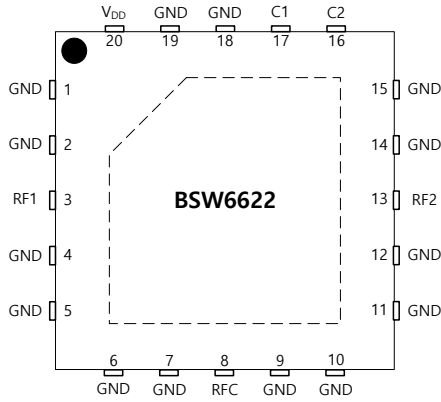
Product Description

Figure 3. Pin Description
Table 2. Pin Description

Pin No.	Pin Name	Description
1, 2, 4, 5, 6, 7, 9, 10, 11, 12, 14, 15, 18, 19	GND	Ground
3	RF1	RF1 Port
8	RFC	RFC Port
13	RF2	RF2 Port
16	C2	Switch Control Input (Definition for the C2 pin, See Table 3)
17	C1	Switch Control Input (Definition for the C1 pin, See Table 3)
20	VDD	Supply Voltage
Pad	Exposed Pad	Ground

Table 3. Control Truth Table

C1	C2	RFC-RF1	RFC-RF2
0	0	OFF	OFF
0	1	OFF	ON
1	0	ON	OFF
1	1	N/A	N/A

Table 4. Operating Ranges

Parameter	Symbol	Min	Typical	Max	Unit
Supply Voltage	VDD	2.7	5	5.5	V
Supply Current	IDD	-	210	-	μA
Digital Input Control (C1/C2)	C _{High}	1.0	-	3.3	V
	C _{Low}	0	-	0.7	V
Operating Temperature Range	T _O	-40	25	105	°C
RF Input Power, CW	P _{CWOP}	-	-	30	dBm

Table 5. Absolute Maximum Ratings

Parameter		Symbol	Min	Max	Unit
Supply Voltage		VDD	-0.3	5.5	V
Digital Input Voltage		C1 / C2	-0.3	3.6	V
Maximum Input Power, CW (+25°C)		RF _{CWMAX}	-	Input P1dB	dBm
Storage Temperature Range		T _{ST}	-65	150	°C
ESD	HBM	ALL pins	V _{ESDHBM}	±1500	V
	CDM	ALL pins	V _{ESDCDM}	±1000	V

Typical Performances

Typical conditions are at VDD = 5V, T_A = 25°C, C1/C2 Low = 0V, C1/C2 High = 3.3V, Z_L = 50Ω, Excluding SMA Connector and PCB losses, unless otherwise noted.

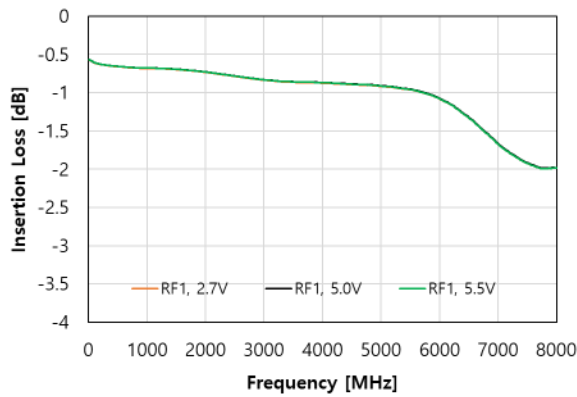
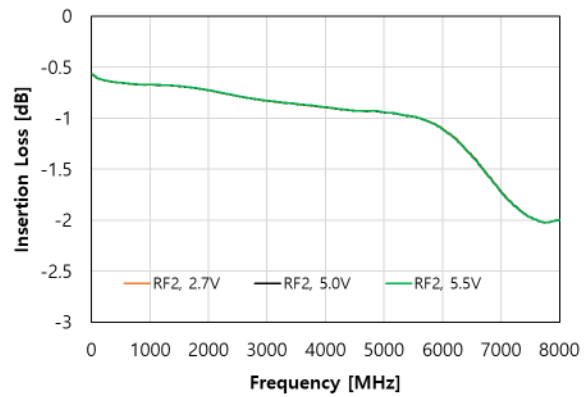
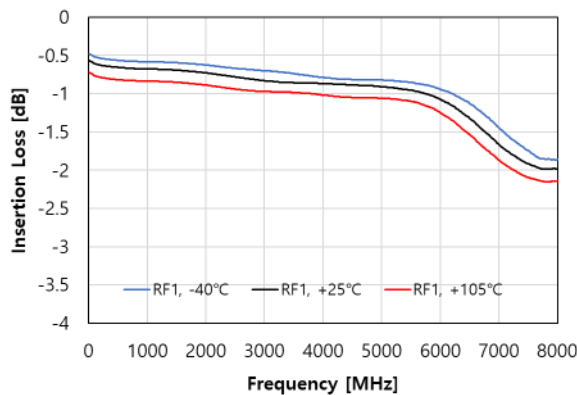
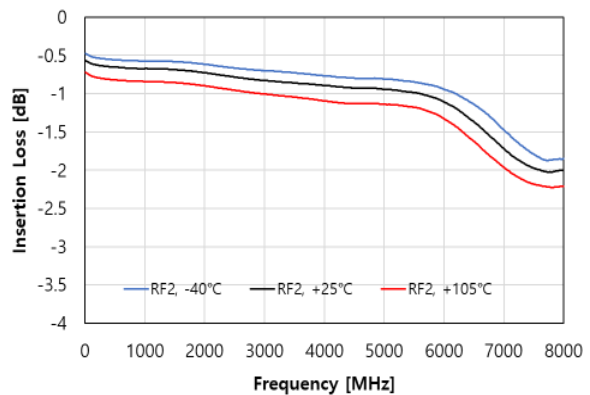
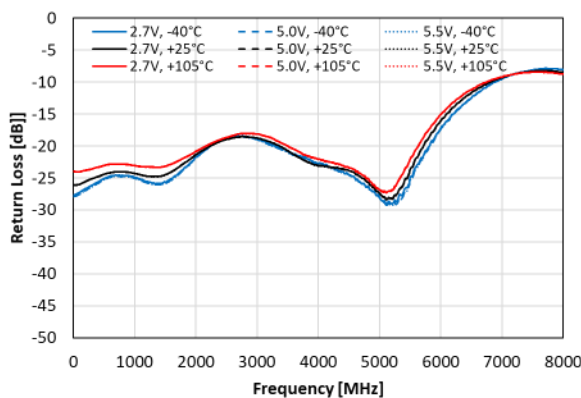
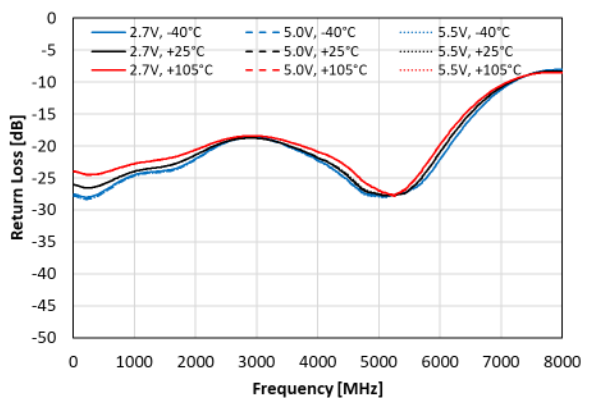
Figure 4. Insertion Loss vs VDD [RFC to RF1]

Figure 5 Insertion Loss vs VDD [RFC to RF2]

Figure 6. Insertion Loss vs Temp [RFC to RF1]

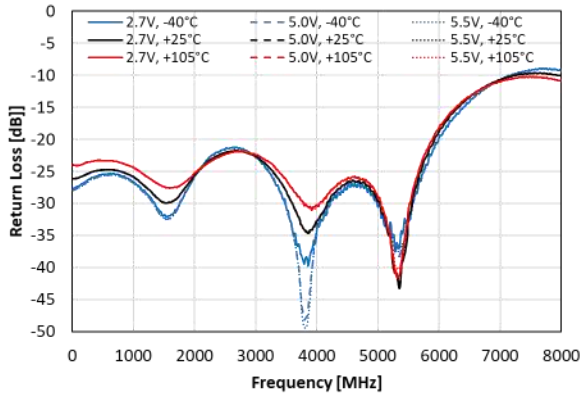
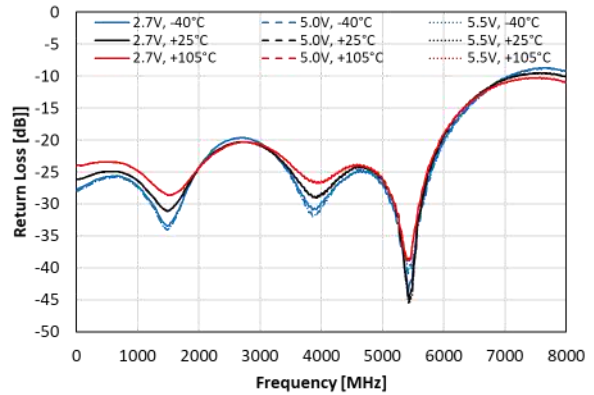
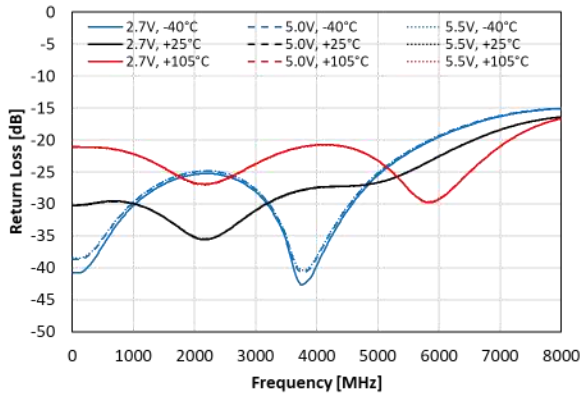
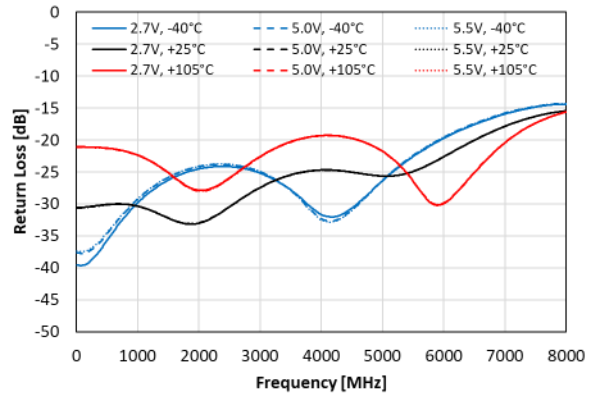
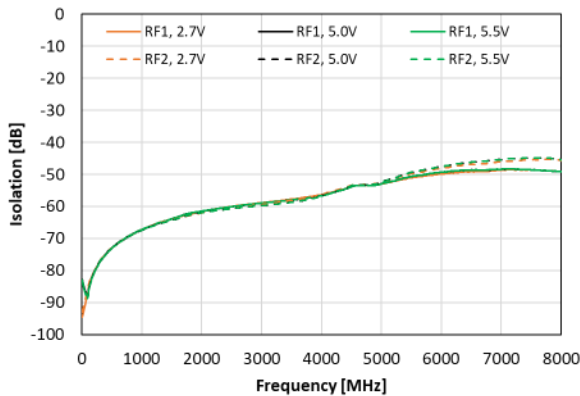
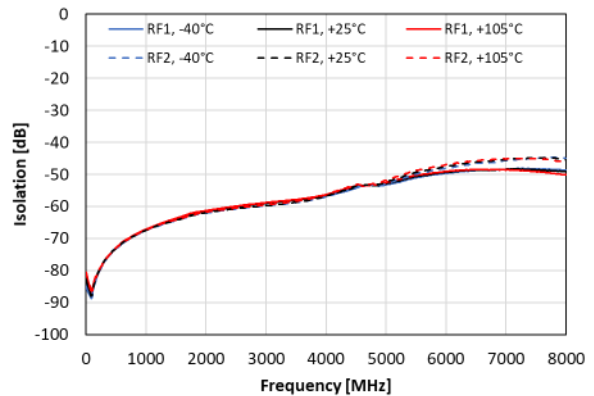
Figure 7. Insertion Loss vs Temp [RFC to RF2]

Figure 8. RFC Port Return Loss vs Temp [RF1 On state]

Figure 9. RFC Port Return Loss vs Temp [RF2 On state]

Typical Performances

Typical conditions are at VDD = 5V, T_A = 25°C, C1/C2 Low = 0V, C1/C2 High = 3.3V, Z_L = 50Ω, Excluding SMA Connector and PCB losses, unless otherwise noted.

Figure 10. RF1 Port Return Loss vs Temp [On state]

Figure 11. RF2 Port Return Loss vs Temp [On state]

Figure 12. RF1 Port Return Loss vs Temp [Off state]

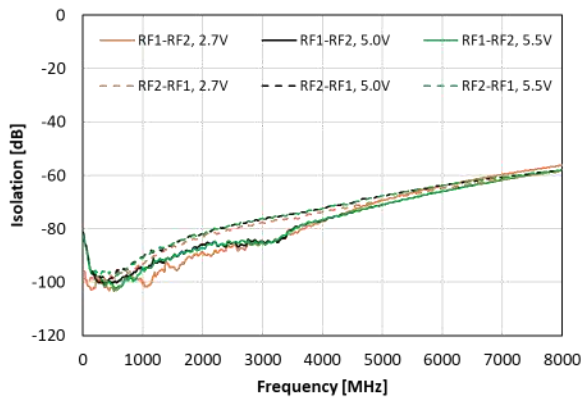
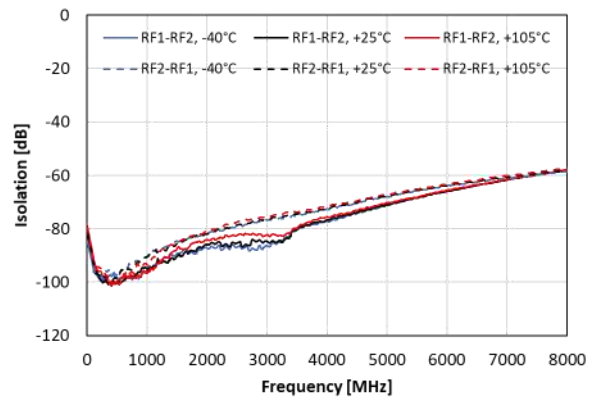
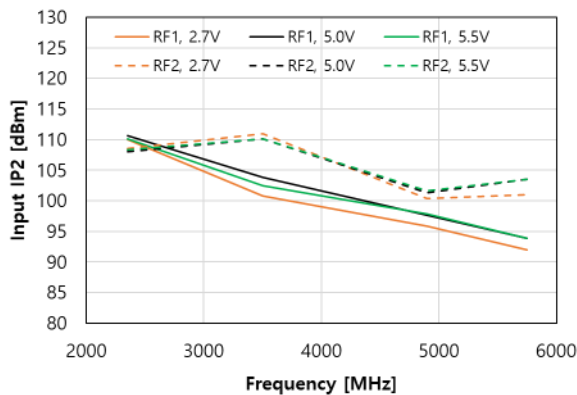
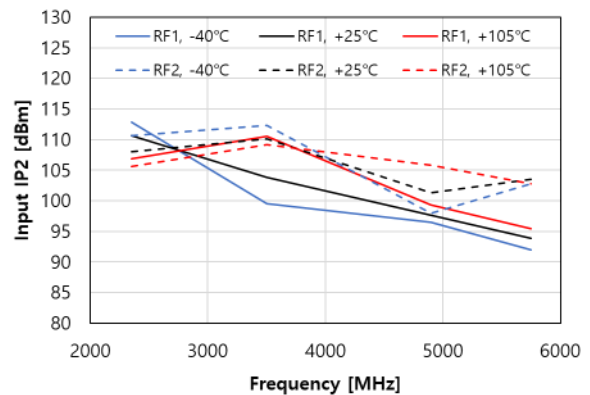
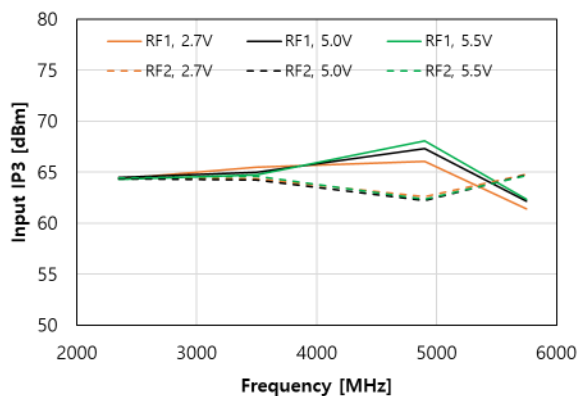
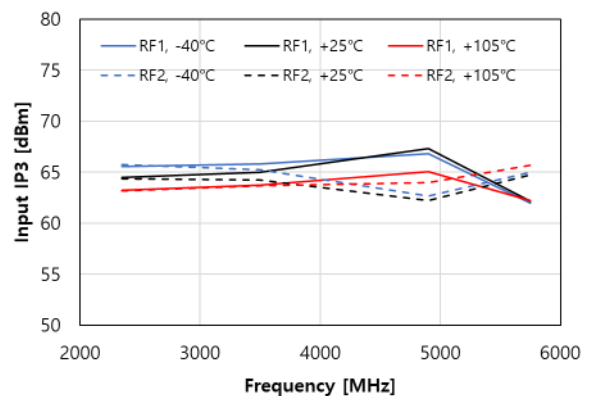
Figure 13. RF2 Port Return Loss vs Temp [Off state]

Figure 14. Isolation vs VDD [RFC to RFx]

Figure 15. Isolation vs Temp [RFC to RFx]

Typical Performances

Typical conditions are at VDD = 5V, T_A = 25°C, C1/C2 Low = 0V, C1/C2 High = 3.3V, Z_L = 50Ω, Excluding SMA Connector and PCB losses, unless otherwise noted.

Figure 16. Isolation vs VDD [RFx to RFx]

Figure 17. Isolation vs Temp [RFx to RFx]

Figure 18. Input IP2 vs VDD [RFC to RFx]

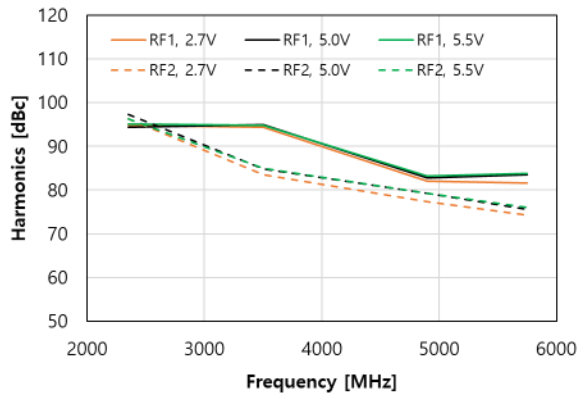
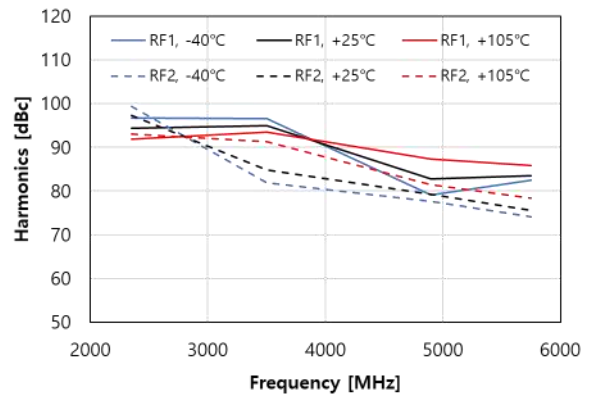
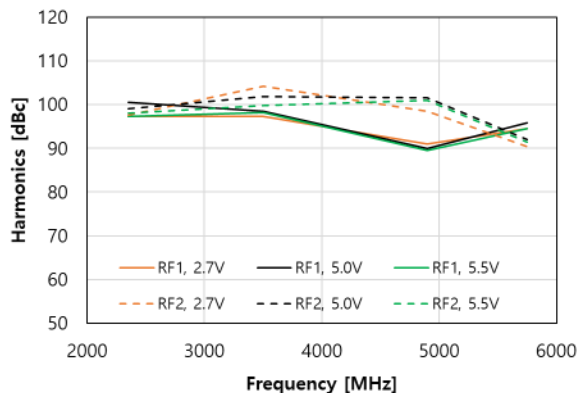
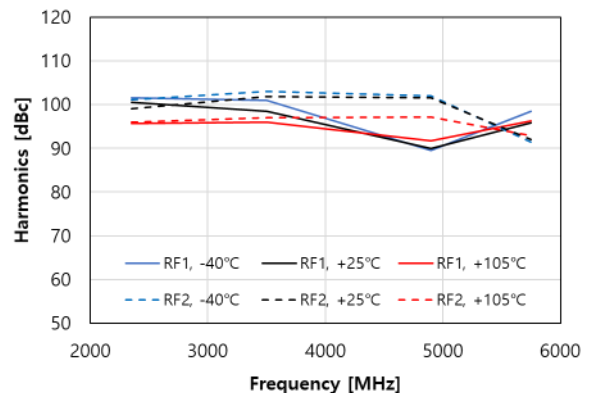
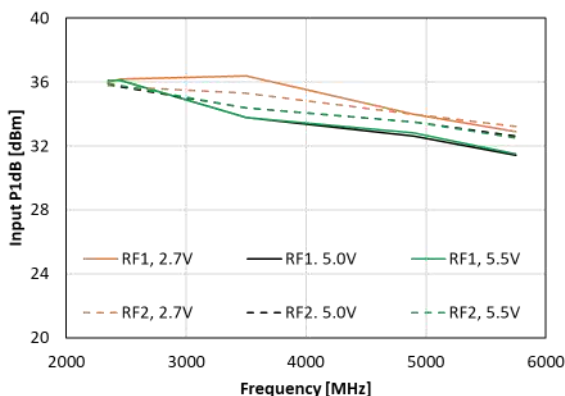
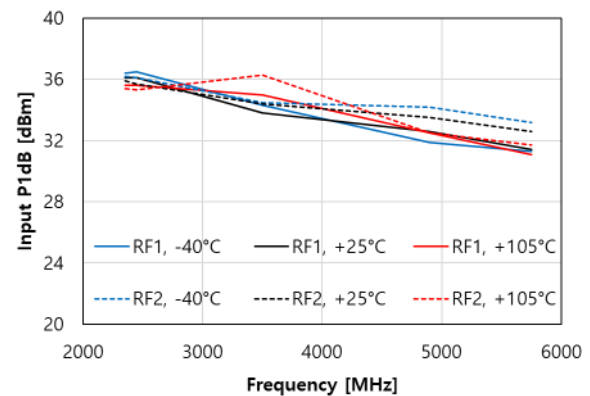
Figure 19. Input IP2 vs Temp [RFC to RFx]

Figure 20. Input IP3 vs VDD [RFC to RFx]

Figure 21. Input IP3 vs Temp [RFC to RFx]

Typical Performances

Typical conditions are at VDD = 5V, T_A = 25°C, C1/C2 Low = 0V, C1/C2 High = 3.3V, Z_L = 50Ω, Excluding SMA Connector and PCB losses, unless otherwise noted.

Figure 22. 2nd Harmonic vs VDD [RFC to RFx]

Figure 23. 2nd Harmonic vs Temp [RFC to RFx]

Figure 24. 3rd Harmonic vs VDD [RFC to RFx]

Figure 25. 3rd Harmonic vs Temp [RFC to RFx]

Figure 26. Input P1dB vs VDD [RFC to RFx]

Figure 27. Input P1dB vs Temp [RFC to RFx]

Preliminary Datasheet

Evaluation Board

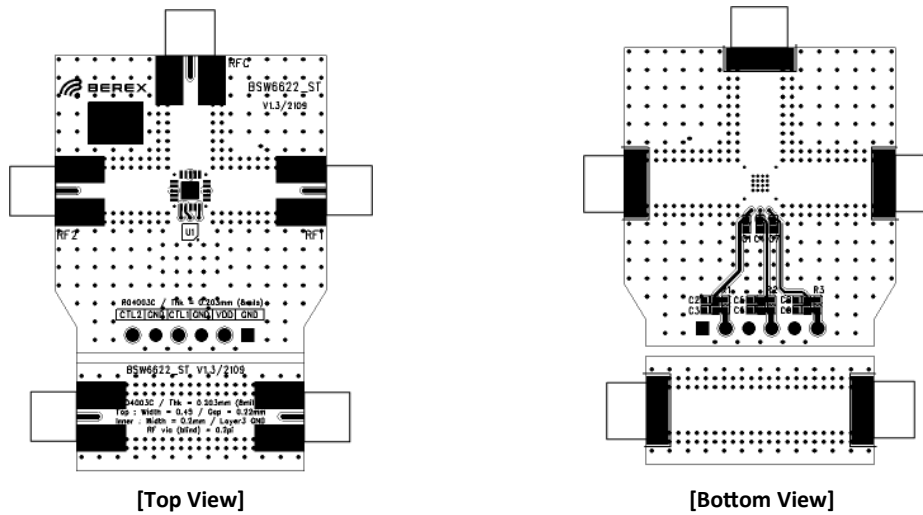

Figure 28. Evaluation Board Layout

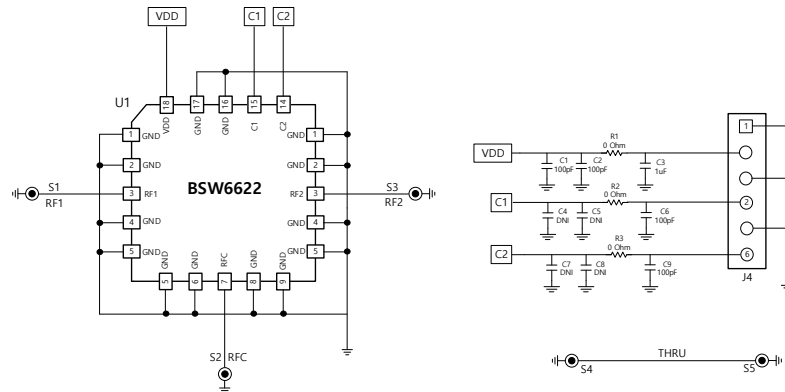

Figure 29. Evaluation Board Schematic

Table 6. Bill of Material - Evaluation Board

No.	Ref Des	Part Qty	Part Number	Remark
1	C1,C2,C6,C9	4	CAP 1005 100pF J 50V	C1 should be placed near the BSW6622
2	C3	1	CAP 1005 1uF J 50V	
3	C4,C5,C7,C8	4	CAP 1005 DNI	
4	R1,R2,R3	3	RES 1005 0 ohm	
5	J4	1	6 Pin Header 2.54mm	
5	S1,S2,S3,S4,S5	5	SMA_END_LAUNCH	
7	U1	1	BSW6622	

Evaluation Board

Preliminary Datasheet

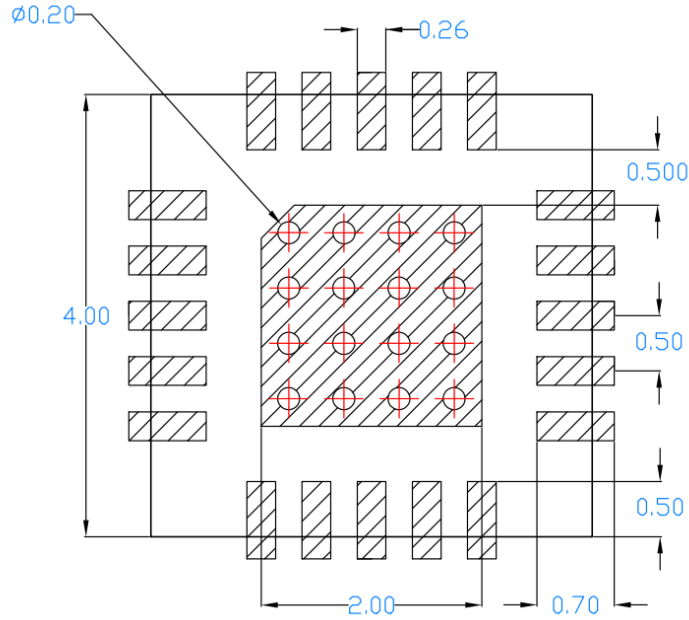
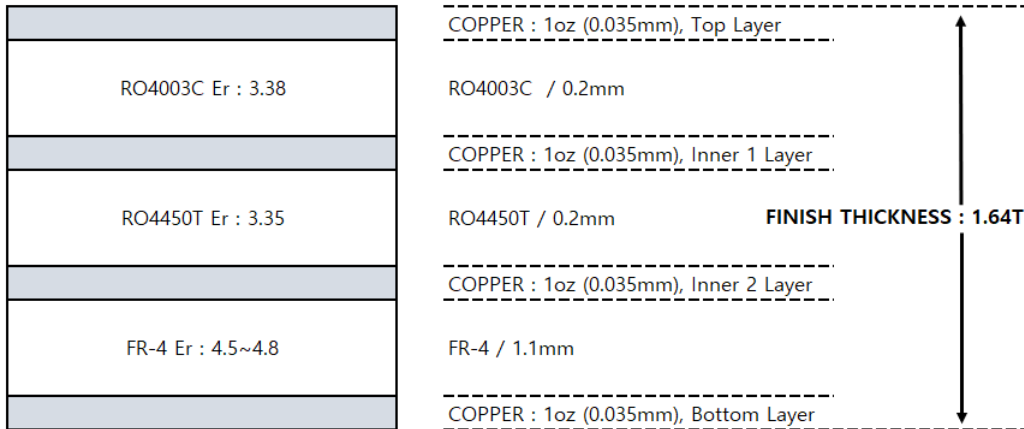
Figure 30. Suggested PCB Land Pattern

Figure 31. Evaluation Board PCB Layer Information

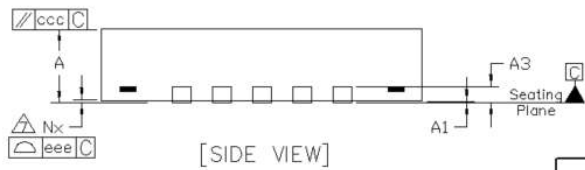
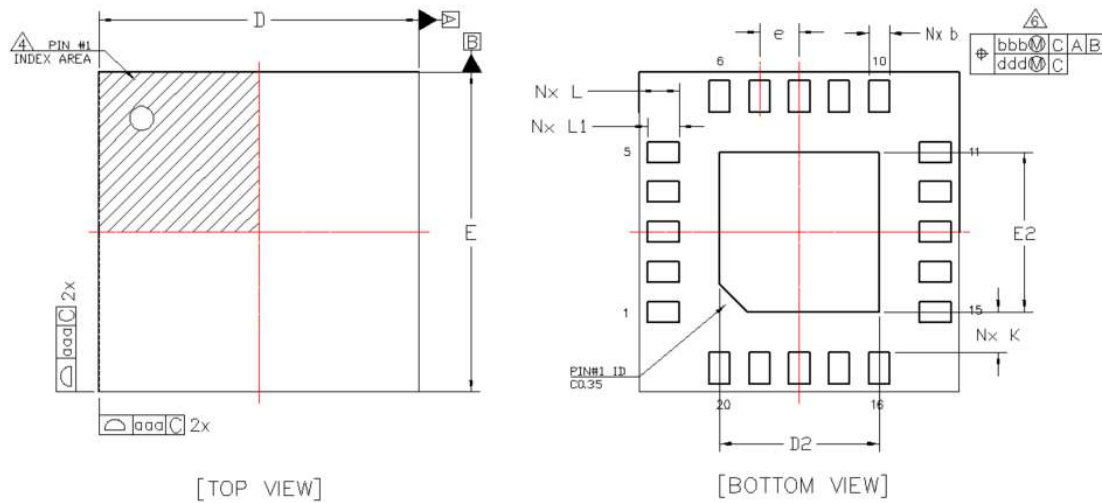
Package Outline Drawing



NOTES:

1. Dimensioning and tolerancing conform to ASME Y14.5–2009.
 2. All dimensions are in millimeters.
 3. N is the total number of terminals.
 4. The location of the marked terminal #1 identifier is within the hatched area.
 5. ND and NE refer to the number of terminals each D and E side respectively.
- ⚠ Dimension b applies to the metallized terminal and is measured between 0.15mm and 0.3mm from the terminal tip. If the terminal has a radius on the other end of it, dimension b should not be measured in that radius area.
- ⚠ Coplanarity applies to the terminals and all other bottom surface metallization.

Dimension Table					
Synbel	Thickness	Min	Nominal	Max	Note
A		0.80	0.90	1.00	
A1		0.00	0.02	0.05	
A3		---	0.203 Ref.	---	
b		0.21	0.26	0.31	6
D			4.00 BSC		
E			4.00 BSC		
e			0.50 BSC		
D2		1.95	2.00	2.05	
E2		1.95	2.00	2.05	
K		0.20	---	---	
L1		0.35	0.40	0.45	
L		0.40	0.50	0.60	
aaa			0.05		
bbb			0.10		
ccc			0.10		
ddd			0.05		
eee			0.08		
N			20		3
ND			5		5
NE			5		5
NOTES			1,2		

Figure 32. Package Outline Dimension

Preliminary Datasheet

Tape & Reel

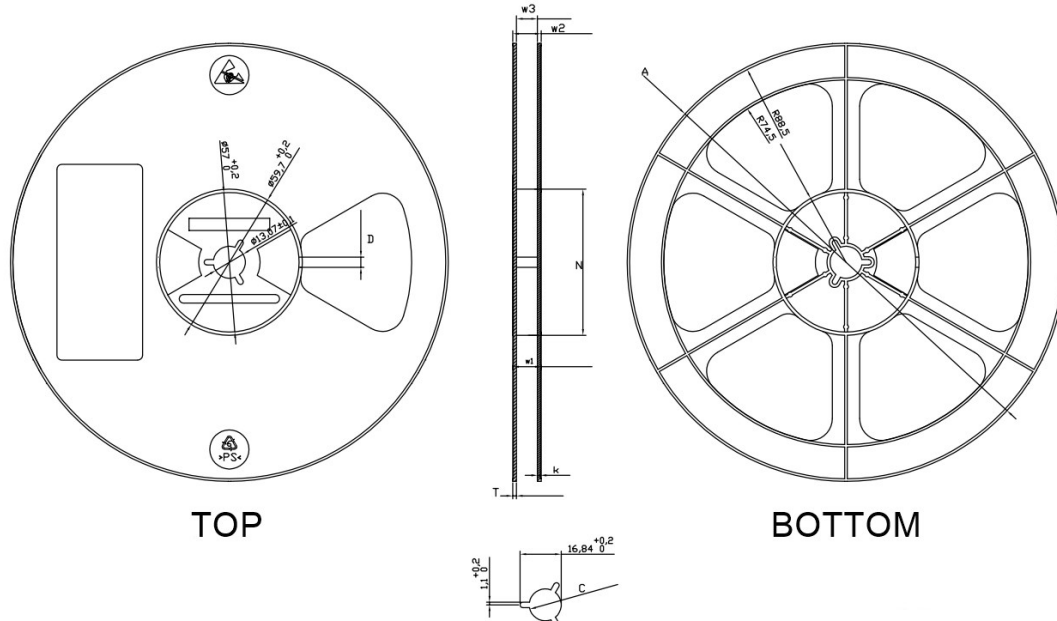

TYPE	A	N	C	D	w1	w2	w3	T	k
12MM	$\phi 180^{+2}$	$\phi 60^{+1}$	$\phi 13.1^{-0.2}$	4.2 ± 0.5	12.5^{-0}	15.7^{-1}	12.7^{-1}	1.5 ± 0.15	1.2 ± 0.1

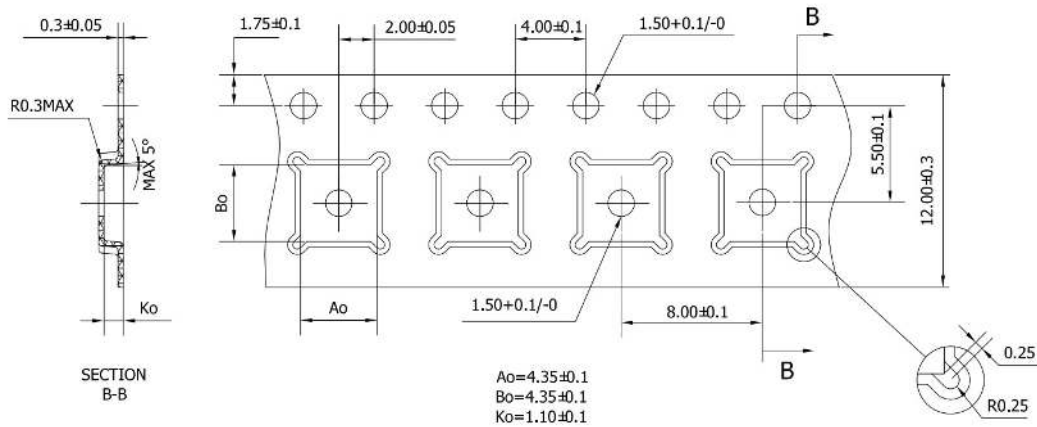

NOTES:
 1 SPROCKET HOLE FITCH CUMULATIVE TOLERANCE ± 0.2
 2 CAMBER IN COMPLIANCE WITH EIA-481
 3 POCKET POSITION RELATIVE TO SPROCKET HOLE MEASURED AS TRUE POSITION OF POCKET, NOT POCKET HOLE

Packaging information:	
Tape Width	12mm
Reel Size	7inch
Device Cavity Pitch	8mm
Device Per Reel	1000EA

Figure 33. Tape & Reel Information

Package Marking

Marking information:	
BSW6622	Device Name
YY	Year
WW	Work Week
XX	Wafer Lot Number

Figure 34. Package Marking
Lead plating finish
100% Tin Matte finish

(All BeRex products undergoes a 1 hour, 150 degree C, Anneal bake to eliminate thin whisker growth concerns.)

MSL / ESD Rating

ESD information1 :	
Rating	Class 1C ($\pm 1500V$)
Test	Human Body Model (HBM)
Standard	JEDEC Standard JS-001-2017

ESD information2 :	
Rating	Class C3 ($\pm 1000V$)
Test	Charged Device Model (CDM)
Standard	JEDEC Standard JS-002-2018

MSL information:	
Rating	Level 1 at +260°C convection reflow
Standard	JEDEC Standard J-STD-020



Proper ESD procedures should be followed when handling the device.

RoHS Compliance

This part is compliant with Restrictions on the use of certain Hazardous Substances in Electrical and Electronic Equipment (RoHS) Directive 2011/65/EU as amended by Directive 2015/863/EU.

This product also is compliant with a concentration of the Substances of Very High Concern (SVHC) candidate list which are contained in a quantity of less than 0.1%(w/w) in each components of a product and/or its packaging placed on the European Community market by the BeRex and Suppliers.

NATO CAGE code:

2	N	9	6	F
----------	----------	----------	----------	----------