

---

## *DMOS Dual Full-Bridge PWM Motor Driver*

---

### **Last Time Buy**

These parts are in production but have been determined to be LAST TIME BUY. This classification indicates that the product is obsolete and notice has been given. Sale of this device is currently restricted to existing customer applications. The device should not be purchased for new design applications because of obsolescence in the near future. Samples are no longer available.

Date of status change: November 2, 2009

Deadline for receipt of LAST TIME BUY orders: April 30, 2010

#### **Recommended Substitutions:**

*For existing customer transition, and for new customers or new applications, refer to the [A3992](#).*

---

NOTE: For detailed information on purchasing options, contact your local Allegro field applications engineer or sales representative.

---

*Allegro MicroSystems, Inc. reserves the right to make, from time to time, revisions to the anticipated product life cycle plan for a product to accommodate changes in production capabilities, alternative product availabilities, or market demand. The information included herein is believed to be accurate and reliable. However, Allegro MicroSystems, Inc. assumes no responsibility for its use; nor for any infringements of patents or other rights of third parties which may result from its use.*

---

## DMOS Dual Full-Bridge PWM Motor Driver

### Features and Benefits

- ±1.5 A, 50 V continuous output rating
- Low  $r_{DS(on)}$  DMOS output drivers
- Programmable slow, fast, and mixed current-decay modes
- Serial-interface controls chip functions
- Synchronous rectification for low power dissipation
- Internal UVLO and thermal shutdown circuitry
- Crossover-current protection
- Sleep and idle modes

### Package: 44-pin PLCC with internally fused pins (suffix ED)

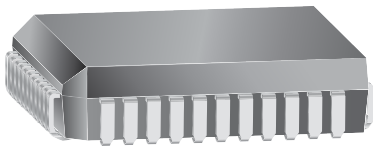

Not to scale

### Description

Designed for pulse width modulated (PWM) current control of two DC motors, the A3974 is capable of output currents to ±1.5 A and operating voltages to 50 V. Internal fixed off-time PWM current-control timing circuitry can be programmed via a serial interface to operate in slow, fast, and mixed current-decay modes.

Independent ENABLE input terminals are provided for use in controlling the speed and torque of each DC motor with externally applied PWM control signals.

Synchronous rectification circuitry allows the load current to flow through the low  $r_{DS(on)}$  of the DMOS output driver during the current decay. This feature will eliminate the need for external clamp diodes in most applications, saving cost and external component count, while minimizing power dissipation.

Internal circuit protection includes thermal shutdown with hysteresis, undervoltage monitoring of  $V_{DD}$  and the charge pump, and crossover-current protection. Special power-up sequencing is not required.

The A3974 is supplied in a 44-pin plastic PLCC with 3 internally fused pins on each side, for maximum heat dissipation. The fused pins are at ground potential and need no electrical isolation.

### Pin-out Diagram

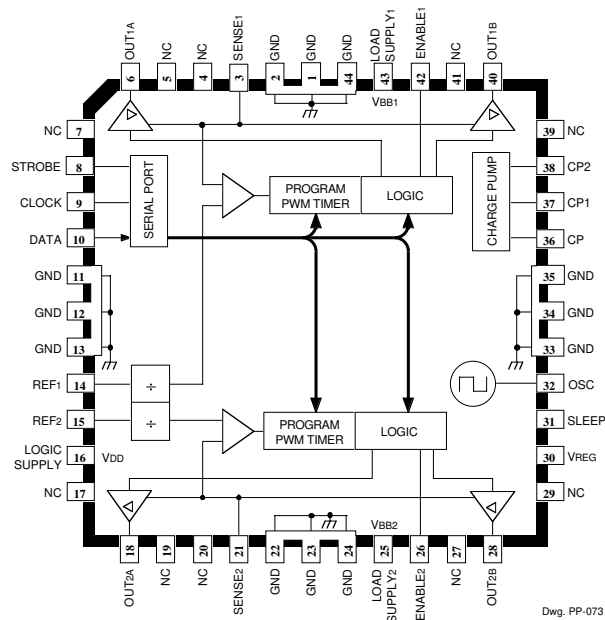

**Selection Guide**

Part Number	Packing
A3974SED-T	27 pieces per tube
A3974SEDTR-T	450 pieces per reel

**Absolute Maximum Ratings**

Characteristic	Symbol	Notes	Rating	Units
Load Supply Voltage	$V_{BB}$		50	V
Logic Supply Voltage	$V_{DD}$		7.0	V
Logic Input Voltage Range	$V_{IN}$	Continuous	$-0.3$ to $V_{DD} + 0.3$	V
		Pulsed, $t_w < 30$ ns	$-1.0$ to $V_{DD} + 1.0$	V
Reference Voltage	$V_{REF}$		3	V
Sense Voltage (DC)	$V_S$	Continuous	0.5	V
		Pulsed, $t_w < 1$ $\mu$ s	2.5	V
Output Current	$I_{OUT}$	Output current rating may be limited by duty cycle, ambient temperature, and heat sinking. Under any set of conditions, do not exceed the specified current rating or a junction temperature of 150°C.	$\pm 1.5$	A
Operating Ambient Temperature	$T_A$	Range S	-20 to 85	°C
Maximum Junction Temperature	$T_J(\text{max})$		150	°C
Storage Temperature	$T_{stg}$		-55 to 150	°C

**Thermal Characteristics** may require derating at maximum conditions, see application information

Characteristic	Symbol	Test Conditions*	Value	Units
Package Thermal Resistance	$R_{\theta JA}$	4-layer PCB based on JEDEC standard	22	°C/W
	$R_{\theta JT}$		6	°C/W

\*Additional thermal information available on the Allegro website.

FUNCTIONAL BLOCK DIAGRAM

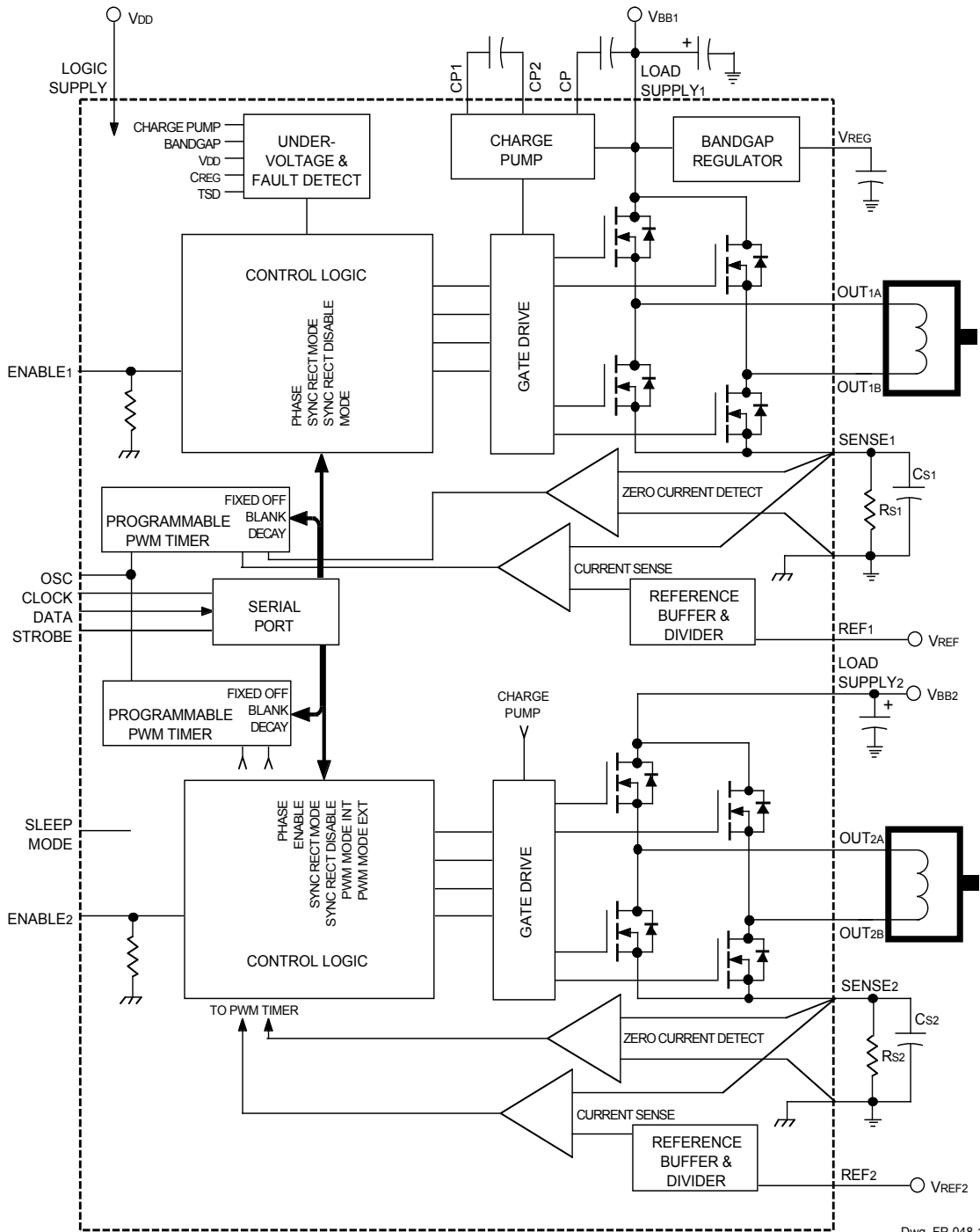

Dwg. FP-048-1

**ELECTRICAL CHARACTERISTICS** at  $T_A = +25^\circ\text{C}$ ,  $V_{BB} = 50\text{ V}$ ,  $V_{DD} = 5.0\text{ V}$ ,  $f_{\text{PWM}} < 50\text{ kHz}$  (unless otherwise noted).

Characteristic	Symbol	Test Conditions	Limits			
			Min.	Typ.	Max.	Units
<b>Output Drivers</b>						
Load Supply Voltage Range	$V_{BB}$	Operating	15	—	50	V
		During sleep mode	0	—	50	V
Output Leakage Current	$I_{DSS}$	$V_{OUT} = V_{BB}$	—	<1.0	20	$\mu\text{A}$
		$V_{OUT} = 0\text{ V}$	—	<-1.0	-20	$\mu\text{A}$
Output ON Resistance	$r_{DS(on)}$	Source driver, $I_{OUT} = -1.5\text{ A}$	—	0.5	0.55	$\Omega$
		Sink driver, $I_{OUT} = 1.5\text{ A}$	—	0.315	0.35	$\Omega$
Body Diode Forward Voltage	$V_F$	Source diode, $I_F = 1.5\text{ A}$	—	—	1.2	V
		Sink diode, $I_F = 1.5\text{ A}$	—	—	1.2	V
Load Supply Current	$I_{BB}$	$f_{\text{PWM}} < 50\text{ kHz}$	—	4.0	7.0	mA
		Charge pump on, outputs disabled	—	2.0	5.0	mA
		Sleep or idle mode	—	—	20	$\mu\text{A}$
<b>Control Logic</b>						
Logic Supply Voltage Range	$V_{DD}$	Operating	4.5	5.0	5.5	V
Logic Input Voltage	$V_{IN(1)}$		2.0	—	—	V
	$V_{IN(0)}$		—	—	0.8	V
Logic Input Current (except ENABLE)	$I_{IN(1)}$	$V_{IN} = 2.0\text{ V}$	—	<1.0	$\pm 20$	$\mu\text{A}$
	$I_{IN(0)}$	$V_{IN} = 0.8\text{ V}$	—	<1.0	$\pm 20$	$\mu\text{A}$
ENABLE Input Current	$I_{EN(1)}$	$V_{EN} = 2.0\text{ V}$	—	40	100	$\mu\text{A}$
	$I_{EN(0)}$	$V_{EN} = 0.8\text{ V}$	—	16	30	$\mu\text{A}$
OSC Input Frequency	$f_{OSC}$		2.9	—	6.1	MHz
OSC Input Duty Cycle	—		40	—	60	%
OSC Input Hysteresis	$\Delta V_{IN}$		200	—	400	mV
Reference Input Voltage Range	$V_{REF}$	Operating	0	—	2.6	V

continued next page ...

**ELECTRICAL CHARACTERISTICS** at  $T_A = +25^\circ\text{C}$ ,  $V_{BB} = 50\text{ V}$ ,  $V_{DD} = 5.0\text{ V}$ ,  $f_{\text{PWM}} < 50\text{ kHz}$  (unless otherwise noted), continued.

Characteristic	Symbol	Test Conditions	Limits			Units
			Min.	Typ.	Max.	
<b>Control Logic (continued)</b>						
Reference Input Current	$I_{\text{REF}}$	$V_{\text{REF}} = 2.6\text{ V}$	—	—	$\pm 1.0$	$\mu\text{A}$
Reference Input Offset Voltage	$V_{\text{IO}}$		—	$\pm 10$	—	mV
Reference Divider Ratio	$V_{\text{REF}}/V_S$	D16 = 1	—	10	—	—
		D16 = 0	—	5.0	—	—
Gain ( $G_m$ ) Error (note 3)	$E_G$	$V_{\text{REF}} = 2.6\text{ V}$ , D16 = 0	—	0	$\pm 4.0$	%
		$V_{\text{REF}} = 0.5\text{ V}$ , D16 = 0	—	0	$\pm 14$	%
		$V_{\text{REF}} = 2.6\text{ V}$ , D16 = 1	—	0	$\pm 4.0$	%
		$V_{\text{REF}} = 0.5\text{ V}$ , D16 = 1	—	0	$\pm 10$	%
Propagation Delay Time	$t_{\text{pd}}$	50% TO 90%:				
		PWM change to source on	600	750	1000	ns
		PWM change to source off	50	150	350	ns
		PWM change to sink on	600	750	1000	ns
		PWM change to sink off	50	150	350	ns
Crossover Delay Time	$t_{\text{COD}}$	SR enabled	300	600	1000	ns
Thermal Shutdown Temperature	$T_J$		—	165	—	$^\circ\text{C}$
Thermal Shutdown Hysteresis	$\Delta T_J$		—	15	—	$^\circ\text{C}$
UVLO Enable Threshold	$V_{\text{UVLO}}$	Increasing $V_{\text{DD}}$	3.9	4.2	4.45	V
UVLO Hysteresis	$\Delta V_{\text{UVLO}}$		0.05	0.10	—	V
Logic Supply Current	$I_{\text{DD}}$	$f_{\text{PWM}} < 50\text{ kHz}$	—	—	10	mA
		Outputs off	—	—	8.0	mA
		Idle mode (D18 = 1, D19 = 0)	—	—	1.5	mA
		Sleep mode (inputs below 0.5 V)	—	—	100	$\mu\text{A}$

NOTES: 1. Typical Data is for design information only.

2. Negative current is defined as coming out of (sourcing) the specified device terminal.

3.  $E_G = [(V_{\text{REF}}/\text{Range}) - V_S]/(V_{\text{REF}}/\text{Range})$ .

**FUNCTIONAL DESCRIPTION**

**Serial Interface.** The A3974SED is controlled via a 3-wire (clock, data, strobe) serial port. The programmable functions allow maximum flexibility in configuring the PWM to the motor drive requirements. The serial data is written as two 20-bit words: 1 bit to select the word and 19 bits of data. The data is clocked in starting with D19.

**Word 0 Bit Assignments**

Select Word 0 (D18 = 0)	
Bit	Function
D0	Bridge 1 blank time LSB
D1	Bridge 1 blank time MSB
D2	Bridge 1 off-time LSB
D3	Bridge 1 off-time bit 1
D4	Bridge 1 off-time bit 2
D5	Bridge 1 off-time bit 3
D6	Bridge 1 off-time MSB
D7	Bridge 1 fast-decay time bit LSB
D8	Bridge 1 fast-decay time bit 1
D9	Bridge 1 fast-decay time bit 2
D10	Bridge 1 fast-decay time MSB
D11	Bridge 1 sync. rect. control
D12	Bridge 1 sync. rect. control
D13	Bridge 1 external PWM mode
D14	Bridge 1 enable
D15	Bridge 1 phase
D16	Bridge 1 reference range select
D17	Bridge 1 internal PWM mode
D18	Word select = 0
D19	Test mode

**D0 – D1 Blank Time.** The current-sense comparator is blanked when any output driver is switched on, according to the table below.  $f_{osc}$  is the oscillator input frequency.

D1	D0	Blank Time
0	0	$4/f_{osc}$
0	1	$6/f_{osc}$
1	0	$12/f_{osc}$
1	1	$24/f_{osc}$

**D2 – D6 Fixed Off Time.** This five-bit word sets the fixed off-time for the internal PWM control circuitry. The off-time is defined by

$$t_{off} = (8 [1 + N]/f_{osc}) - 1/f_{osc}$$

where  $N = 0 \dots 31$

For example, with an oscillator frequency of 4 MHz, the fixed off-time will be adjustable from 1.75  $\mu s$  to 63.75  $\mu s$  in increments of 2  $\mu s$ .

**D7 – D10 Fast Decay Time.** This four-bit word sets the fast-decay portion of the fixed off-time for the internal PWM control circuitry. This will only have impact if mixed-decay mode is selected (via bit D17). For  $t_{fd} > t_{off}$ , the device will effectively operate in fast-decay mode. The fast-decay portion is defined by

$$t_{fd} = (8[1 + N]/f_{osc}) - 1/f_{osc}$$

where  $N = 0 \dots 15$

For example, with an oscillator frequency of 4 MHz, the fast-decay time will be adjustable from 1.75  $\mu s$  to 31.75  $\mu s$  in increments of 2  $\mu s$ .

**D11 – D12 Synchronous Rectification.**

D12	D11	Synchronous Rectifier
0	0	Disabled
0	1	Low side only
1	0	Active
1	1	Passive

The different modes of operation are described in the synchronous rectification section of the functional description.

**D13 External PWM Decay Mode.** This bit determines the current-decay mode when using ENABLE chopping for external PWM current control.

D13	Mode
0	Fast
1	Slow

continued next page ...

## FUNCTIONAL DESCRIPTION (continued)

**D14 Enable Logic.** This bit, in conjunction with ENABLE, determines if the output drivers are in the chopped or on state.

ENABLE1	D14	Mode
0	0	Chopped
1	0	On
0	1	On
1	1	Chopped

**D15 Phase Logic.** This bit determines if the device is operating in the forward or reverse state.

D15	State	OUT <sub>A</sub>	OUT <sub>B</sub>
0	Reverse	L	H
1	Forward	H	L

**D16 G<sub>m</sub> Range Select.** This bit determines if V<sub>REF</sub> is divided by 5 or 10.

D16	Divider
0	÷10
1	÷5

**D17 Bridge 2 Mode.** This bit determines slow or mixed decay for internal current-control operation.

D17	Decay Mode
0	Mixed
1	Slow

**D19 Test Mode.** This bit is reserved for testing and should never be changed by the user. Default (low) operates the device in normal mode.

## Word 1 Bit Assignments

Select Word 1 (D18 = 1)	
Bit	Function
D0	Bridge 2 blank time LSB
D1	Bridge 2 blank time MSB
D2	Bridge 2 off-time LSB
D3	Bridge 2 off-time bit 1
D4	Bridge 2 off-time bit 2
D5	Bridge 2 off-time bit 3
D6	Bridge 2 off-time MSB
D7	Bridge 2 fast-decay time bit LSB
D8	Bridge 2 fast-decay time bit 1
D9	Bridge 2 fast-decay time bit 2
D10	Bridge 2 fast-decay time bit MSB
D11	Bridge 2 sync. rect. control
D12	Bridge 2 sync. rect. control
D13	Bridge 2 external PWM mode
D14	Bridge 2 enable
D15	Bridge 2 phase
D16	Bridge 2 reference range select
D17	Bridge 2 internal PWM mode
D18	Word select = 1
D19	Idle mode

**D0 - D17.** Identical definitions as Word 0, with Word 1 selected. Data is written to Full Bridge 2.

**D19 Idle Mode.** The device can be placed in a low-power “idle” mode by writing a “0” to D19. The outputs will be disabled, the charge pump will be turned off, and the device will draw a lower load supply current. The undervoltage monitor circuit will remain active. D19 should be programmed high for 1 ms before attempting to enable any output driver.

continued next page ...



## FUNCTIONAL DESCRIPTION (continued)

**V<sub>REG</sub>.** This internally generated supply voltage is used to operate the sink-side DMOS outputs. V<sub>REG</sub> is internally monitored and in the case of a fault condition, the outputs of the device are disabled. The V<sub>REG</sub> terminal should be decoupled with a 0.22 μF capacitor to ground.

**Charge Pump.** The charge pump is used to generate a supply voltage greater than V<sub>BB</sub> to drive the source-side DMOS gates. A 0.22 μF ceramic capacitor should be connected between CP1 and CP2 for pumping purposes. A 0.22 μF ceramic capacitor should be connected between V<sub>CP</sub> and V<sub>BB</sub> to act as a reservoir to run the high-side DMOS devices. The CP voltage is internally monitored and in the case of a fault condition, the outputs of the device are disabled.

**Shutdown.** In the event of a fault due to excessive junction temperature, or low voltage on CP or V<sub>REG</sub>, the outputs of the device are disabled until the fault condition is removed. At power up, or in the event of low V<sub>DD</sub>, the UVLO circuit disables the drivers and resets the data in the serial port to all zeros.

**Current Regulation.** Load current is regulated by an internal fixed off-time PWM control circuit. When the outputs of the DMOS H-bridge are turned on, the current increases in the motor winding until it reaches a trip value determined by the external sense resistor (R<sub>S</sub>), the applied analog reference voltage (V<sub>REF</sub>), and serial data bit D16:

$$\text{When D16} = 0 \dots\dots\dots I_{\text{TRIP}} = V_{\text{REF}}/10R_{\text{S}}$$

$$\text{When D16} = 1 \dots\dots\dots I_{\text{TRIP}} = V_{\text{REF}}/5R_{\text{S}}$$

At the trip point, the sense comparator resets the source-enable latch, turning off the source driver (except in the case of low-side only mode where the sink driver is turned off). The load inductance then causes the current to recirculate for the serial-port programmed fixed off-time period. The current path during recirculation is determined by the configuration of slow/mixed-decay mode (D17) and the synchronous rectification control bits (D11 and D12).

**Sleep Mode.** The input terminal SLEEP is dedicated to putting the device into a minimum current draw mode. When asserted

low, the serial port will be reset to all zeros and all circuits will be disabled.

**PWM Timer Function.** The PWM timer is programmable via the serial port (bits D2 – D10) to provide fixed off-time PWM signals to the control circuitry. In mixed current-decay mode, the first portion of the off time operates in fast decay, until the fast-decay time count is reached (serial bits D7 – D10), followed by slow decay for the rest of the off-time period (bits D2 – D6). If the fast-decay time is set longer than the off-time, the device effectively operates in fast-decay mode. Bit D17 selects mixed or slow decay.

**Synchronous Rectification.** When a PWM off cycle is triggered, either by an ENABLE chop command or internal fixed off-time cycle, load current will recirculate according to the decay mode selected by the control logic. After a short crossover delay, the A3974 synchronous rectification feature will turn on the appropriate MOSFET (or pair of MOSFETs for the mixed decay portion of the off-time) during the current decay and effectively short out the body diodes with the low I<sub>DS(on)</sub> driver. This will lower power dissipation significantly and can eliminate the need for external Schottky diodes.

Synchronous rectification can be configured in active mode, passive mode, low side only, or disabled via the serial port (bits D11 and D12). The active mode prevents reversal of load current by turning off synchronous rectification when a zero current level is detected. Passive mode will allow reversal of current but will turn off the synchronous rectifier circuit if the load current inversion ramps up to the current limit set by V<sub>REF</sub>/10R<sub>S</sub> (when D16 = 0) or V<sub>REF</sub>/5R<sub>S</sub> (when D16 = 1).

Low side only mode will switch the low-side MOSFETs on during the off time to short out the current path through the MOSFET body diode. With this setting, the high-side MOSFETs will not synchronously rectify so four external diodes from output to supply are recommended. This mode is intended for use with high-power applications where it is desired to save the expense of two external diodes per bridge. In this mode, the sink-side MOSFETs are chopped during the PWM off time. In all other cases, the source-side MOSFETs are chopped in response to a PWM OFF command.

APPLICATIONS INFORMATION

**Current Sensing.** To minimize inaccuracies in sensing the  $I_{TRIP}$  current level caused by ground-trace IR drops, the sense resistor should have an independent ground return to a ground terminal of the device. For low-value sense resistors, the IR drops in the PCB sense traces of the resistor can be significant and should be taken into account. The use of sockets should be avoided as they can introduce variation in  $R_S$  due to their contact resistance.

The maximum value of  $R_S$  is given as  $R_S = 0.5/I_{TRIPMAX}$ .

**Braking.** The braking function is implemented by driving the device in slow-decay mode via serial port bit D13, enabling synchronous rectification via bits D11 and D12, and applying an enable chop command with the combination of D14 and the ENABLE input terminal. Because it is possible to drive current in both directions through the DMOS switches, this configuration effectively shorts out the motor-generated BEMF as long as the ENABLE chop mode is asserted. It is important to note that the internal PWM current-control circuit will not limit the current when braking, because the current does not flow through the sense resistor. The maximum brake current can be approximated by  $V_{BEMF}/R_L$ . Care should be taken to ensure that the maximum ratings of the device are not exceeded in worst-case braking situations of high speed and high inertial loads.

**Thermal protection.** Circuitry turns off all drivers when the junction temperature reaches 165°C typically. It is intended only to protect the device from failures due to excessive junction temperatures and should not imply that output short circuits are permitted. Thermal shutdown has a hysteresis of approximately 15°C.

**Layout.** The printed wiring board should use a heavy ground plane. For optimum electrical and thermal performance, the driver should be soldered directly onto the board. The ground side of  $R_S$  should have an individual path to a ground terminal of the device. This path should be as short as is possible physically and should not have any other components connected to it. The load supply terminal,  $V_{BB}$ , should be decoupled with an electrolytic capacitor (>47 µF is recommended) placed as close to the device as is possible.

**Serial Port Write Timing Operation.** Data is clocked into shift register on the rising edge of CLOCK signal. Normally, STROBE will be held high, and only will be brought low to initiate a write cycle. Refer to diagram below and specification table for timing requirements.

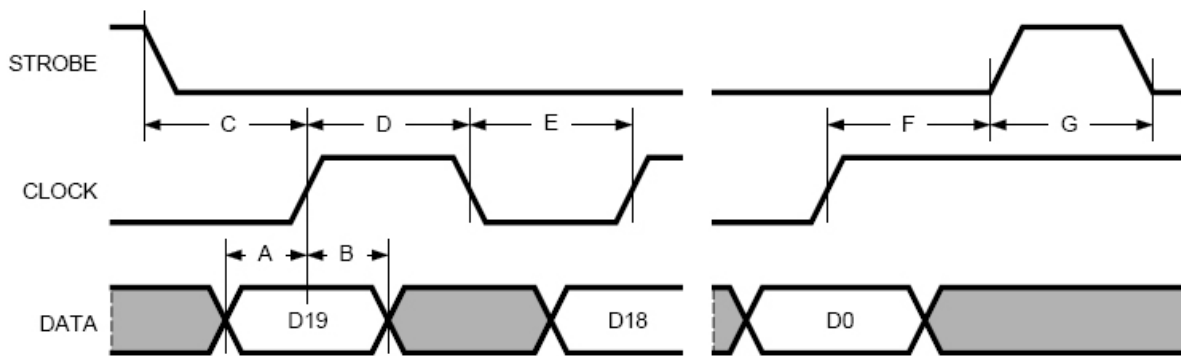

Dwg. WP-038

A. Minimum Data Setup Time .....	15 ns
B. Minimum Data Hold Time.....	10 ns
C. Minimum Setup Strobe to Clock Rising Edge .....	50 ns
D. Minimum Clock High Pulse Width .....	50 ns
E. Minimum Clock Low Pulse Width .....	50 ns
F. Minimum Setup Clock Rising Edge to Strobe .....	50 ns
G. Minimum Strobe Pulse Width .....	50 ns

**Terminal List**

<b>Terminal Name</b>	<b>Terminal Description</b>	<b>Terminal Number</b>
GND	Power and logic ground terminals	1, 2
SENSE <sub>1</sub>	Sense resistor terminal for bridge 1	3
NC	No (internal) connection	4, 5
OUT <sub>1A</sub>	DMOS H-bridge 1 – output A	6
NC	No (internal) connection	7
STROBE	Logic input for serial Interface	8
CLOCK	Logic input for serial Interface	9
DATA	Logic input for serial Interface	10
GND	Power and logic ground terminals	11, 12, 13
REF <sub>1</sub>	G <sub>m</sub> reference input voltage – bridge 1	14
REF <sub>2</sub>	G <sub>m</sub> reference input voltage – bridge 2	15
LOGIC SUPPLY	V <sub>DD</sub> , the low voltage (typically 5 V) supply	16
NC	No (internal) connection	17
OUT <sub>2A</sub>	DMOS H-bridge 2 – output A	18
NC	No (internal) connection	19, 20
SENSE <sub>2</sub>	Sense resistor pin for bridge 2	21
GND	Power and logic ground terminals	22, 23, 24
LOAD SUPPLY <sub>2</sub>	V <sub>BB2</sub> , the high current, 20 V to 50 V, supply for bridge 2	25
ENABLE <sub>2</sub>	Logic input for bridge 2 – enable control	26
NC	No (internal) connection	27
OUT <sub>2B</sub>	DMOS H-bridge 2 – output B	28
NC	No (internal) connection	29
V <sub>REG</sub>	Regulator decoupling capacitor (typ. 0.22 μF)	30
SLEEP	Logic input for SLEEP mode	31
OSC	Logic-level oscillator (square wave) input	32
GND	Power and logic ground terminals	33, 34, 35
CP	Reservoir capacitor (typically 0.22 μF)	36
CP1 & CP2	The charge pump capacitor (typically 0.22 μF)	37 & 38
NC	No (internal) connection	39
OUT <sub>1B</sub>	DMOS H-bridge 1 – output B	40
NC	No (internal) connection	41
ENABLE <sub>1</sub>	Logic input for bridge 1 – enable control	42
LOAD SUPPLY <sub>1</sub>	V <sub>BB1</sub> , the high current, 20 V to 50 V, supply for bridge 1	43
GND	Power and logic ground terminals	44

Package EB, 44-pin PLCC

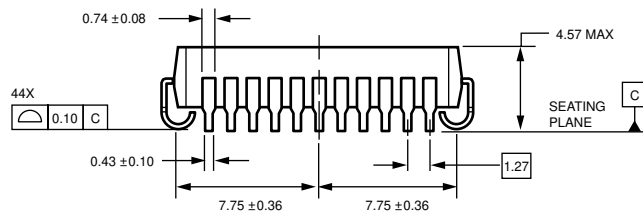
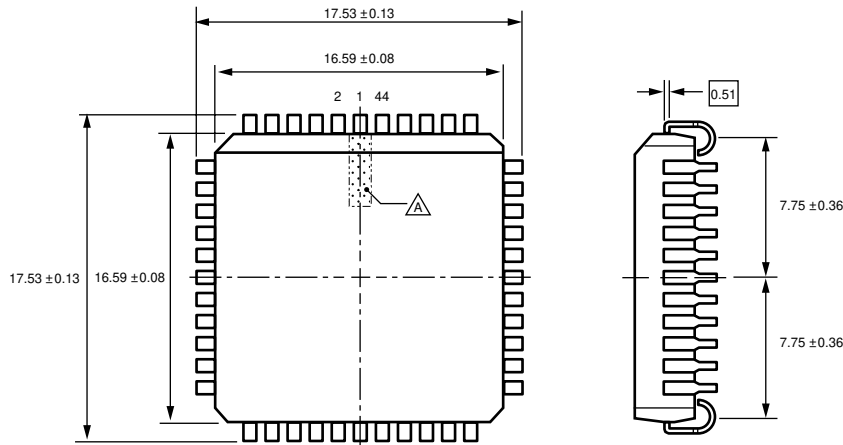

For Reference Only  
 (reference JEDEC MS-018 AC)  
 Dimensions in millimeters  
 Internally fused pins 44, 1 and 2; 11-13; 22-24; and 33-35  
 Dimensions exclusive of mold flash, gate burrs, and dambar protrusions  
 Exact case and lead configuration at supplier discretion within limits shown  
 ▲ Terminal #1 mark area

Copyright ©2001-2008, Allegro MicroSystems, Inc.

The products described here are manufactured under one or more U.S. patents or U.S. patents pending.

Allegro MicroSystems, Inc. reserves the right to make, from time to time, such departures from the detail specifications as may be required to permit improvements in the performance, reliability, or manufacturability of its products. Before placing an order, the user is cautioned to verify that the information being relied upon is current.

Allegro's products are not to be used in life support devices or systems, if a failure of an Allegro product can reasonably be expected to cause the failure of that life support device or system, or to affect the safety or effectiveness of that device or system.

The information included herein is believed to be accurate and reliable. However, Allegro MicroSystems, Inc. assumes no responsibility for its use; nor for any infringement of patents or other rights of third parties which may result from its use.

For the latest version of this document, visit our website:

[www.allegromicro.com](http://www.allegromicro.com)

