

LOC		DIST		REVISIONS			
CM	0	REV	DATE	BY	CHK	APPV	
M	REVISED PER ECO-12-016930		05OCT12	KH	SM		

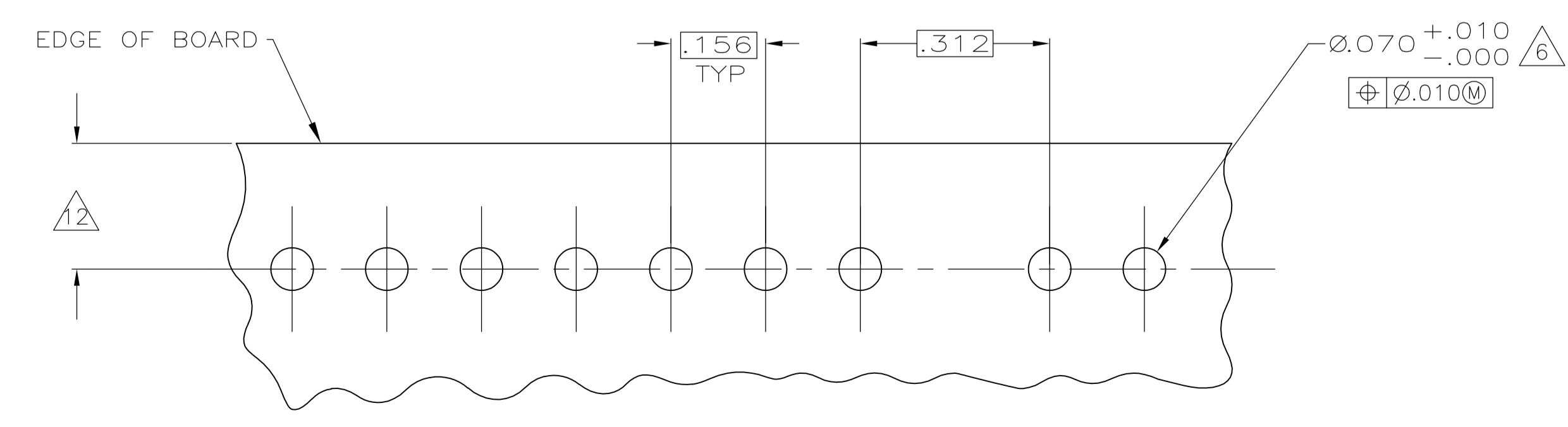
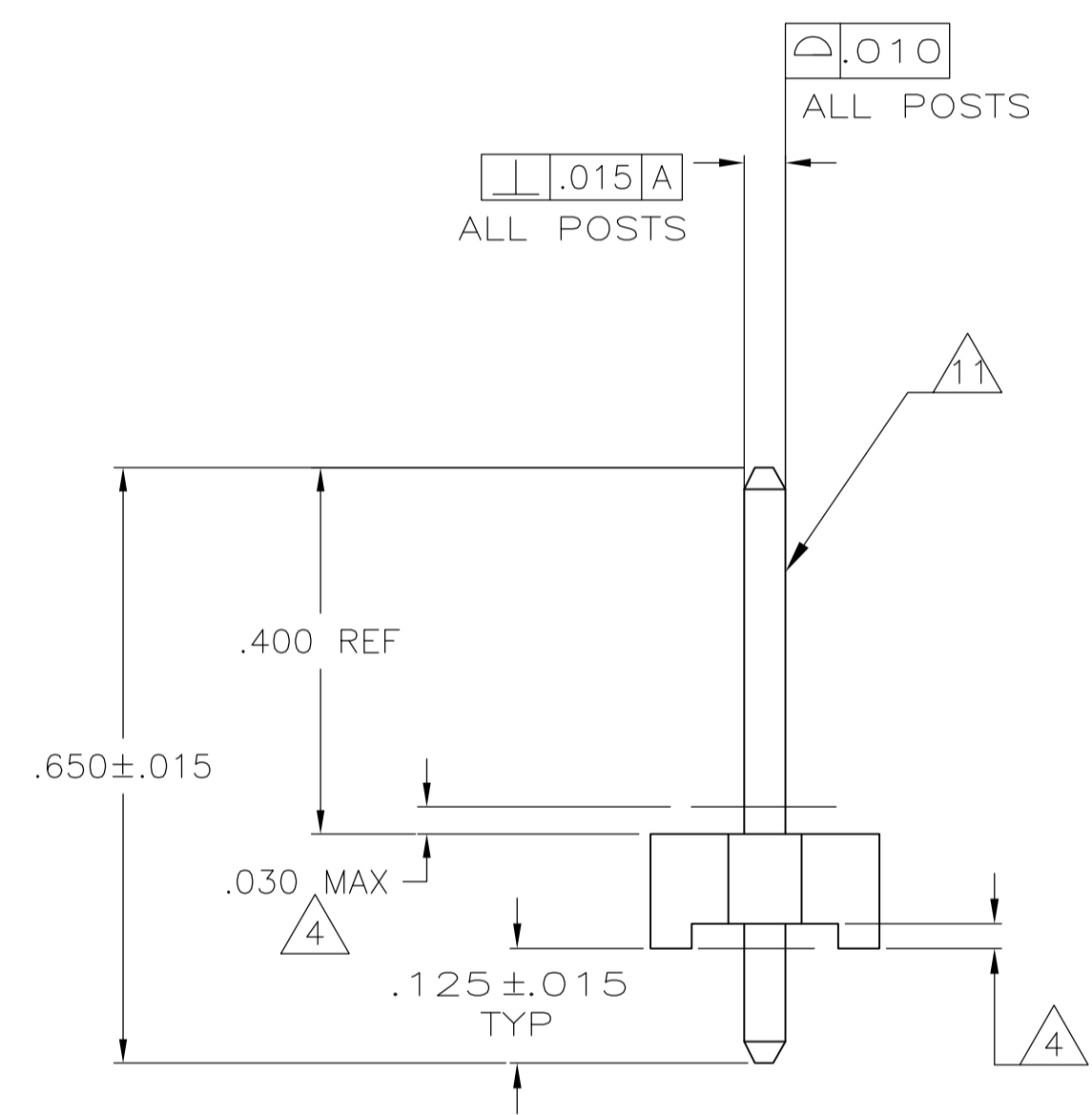
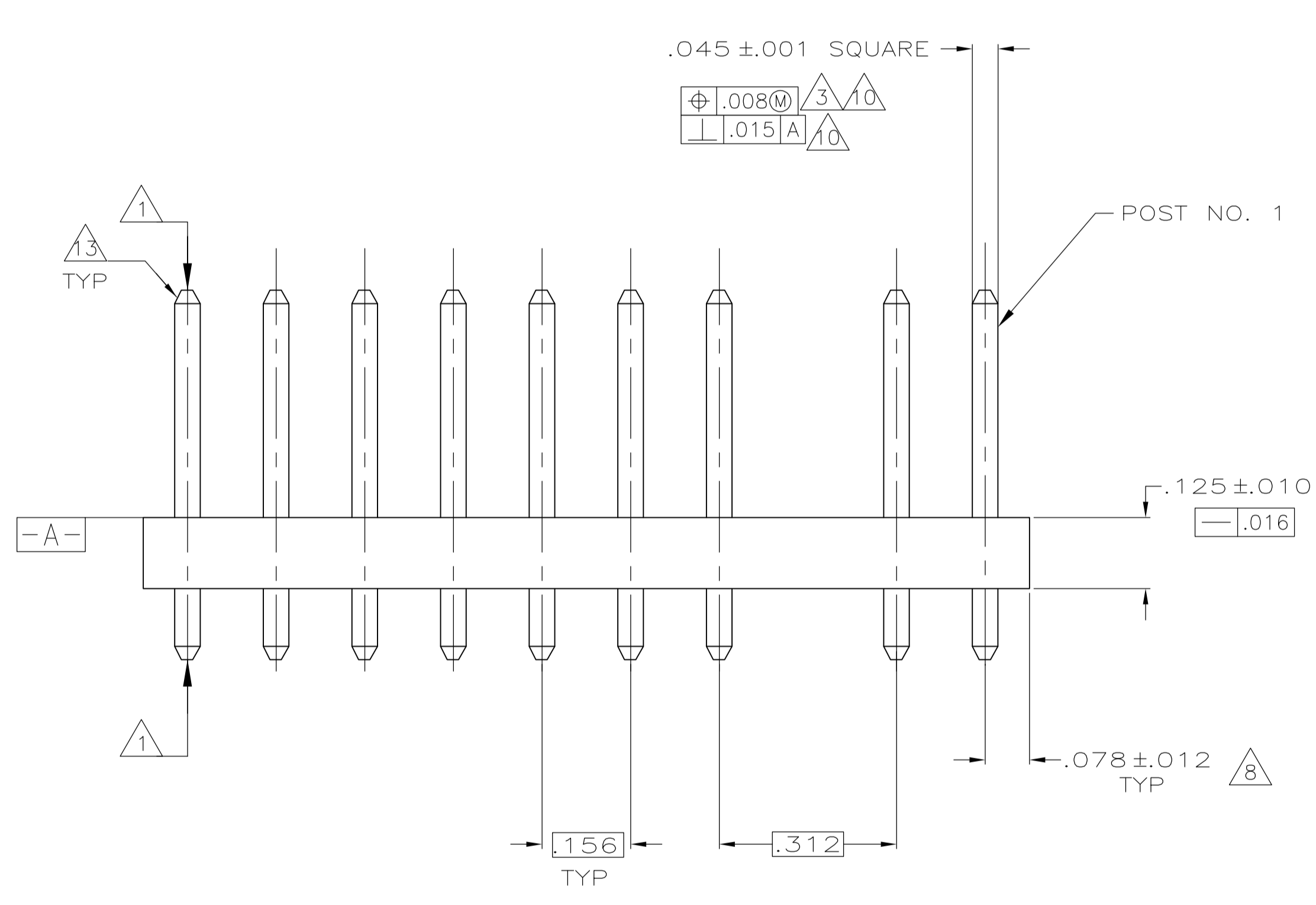
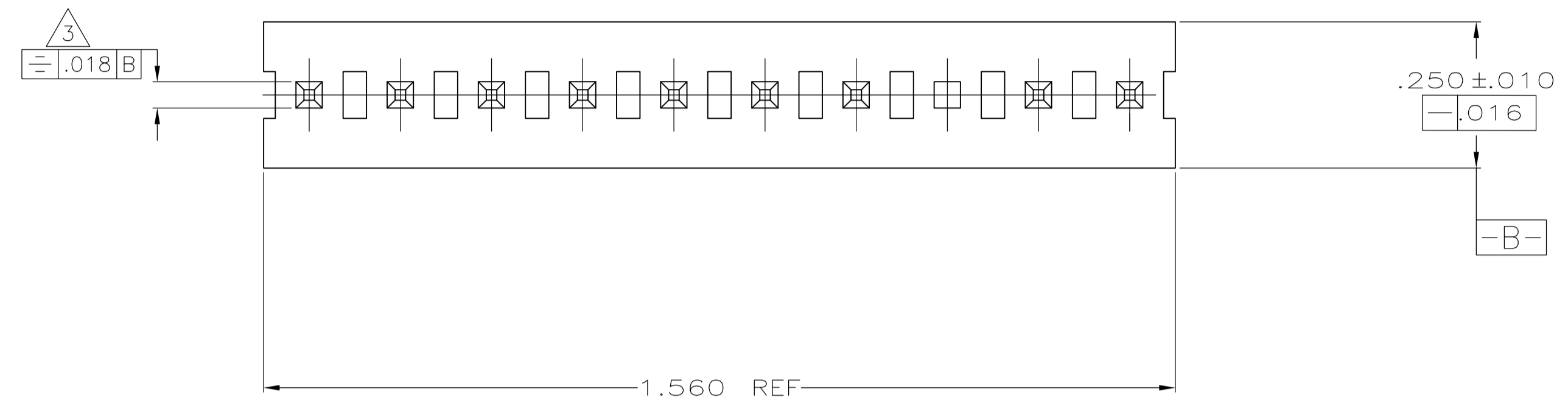

IN	MM	IN	MM
.063	1.60	-	-
.060	1.52	-	-
.045	1.14	1.560	39.62
.030	0.76	.700	17.78
.018	0.46	.450	11.43
.016	0.41	.312	7.92
.015	0.38	.250	6.35
.012	0.30	.156	3.96
.010	0.25	.140	3.56
.008	0.20	.125	3.18
.005	0.13	.078	1.98
.003	0.08	.070	1.78
.001	0.03	.065	1.65
IN	MM	IN	MM

CONVERSION TABLE

RECOMMENDED MOUNTING HOLE PATTERN FOR .063 THICK P.C. BOARD

- 1 POST TO WITHSTAND 13 NEWTONS (3LBS.) MIN. AXIAL FORCE IN BOTH DIRECTIONS SHOWN WITHOUT DISLODGING.
- 2 TOLERANCES APPLY TO SOLDER SIDE OF BOARD.
- 3 MEASURED AT SURFACE -A-
- 4 PLASTIC FLASH PERMITTED IN THIS AREA.
- 5 PARTS COMPLY WITH AMP SOLDERABILITY SPEC. NO. 109-11-2.
- 6 ONE HOLE MAY BE UNDERSIZED (.065/.060 DIA.) FOR ASSEMBLY RETENTION DURING WAVE SOLDERING.
- 7 MATERIAL: HEADER-THERMOPLASTIC POLYESTER  
GLASS-FILLED 94V-0(NATURAL)  
POST-COPPER ALLOY (TIN PLATED)
- 8 COORDINATE DIMENSION APPLIES FROM CENTER OF ACTUAL FEATURE.
- 9 PLASTIC BURRS CAUSED BY CUT-OFF TOOLING ARE PERMITTED WITHIN THE MAXIMUM TOLERANCE ENVELOPE.
- 10 POST TO BE MEASURED WHEN STRIP IS HELD FLAT.
- 11 POST MUST WITHSTAND TWO 90° BENDS AGAINST EXTRUSION WITHOUT BREAKING.
- 12 DIMENSION SHOULD BE .140 MIN WHEN MATING WITH A MTA 156 CONNECTOR ASSEMBLY OR A SL-156 CONNECTOR ASSEMBLY.
- 13 PIN BURR OF .005 MAX. VERTICAL AND .003 MAX. HORIZONTAL PERMITTED AT POST TIPS ON BOTH ENDS.

643886-2 SHOWN

POST NUMBER	PART NUMBER
3 & 6	643886-5
5	643886-4
4	643886-3
3	643886-2
2	643886-1
POST NUMBER OMITTED	PART NUMBER

THIS DRAWING IS A CONTROLLED DOCUMENT.

DIMENSIONS: INCHES	TOLERANCES UNLESS OTHERWISE SPECIFIED:	DIN K. WHITAKER 18APR2006	CHK D. ROSSI 18APR2006	NAME
0 PLC ± -	1 PLC ± -	2 PLC ± -	3 PLC ± .005	4 PLC ± -
ANGLES ± -				
MATERIAL	FINISH	WEIGHT	SIZE	CAGE CODE
			A1	00779
CUSTOMER DRAWING		SCALE	SHEET	REV
		5:1	1 of 1	M

STE TE Connectivity

MTA-156 HEADER ASSEMBLY, PLAIN, STRAIGHT, .045 SQUARE POST, TIN PLATED, 10 POSITION, OMITTED POST

643886