

# 常州市万泰电器有限公司 Hybrid Linear Actuators

## 39BYGL

### SERIES HYBRID STEPPING MOTOR(混合式步进电机)

#### General Specifications(详细说明):

Step Accuracy..... ± 5%  
 Temperature Rise.....80°C Max  
 Ambient Temperature Range.....-20°C~+50°C  
 Insulation Resistance.....100MΩ Min.500VC DC

电机型号 Model	步长 Step distance mm/step	机身長 Motor Length L(mm)	相电压 Rate Voltage (V)	相电流 Rate Current (A)	相电阻 Phase Resistance (Ω)	相电感 Phase Inductance (mH)	静转矩 Holding Torque (N.m)	引线数 Lead Wire (NO.)	定位力矩 Detent Torque (kg.cm)	转动惯量 Rotor Inertia (kg.cm <sup>2</sup> )	重量 Motor Weight (kg)
39BYGL215A	0.01	34	12	0.4	30	42	0.21	4	0.12	0.02	0.18

Dielectric Strength.....500V AC 1S

#### Electrical Specifications(技术数据):

\*以上仅为代表产品，特殊产品可根据客户要求制作

#### Mechanical Dimensions(外型图)

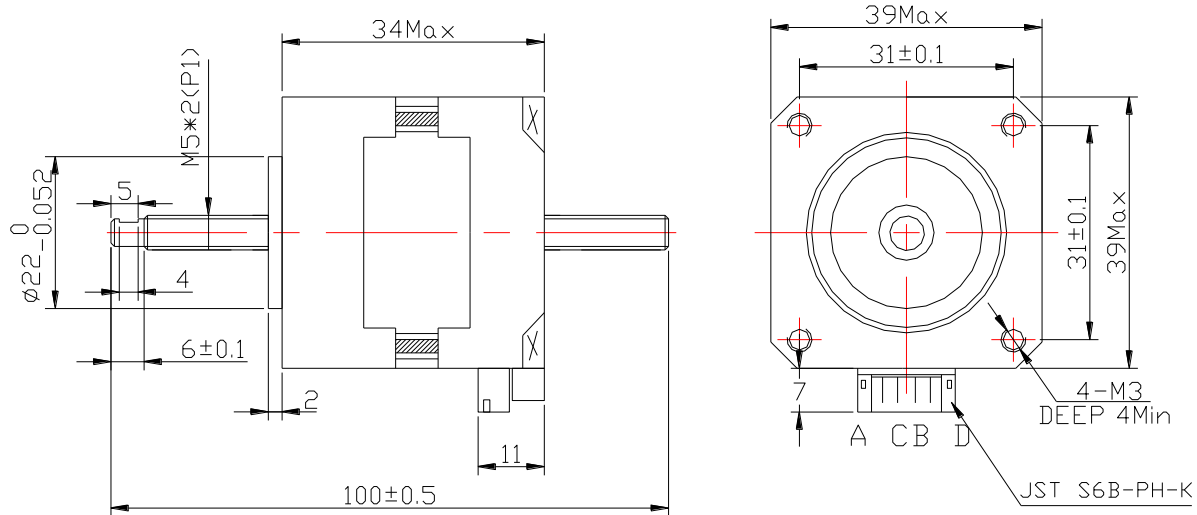

#### Wiring diagram(接线图):

