

THIS DRAWING IS UNPUBLISHED. RELEASED FOR PUBLICATION
 © COPYRIGHT - By - ALL RIGHTS RESERVED.

LOC	DIST	REVISIONS					
AF	50	P	LTR	DESCRIPTION	DATE	DWN	APVD
			C	REVISED PER ECR-13-011489	29NOV2013	KH	PD

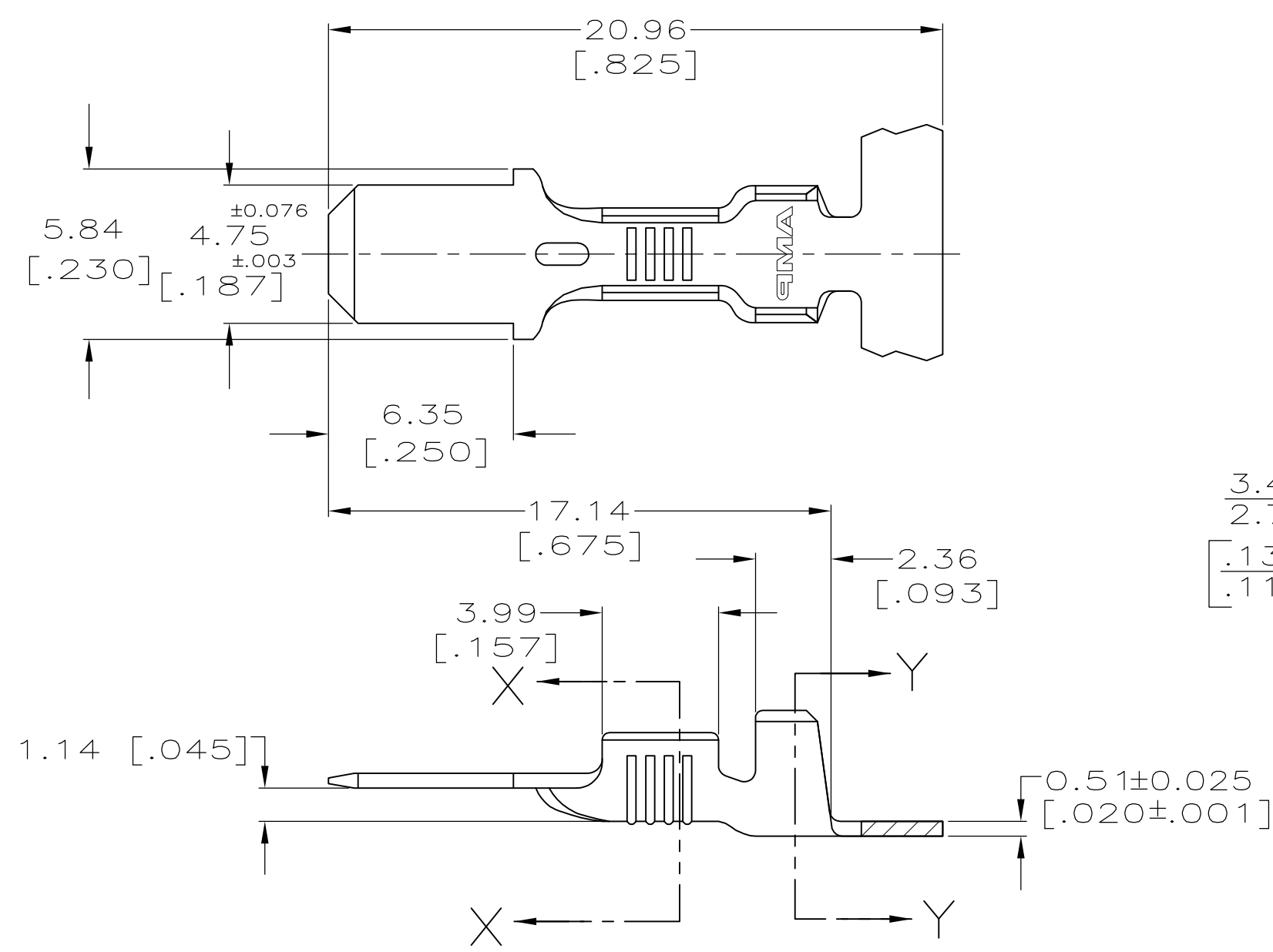

- 1 CONTINUOUS STRIP ON REELS.
- 2 FEED TO BE 11.18±0.076 [.440±.003].

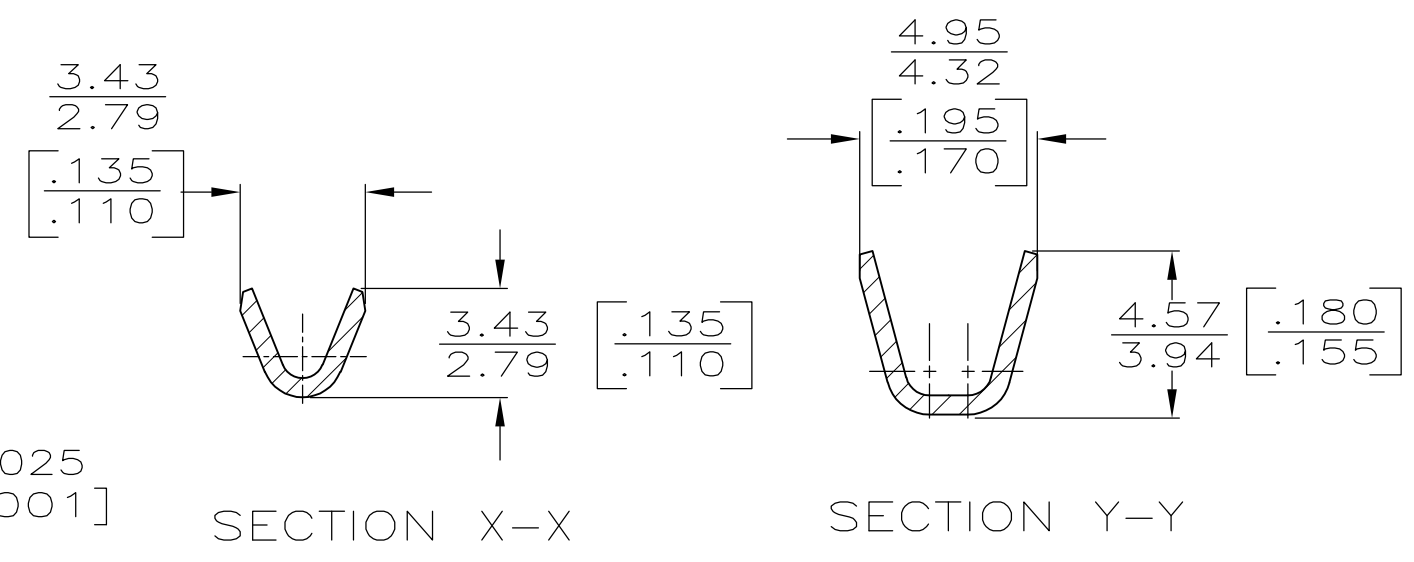

1.52-3.05 DIA [.060-.120] DIA	[#22-#18] AWG	63857-1
INSULATION RANGE	WIRE SIZE	PART NO

0	3.30 [.130]	5.59 [.220]	F	2.29 [.090]	1.65 [.065] [#18]	1.52 [.060] [#20]	1.45 [.057] [#22]
TYPE	WIDTH	±0.38 [±.015] STRIP LENGTH	TYPE	WIDTH	±0.051 [.002] HEIGHT	WIRE	
INSUL BARREL CRIMP			WIRE BARREL CRIMP				

THIS DRAWING IS A CONTROLLED DOCUMENT.

DIMENSIONS: mm [INCHES]

TOLERANCES UNLESS OTHERWISE SPECIFIED:

0 PLC ± -
 1 PLC ± -
 2 PLC ± 0.25 [.010]
 3 PLC ± -
 4 PLC ± -
 ANGLES ± -

MATERIAL: BRASS
 FINISH: TIN

DWN	JR RUTH	5/9/95	TE Connectivity NAME: TAB, FASTON, 4.75 [.187] SERIES
CHK	MS FEHER	5/9/95	
APVD	P DESANTIS	5/9/95	
PRODUCT SPEC			
APPLICATION SPEC			RESTRICTED TO
WEIGHT	-		SIZE: A3
CUSTOMER DRAWING		SCALE: 5:1	CAGE CODE: 00779
		SHEET: 1 OF 1	DRAWING NO: C-63857
		REV: C	