

NEVO+1200 Series

USER MANUAL



1200W

Powerful

6" x 6" x 1.61"

Small

1.2kg

Light

The Ultimate 1200 Watt Configurable Solution

The NEVO+1200 series user manual has been prepared by the Vox Power design team to assist qualified engineers in correctly implementing the product and to achieve the best reliability and performance possible.

All specifications are believed to be correct at time of publishing. Vox Power Ltd reserves the right to make changes to any of its products and to change or improve any part of the specification, electrical or mechanical design or manufacturing process without notice. Vox Power Ltd does not assume any liability arising out of the use or application of any of its products and of any information to the maximum extent permitted by law. No license, express or implied, by estoppel or otherwise, to any intellectual property rights is granted by this document or by any products of Vox Power Ltd. VOX POWER LTD DISCLAIMS ALL WARRANTIES AND REPRESENTATIONS OF ANY KIND WHETHER EXPRESS OR IMPLIED, INCLUDING, BUT NOT LIMITED TO, IMPLIED WARRANTIES OF SUITABILITY, FITNESS FOR PURPOSE, MERCHANTABILITY AND NON-INFRINGEMENT.

Please consult your local distributor or Vox Power directly to ensure that you have the latest revision before using the product and refer to the latest relevant user manual for further information relating to the use of the product. Vox Power Ltd products are not intended for use in connection with life support systems, human implantations, nuclear facilities or systems, aircraft, spacecraft, military or naval missile, ground support or control equipment used for the purpose of guidance navigation or direction of any aircraft, spacecraft or military or naval missile or any other application where product failure could lead to loss of life or catastrophic property damage. The user will hold Vox Power Ltd harmless from any loss, cost or damage resulting from its breach of these provisions.

NEVO+1200 Series Overview

The NEVO+1200 switch mode power supply series offers truly unrivalled power density, providing 1200W at 22W/in³ in a 6"x6"x1U package. It is the ultimate power solution for system designers as they address the demand for more power in less space. Providing multiple isolated outputs, the series carry full IEC60601 (NEVO+1200M) and IEC62368 & IEC60950 (NEVO+1200S) safety approvals. A standard NEVO+1200 product configuration consists of an input module together with up to eight fully isolated output modules. Single output modules have advanced remote voltage and current programming functionality as standard. While dual output modules allow for up to sixteen fully isolated outputs. The input module delivers up to 1200W of output power and has 8 slots, each capable of delivering up to 150W. Two 5V, 1A medically isolated bias supplies, an AC_OK signal and a global inhibit signal that can disable all outputs simultaneously are standard features of a NEVO configuration. An additional (always on) 5V, 0.5A bias supply is provided which enables a fully latched shutdown feature to be implemented on the primary power converter. In this mode both fans are off and the power consumption is below 5Watts (Typical Value of 3 Watts). Output modules are available in a range of output voltages and currents to suit all applications. Single output modules with voltage ranges from 1.5V to 60V, currents up to 25A and paralleling and series capability can result in a voltage range up to 480V and a maximum current of up to 200 Amps from a single NEVO+1200 configuration. Dual output modules have a voltage ranges from 1.5V to 15V and currents up to 5A with series capability. By selecting the correct output modules, a custom power solution can be configured in a few minutes. This fast custom solution offers industry leading power density and total system efficiencies of up to 89%. This flexibility ensures the NEVO+1200 series suits all types of applications including medical, industrial, lighting, aerospace, military and telecoms.

Contents

NEVO+1200 Series Overview.....	1
Contents	2
Part Numbers and Ordering Information.....	3
Installation Notes	4
Theory of Operation	6
Input Module Operation	7
Signalling	10
Single Output module operation	13
Advanced Single Output Module Features.....	16
Series Connected Outputs	19
Parallel Connected Outputs.....	20
Dual Output module operation.....	24
Audible Noise.....	26
Mechanical Dimensions and Mounting	28
Connectors	29
Configuring Your NEVO Product.....	30
Safety	38
EMC Compliance	39
Reliability.....	39

Part Numbers and Ordering Information

INPUT MODULES	
Input Module	Details
NEVO+1200S	1200 Watt input stage with ITE Approvals (UL/IEC60950 Edition 2 & UL/IEC62368 Edition 2)
NEVO+1200SL	900 Watt low audible noise input stage with ITE Approvals (UL/IEC60950 Edition 2 & UL/IEC62368 Edition 2)
NEVO+1200M	1200 Watt input stage with Medical Approvals (UL/IEC60601 Edition 3 + UL/IEC60601-1-2 Edition 4 EMC)
NEVO+1200ML	900 Watt low audible noise input stage with Medical Approvals (UL/IEC60601 Edition 3 + UL/IEC60601-1-2 Edition 4 EMC)

OUTPUT MODULES								
Module	Nominal Voltage	Rated Current	Rated Power	Adjustment Range	Load Regulation	Line Regulation	OVP	Slots
0	Unused slots							1
1	5V	25A	125W	1.5V-7.5V	±50mV	±0.1%Vnom	9V	1
2	12V	15A	150W	4.5V-15V	±100mV	±0.1%Vnom	18V	1
3	24V	7.5A	150W	9V-30V	±150mV	±0.1%Vnom	36V	1
4	48V	3.75A	150W	18V-58V	±300mV	±0.1%Vnom	66V	1
A2	12V	25A	300W	4.5V-15V	±100mV	±0.1%Vnom	18V	2
A3	24V	15A	300W	9V-30V	±150mV	±0.1%Vnom	36V	2
5	12V Dual OP	5A	75W x 2	3.3V-15V Each Ch	±50mV	±0.1%Vnom	22V	1
8	24V Dual OP	3.125A	75W x 2	24V Each Ch	±100mV	±0.1%Vnom	30V	1

PART NUMBERS AND ORDERING INFORMATION

Series Name - NEVO+1200 S L -

Product Type
M - Medical
S - Industrial

Fan
Blank = Standard,
L = Low Noise

Slot A - Output #

Slot B - Output #

Slot C - Output #

Slot D - Output #

1 1 2 2 3 3 4 4 - 0 0 0

Factory Configuration Number

USE '0' for unused slots. Blanking plates will be inserted at factory.

Slot H - Output #

Slot G - Output #

Slot F - Output #

Slot E - Output #

Industrial input module has ITE approvals (IEC60950 & IEC62368), Medical input module has medical approvals (IEC60601)
 Contact your Distributor or Vox Power for special configuration requirements. The factory may allocate a 3 digit suffix to identify such requirements.
 When ordering an input unit with no outputs inserted, use NEVO+1200M/ML or NEVO+1200S/SL.
 Example Part Numbers:
 NEVO+1200ML-11223344 = Low Noise, Medical, 900W, 5V@25A, 5V@25A, 12V@15A, 12V@15A, 24V@7.5A, 24V@7.5A, 48V@3.75A, 48V@3.75A
 NEVO+1200S-A2A31144 = Industrial, 1200W, 12V@25A, 24V@15A, 5V@25A, 5V@25A, 48V@3.75A, 48V@3.75A

Installation Notes

This NEVO+1200 series of configurable power supplies are intended for use within end customer applications which restrict access to un-authorized personnel. The instructions in this manual and all warning labels on the product must be adhered to carefully.

SAFETY

The NEVO+1200S and NEVO+1200M series are designed in accordance with the relevant safety requirements of IEC/EN/UL/CSA 62368-1, IEC/EN/UL/CSA 60950-1, IEC/EN/UL/CSA 60601-1, Low voltage Directive LVD 2014/35/EU and EMC directive EMC 2014/30/EU. All NEVO+1200 series power supplies must be installed correctly in a controlled environment which restricts access to any un-authorized personnel. Equipment and system manufacturers must protect service personnel against unintentional contact with the output terminals.

DE-RATING

Temperature - The input module and output module power must be de-rated by 2.5%/°C above 50°C.

Input Voltage -The input module power must be de-rated by 10W/Vrms below 120Vrms (1200W @ 120Vrms, 1000W @ 100Vrms, 900W @ 90Vrms)

Remember to take the appropriate de-rating into consideration before specifying any NEVO+1200 power supply for an application. If in any doubt please contact Vox Power directly or your local Vox Power representative.

HAZZARDS

If series and/or parallel combinations of outputs exceed safe voltage and/or energy levels, the final equipment manufacturer must provide the appropriate protection for both users and service personnel.

HEALTH AND SAFETY

To comply with section 6 of the health and safety at work act, a label that is clearly visible to service personnel must be placed on the final equipment. These labels warn that surfaces of the power supply may be hot and should not be touched when the product is operating.

FUSING

The power supply has internal single pole fusing in the L (Live) line.

Fuses are not replaceable. Damaged units should be returned to Vox Power for analysis and repair.

For Medical (60601-1) installations, the end application should provide an appropriately rated external fuse in the Neutral line.

DC operation is not covered by safety approvals. Contact Vox Power for details.

SERVICING

The power supply contains no user serviceable parts. Repairs must be carried out by authorised personnel only. Contact Vox Power for further information.

APPROVAL LIMITATIONS – NORTH AMERICA

When this product is used with 180VAC–253VAC mains where no neutral is present, connect the two live wires to L (Live) and N (Neutral) on the input connector.

COOLING

For proper cooling of the power supply, the air intake and outlet must not be impeded. Allow 50mm clearance at both ends and position cabling appropriately.

EARTH TERMINAL MARKING

To comply with the requirements of IEC/EN/UL/CSA 62368-1, IEC/EN/UL/CSA 60950-1 & IEC/EN/UL/CSA 60601-1, where the incoming wiring earth is intended for connection as the main protective earth conductor and where the terminals for such a connection is not supplied on a component or subassembly, the user shall add an appropriate label displaying a protective earth symbol in accordance with IEC60417-5019 (2006-08) directly adjacent to the terminal. The label should be durable and legible and should withstand the 15 second rub test as per UL60950-1 section 1.7.15.

WARRANTY

Contact your sales agent or Vox Power for product repairs. See Vox Power standard terms and conditions for warranty conditions. Vox Power products are not intended for use in connection with life support systems, human implantations, nuclear facilities or systems, aircraft, spacecraft, military or naval missile, ground support or control equipment used for the purpose of guidance navigation or direction of any aircraft, spacecraft or military or naval missile or any other application where product failure could lead to loss of life or catastrophic property damage. The user will hold Vox Power harmless from any loss, cost or damage resulting from its breach of these provisions.

PRODUCT LABELS

The external product label contains information relevant to the power system. The label contains input voltage, maximum input current, input frequency, maximum output power, fuse rating and type, serial number, approvals and product part number in format NEVO+1200X-YYYYYYYY-ZZZ.

NEVO OUTPUT MODULES

Each output module label contains information relevant to that particular output. The label contains voltage adjustment range, maximum output current, serial number, approvals and the part number in format OP X.

OTHER

- A label warning that external surfaces are hot during operation and that the unit should be allowed to cool down properly should be placed on the unit where such a label is clearly visible.
- The NEVO+1200 series is designed to comply with EMC standards but it does not imply that the end system will comply.
- To prolong the life of the unit use in dust free environment.
- Units can sometimes be damaged during transit. In the event of transit damage, DO NOT connect power to the unit. Contact your sales agent or Vox Power.
- Always use adequately sized cables and ensure good crimp connections. Use cable supports to minimise stress on connectors.
- Avoid excessive shock or vibration.

General installation parameters

- Equipment class I
- Installation category II
- Pollution degree 2
- Material group IIIb (Indoor use only)
- Flammability rating 94V-2
- IP rating IP10
- RoHS compliance 2011/65/EU

Theory of Operation

The diagram below outlines the topology and major internal components of a fully assembled NEVO+1200 configuration. Eight output slots are provided and can be populated by any combination of *output modules*. The remaining components in the block diagram are housed in the *input module*.

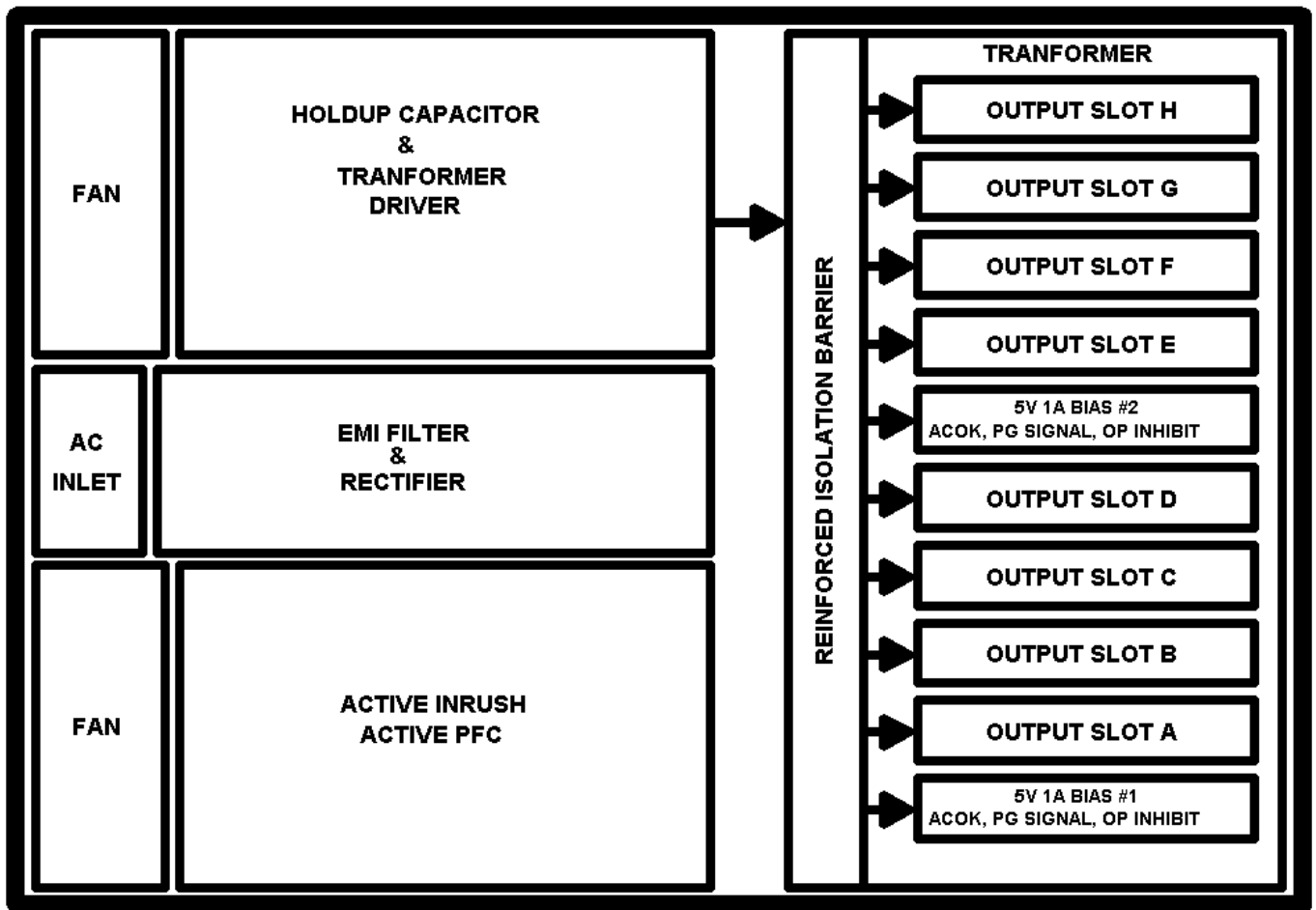

The *input module* is responsible for receiving the AC mains line voltage and converting it to an appropriate DC voltage whilst providing protection from AC line disturbances and preventing excessive EMI emissions and current harmonics. The integrated EMI filter attenuates high frequency current emissions to levels below EN55022 class B. It also provides single pole fusing in the live conductor and protection from line disturbances as outlined in EN61000.

Inrush current is controlled by a resistive element upon initial connection to the AC line. Once the internal capacitances have been charged, the resistive element is bypassed to reduce losses.

Active Power Factor Correction (PFC) is used to ensure an accurate input current waveform with extremely low harmonic content, exceeding the requirements of EN61000. This stage also provides active input current limiting which prevents overloading of the input stage while maintaining high power factor.

The output of the PFC stage charges the hold-up electrolytic capacitors which store enough energy to allow the NEVO+1200 configuration to continue operating during minor line disturbances. These are the only electrolytic capacitors in the NEVO+1200S/M power supplies. Long lifetime and high temperature capacitors are used which ensures extended lifetime and product reliability.

A highly efficient zero voltage switching circuit is used to drive the isolated transformer from the hold-up capacitors. The output modules connect to the transformer secondary and provide safe isolated power to a high performance synchronous rectifier power converter. This power converter is controlled using the latest analog control technology to produce superior output performance in a miniature size.

Input Module Operation

Startup & Shut Down

The NEVO input module operates from a universal input voltage range and starts automatically upon application of adequate AC mains voltage (>84Vrms). After a short delay, the global 5V bias supplies start and the ACOK signal goes high to indicate that the mains voltage is present and input stage is operating correctly. Once the ACOK signal is high, the output modules turn on and deliver power to the application loads. The power good signals will indicate that the output voltages are within specification. The diagram below shows the normal start up/shut down sequence and gives typical timings.

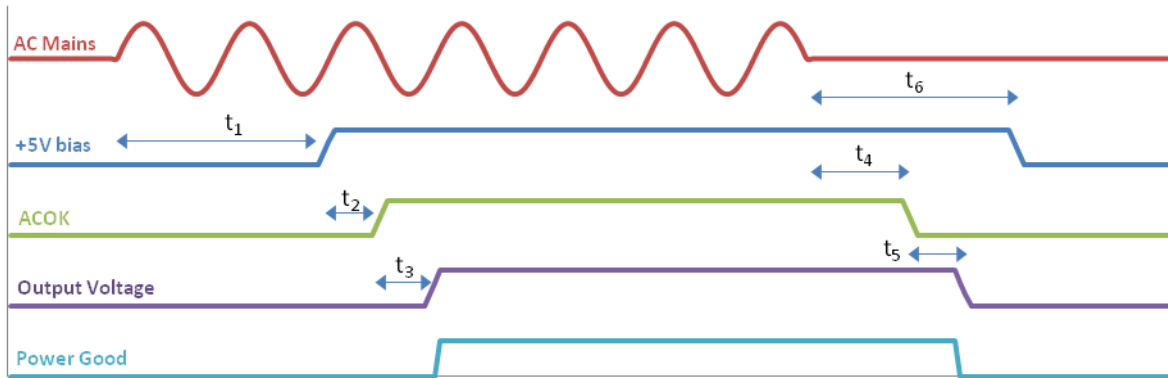

Typical timing values at 25°C: $t_1 \approx 2000$ ms, $t_2 \approx 50$ ms, $t_3 \approx 25$ ms, $t_4 \approx 15$ ms, $t_5 = 5$ ms (minimum), $t_6 \approx 100$ ms

When the AC mains voltage is removed, the internal hold-up capacitors will supply power to the load for typically 20 ms (t_4+t_5) at maximum power. The ACOK signal will go low at least 5ms before the output voltages fall below the power good threshold level. This allows the application to prepare for the impending loss of power. The 5V bias supply will remain on for typically 80ms, after the output modules have turned off.

Hold-up

For short line disturbances (<20ms), the output voltages will not be affected*. However, the ACOK signal may still go low to warn that there is an impending loss of output power. The ACOK signal will return to the high state once the unit has recovered from the disturbance.

*Outputs that are adjusted above the hold-up voltage as detailed in their respective datasheets, may experience a dip in voltage but never below the hold-up voltage specified.

Idle power/Standby Power Consumption

The idle power of the NEVO+1200 series PSU is extremely low when compared to similar configurable power supplies.

With the output modules enabled the unit typically only requires 46 W with no output load. To reduce the idle power further the outputs can be disabled using the global inhibit (GINH) pins. With the outputs disabled the unit typically requires less than 36 W. When the unit is in the latched off (SHUTDOWN) state, the idle power is less than 5W (Typical Value 3W)

Over Temperature Protection (OTP)

The input module is protected from excessive temperatures by means of various internal sensors. If temperature thresholds are exceeded the entire unit may latch off, with no ACOK warning. To re-enable the unit the AC mains must be disconnected for approximately 20seconds.

Over Power Protection (OPP)

The input module is protected from excessive power by means of a hiccup mode over power protection circuit. The threshold for the protection is approximately 120% of the rated power. If this threshold is exceeded the unit will shutdown for a short period before recovering automatically. If the overload remains this process will repeat indefinitely.

Power De-Rating

The NEVO+1200 series must always be operated within its stated operating limits. Equipment manufacturers and other users must take the appropriate de-rating into account when specifying a unit for the intended application. If in doubt contact your sales representative or Vox Power for assistance.

There are two main de-ratings for the NEVO+1200 series configurable power supplies i.e. temperature and input line voltage. Temperature de-ratings apply to both input and output modules, while line de-ratings apply only to the input module.

For input line voltage, S & M models have an input module power derating of 10W per volt below 120Vrms. For SL & ML models the derating is 7.5W per volt below 120Vrms.

For temperature, the de-rating for both input and output modules is 2.5% per degree Celsius above 50°C. This derating applies to maximum rated input and output power and maximum rated output current. All deratings are cumulative.

These de-ratings can be calculated using the following conditional equations;

Equation for line de-rating of input module only:

If $V_{in} < 120V$,
 $P_{out} = Prated - (10W * (120V - V_{in}))$

Otherwise,
 $P_{out} = Prated$

Equations for temperature de-rating

of the input and output modules:

If $temp > 50^{\circ}C$,

$P_{out} = Prated - [(Temp - 50^{\circ}C) * (0.025 * Prated)]$

Otherwise,
 $P_{out} = Prated$

$I_{out} = I_{rated} - [(Temp - 50^{\circ}C) * (0.025 * I_{rated})]$

Otherwise,
 $I_{out} = I_{rated}$

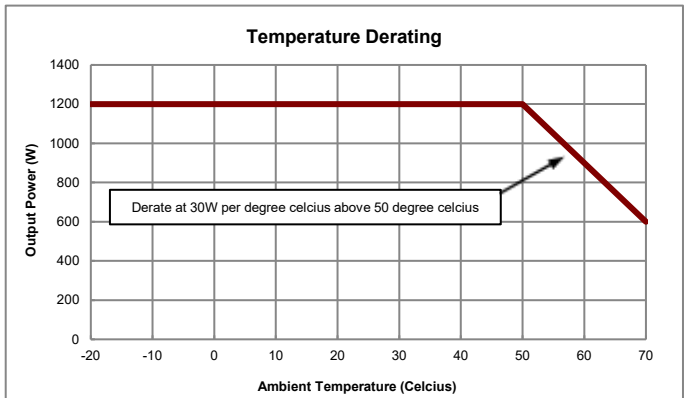
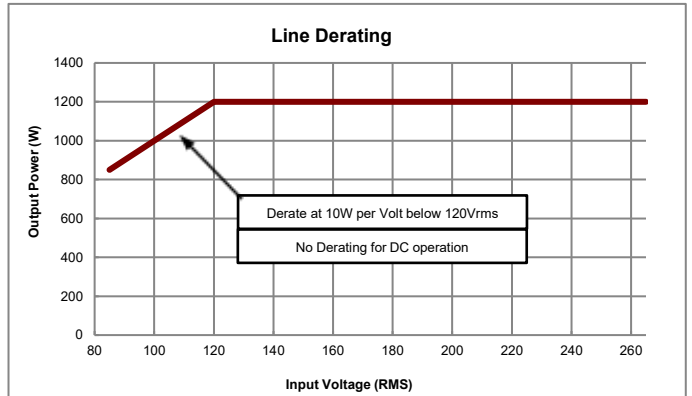

Depending on the application conditions, one or both of the de-ratings may apply. Where both apply, calculate each de-rating in turn and fill the result from the first calculation into the second calculation.

Example: What are the NEVO+1200 input and output module de-ratings at 60°C at 100V line?

Input module line de-rating

$= Prated - (10W * (120V - V_{in})) = 1200W - (10W * (120V - 100V)) = 1000W$

Input module temperature & line de-rating

$= Prated - [(Temp - 50^{\circ}C) * (0.025 * Prated)] = 1000W - [(60^{\circ}C - 50^{\circ}C) * (0.025 * 1000W)] = 750W$

150W Output module temperature de-rating

$= Prated - [(Temp - 50^{\circ}C) * (0.025 * Prated)] = 150W - [(60^{\circ}C - 50^{\circ}C) * (0.025 * 150W)] = 112.5W$

Efficiency

The efficiency of the configured NEVO+1200 product is dependent on parameters such as input line voltage, load level and on the combination of output modules. The plots below show typical efficiencies of a NEVO+1200 over the full load and line voltage range and fitted with four of each type of single output module, equally loaded.

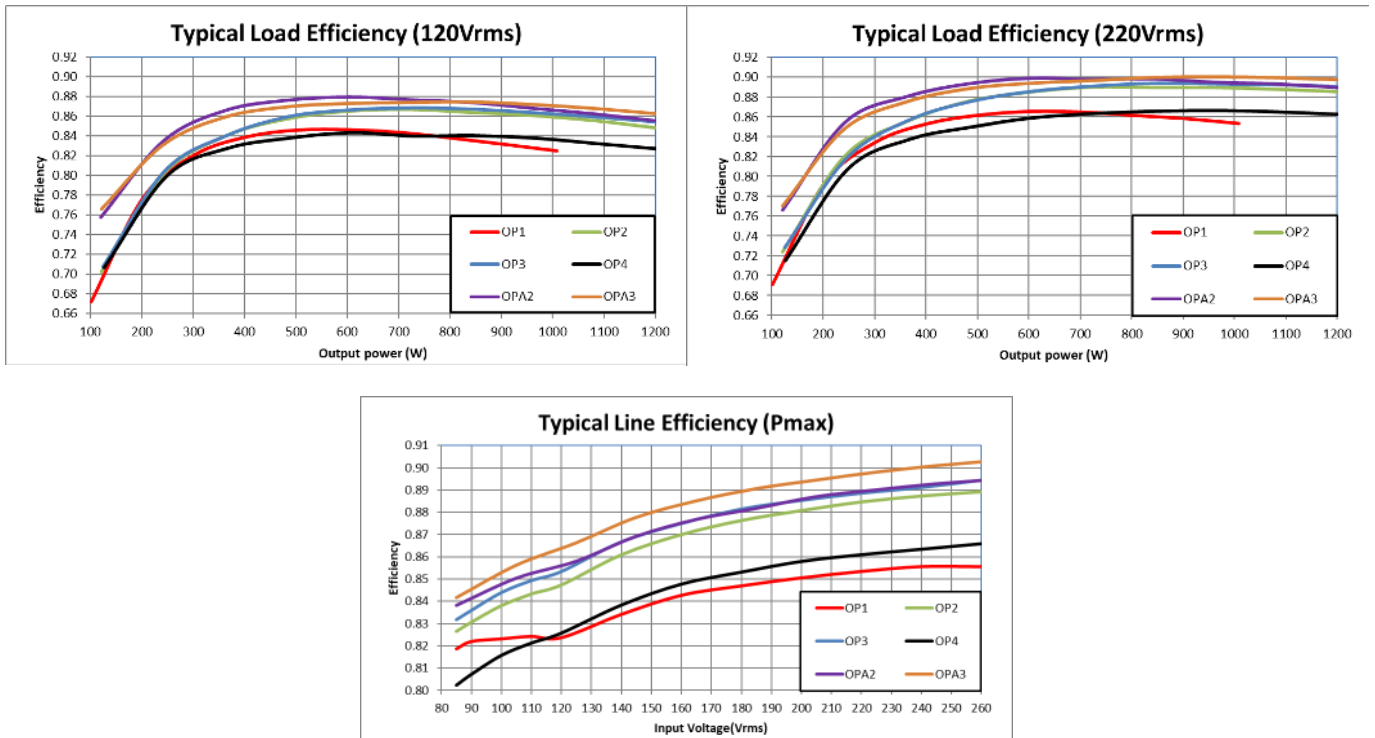

An estimate of the efficiency for any particular system may be obtained from these graphs using the procedure outlined in the example below.

Example: Estimate the efficiency of an NEVO+1200-11223344, at 160Vrms input and 100W load on each output?

1. Define load efficiencies for each output module at the specified load and 220V.
2. Define change in efficiency from 220Vrms to 160Vrms for each output module.
3. Sum the values from step one and two for each output module.
4. Calculate the average efficiency for the total system.

Step	Details	Slot A OP1	Slot B OP1	Slot C OP2	Slot D OP2	Slot E OP3	Slot F OP3	Slot G OP4	Slot H OP4
1	ϵ_{220} (Load chart)	0.86	0.86	0.89	0.89	0.895	0.895	0.86	0.86
2	$\Delta\epsilon_{(220-160)}$ (Line chart)	-0.01	-0.01	-0.015	-0.015	-0.015	-0.015	-0.01	-0.01
3	$\epsilon_x = \epsilon_{220} + \Delta\epsilon_{(220-160)}$	0.85	0.85	0.875	0.875	0.88	0.88	0.85	0.85
4	$\epsilon_{AVE} = (\epsilon_1 + \epsilon_2 + \epsilon_3 + \epsilon_4 + \epsilon_5 + \epsilon_6 + \epsilon_7 + \epsilon_8) / 8$	0.86375							

Signalling

Output Signals

The NEVO+1200 has two isolated output signalling sections arranged in groups, the first covers slots A to D and the second covers slots E to F. To reduce cabling in the end system, all major input and output signals and the global 5V bias supply for each group are wired to a single signals circuit that is accessed through the connectors (J2a and J2b) located at the output side of the chassis as shown in the diagram below.

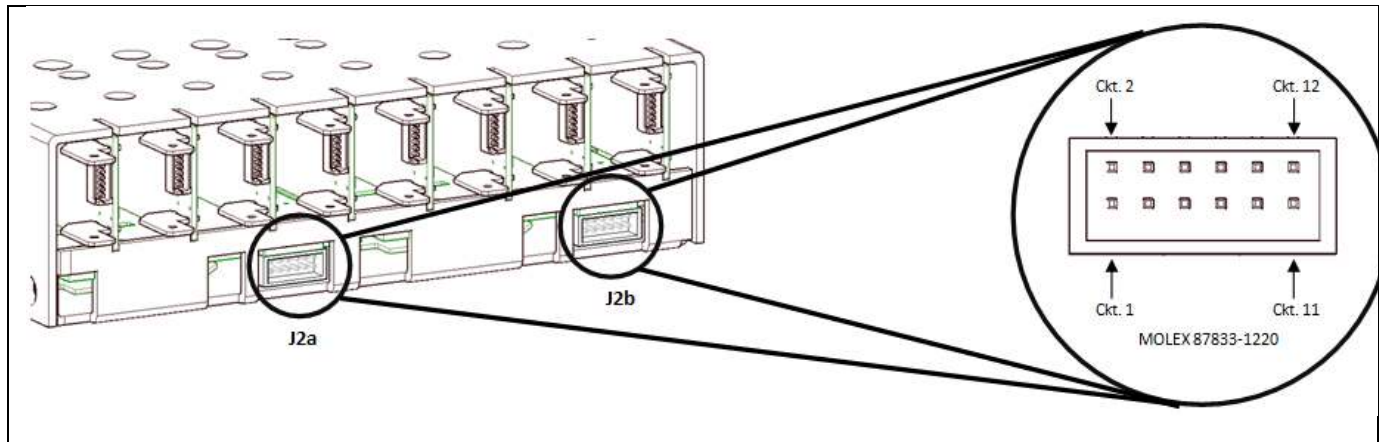

J2a				J2b			
Pin	Name	Description		Pin	Name	Description	
1	PG1	Power Good	Slot A	1	PG5	Power Good	Slot E
2	INH1	Inhibit		2	INH5	Inhibit	Slot F
3	PG2	Power Good	Slot B	3	PG6	Power Good	
4	INH2	Inhibit		4	INH6	Inhibit	Slot G
5	PG3	Power Good	Slot C	5	PG7	Power Good	
6	INH3	Inhibit		6	INH7	Inhibit	Slot H
7	PG4	Power Good	Slot D	7	PG8	Power Good	
8	INH4	Inhibit		8	INH8	Inhibit	Slot E-F
9	GINH1	Group 1 inhibit	Slot A-D	9	GINH2	Group 2 inhibit	
10	ACOK1	AC mains signal		10	ACOK2	AC mains signal	
11	+5V1	Global 5V Bias		11	+5V2	Global 5V Bias	
12	COM1	Common		12	COM2	Common	

Note that for modules requiring more than 1 slot, the INHx and PGx use the highest number available for x. The other controls will have no function. E.g. For an OPA2 fitted in slots AB, INH1 & PG1 have no function while INH2 and PG2 provide the usual functions for the module.

All of the signals are referenced to the relevant group bias supply common rail (COM) and external control and/or monitoring circuits can be easily powered and interfaced to the PSU through these connectors. Both entire signals circuits are fully medically isolated and can be considered a SELV output. The table below lists the isolation voltages.

Signals isolation voltages		
Signals to Input	4000 ⁽¹⁾	Vac
Signals to Chassis	250	Vdc
Signals to Output	250	Vdc
Notes	1. Testing an assembled unit to 4000VAC may cause damage. Please refer to application note (APN-002) on Vox Power website or contact Vox Power representative.	

Bias supplies (+5V1 & +5V2 [Power])

The NEVO+1200 series has three separate isolated bias supplies, one (J6) located near the AC mains input connector (J1) and two more located at the output side connectors (J2a & J2b).

Both output side bias supplies generate 5V and are rated up to 1A. These supplies are available whenever the AC mains voltage is connected and the input module is operating correctly. A shutdown through the SD pin on J6 or any of the following abnormal conditions will cause the entire unit to latch off and will disable both of these 5V bias supplies:

- Over temperature of any part of the unit
- Over voltage on the output
- Internal over current (device failure)

AC Mains Signal (ACOK [Output])

An ACOK signal is provided on each output group to indicate to the user that the AC mains voltage is applied and the input module is operating correctly. The output signal is driven from an internal operational amplifier as shown in the following diagram. Under normal operating conditions this signal gives a warning of 5ms before the output voltage falls below the power good threshold. A shutdown through the SD pin on J6 or any of the following abnormal conditions may cause the entire unit to latch off without the minimum 5mS ACOK warning:

- Over temperature of any part of the unit
- Over voltage on the output
- Internal over current (device failure)

Power Good Signals (PG1-PG4& PG5-PG8 [Output])

Each output module provides a power good (PG) signal to indicate when the output voltage is above approximately 90% of the pre-set voltage for that module. Each PG signal on an output module is internally connected through an opto-isolator to the group signals circuit, which buffers the signal through a PNP transistor with a 10k pull down resistor, as shown.

The LED on the front of each module gives a visual confirmation of the PG status.

Note that remote adjustments of the output voltage using the Vcontrol and Icontrol pins do not change the PG signal threshold. The PG threshold is always approximately 90% of the voltage set with the manual potentiometer.

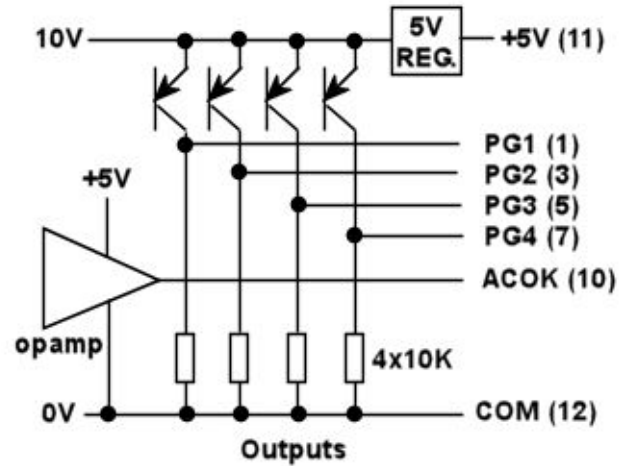

Output Inhibits (INH1-INH4& INH5-INH8, GINH1 & GINH2 [Input])

The signals circuit provides an inhibit input to disable each output module individually and global inhibit inputs (GINH1 & GINH2) to inhibit each group of modules simultaneously. Each inhibit input is internally connected through an opto-isolator to the respective output modules. The basic internal electrical circuit and timing diagrams are shown below. Typically, $t_{OFF} = 100 \mu s$ and $t_{ON} = 8 ms$.

To inhibit each output module individually, GINH for the relevant group should be connected to COM, and 5V applied to the appropriate input INH1/2/3/4/5/6/7/8. To start with all outputs inhibited and then enable them individually, GINH should be connected to +5V, then pull down the appropriate input INH1/2/3/4. If GINH is left unconnected, then all INH inputs will all behave as global inhibit inputs. i.e. 5V on any INH input will disable all outputs in that group.

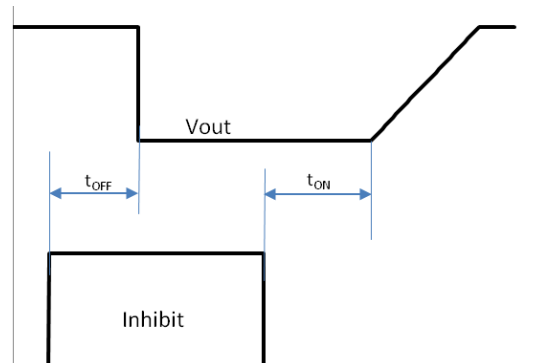
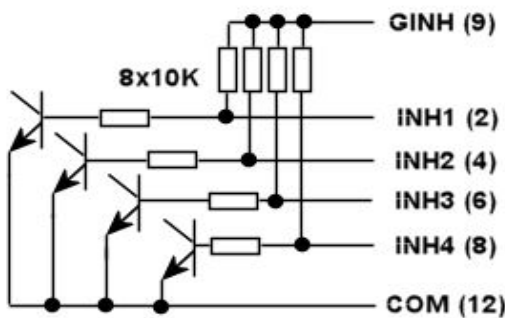

Input Signals

The input side signals are located on J6 near the AC mains input connector. The signals consist of a 5V bias supply and a shutdown pin (SD). The input bias supply generates 5V, is rated up to 0.5A and is "Always on" when the AC mains is connected regardless of whether the PSU has been shutdown.

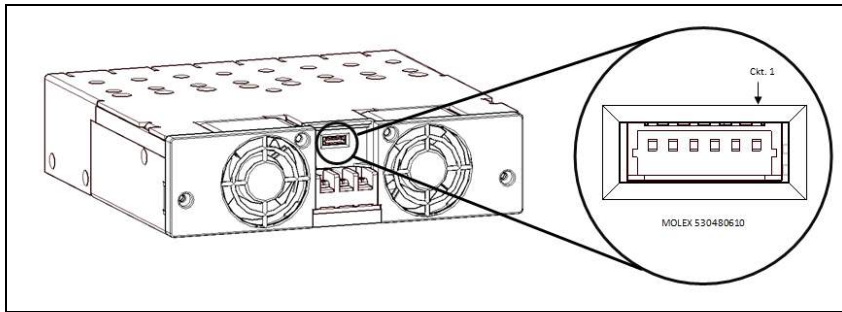

Pin	Name	Description
1	COM	Common
2	+5V	"Always on" 5V Bias
3	SD	Shutdown
4	Reserved	
5	Reserved	
6	Reserved	

The sequence to shutdown and restart the PSU is shown in the timing diagram below.

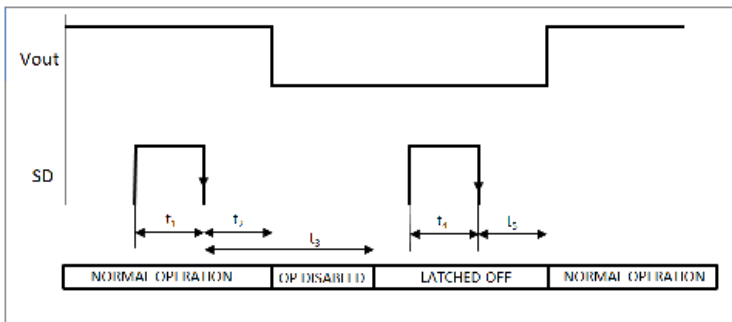

$t_1 \geq 5\text{mS}$, $t_2 \leq 25\text{mS}$, $t_3 \geq 200\text{mS}$, $t_4 \geq 500\text{mS}$, $t_5 \leq 600\text{mS}$

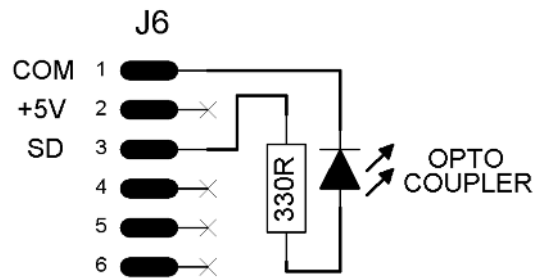

Internal circuit

The SD pin is negative edge triggered. To shut down the PSU during normal operation, 5V must be applied for a minimum of t_1 then released. After a period of t_2 the main outputs will shut down but the bias voltages 5V1 and 5V2 will remain on. If the SD pin remains low for a period of t_3 the PSU will shut down and stay latched in that state. If the SD does not remain low for a period of t_3 then the outputs will turn on again. When in the latched state, the PSU will resume normal operation when 5V is applied to the SD pin for a period of t_4 and released for a period of t_5 .

This operation is perfect for push button or microcontroller on/off control using the recommended circuits below.

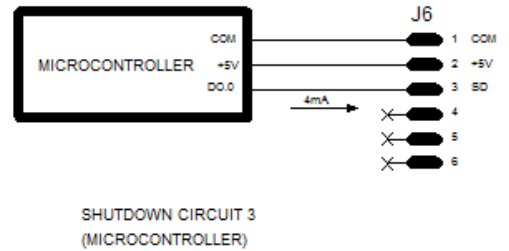
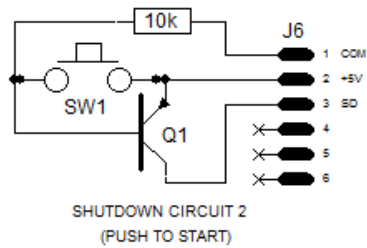
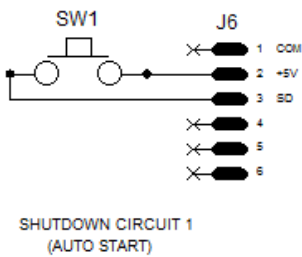

All pins on the J6 connector are isolated to the following specification.

J6 Signals isolation voltages		
Signals to Input	4000	Vac
Signals to Chassis	250	Vdc

Single Output module operation

Power Profile

The power profile diagram below is a voltage/current plot that together with the associated table provides details of the main features of the currently available output modules.

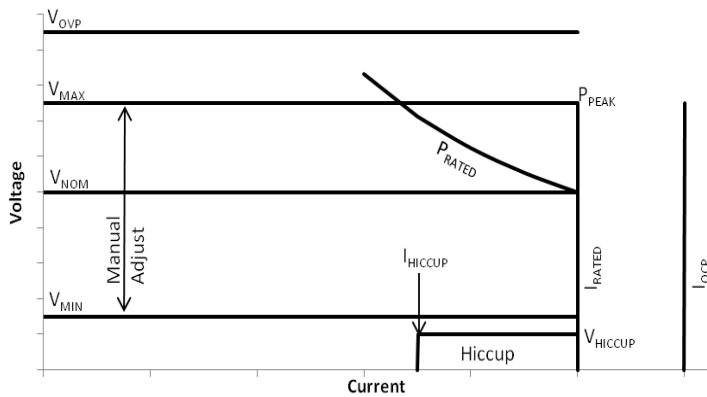

Parameter	OP1	OP2	OP3	OP4	OPA2	OPA3
V _{NOM} (V)	5	12	24	48	12	24
V _{MIN} (V)	1.5	4.5	9	18	4.5	9
V _{MAX} (V)	7.5	15	30	58	15	30
V _{OVP} (V)	9.5	18	36	62	18	36
I _{RATED} (A)	25	15	7.5	3.75	25	15
I _{OCP} (A)	27.5	16.5	8.25	4.125	27.5	16.5
V _{HICCUP} (V)	1	2	4	4	2	4
I _{HICCUP} (A)	22	13.2	6.6	3.3	22	13.2
P _{RATED} (W)	125	150	150	150	300	300
P _{PEAK} (W)	187.5	225	225	217.5	375	450
Slots	1	1	1	1	2	2

Output Voltage Adjustment

Each output can be adjusted within the range as described in the table above or in the datasheet. Voltage adjustment can be achieved by two methods;

1. Manual potentiometer adjustment

Using the manual adjust potentiometer, the preset output voltage (V_{SET}) of each output module is adjustable over the entire range of V_{MIN} to V_{MAX} as specified in the power profile table above. A clockwise rotation of the potentiometer results in an increase of the output voltage while an anti-clockwise rotation results in a decrease of the output voltage.

2. Remote Voltage Programming

Using remote voltage programming, the output voltage may be adjusted beyond the V_{MIN} and V_{MAX} range specified in the power profile table above. However, certain precautions must be taken to ensure correct operation. Please see the "Advanced output module features" section for more details.

Over Voltage Protection (OVP)

In the event of an output module fault, the modules are protected against excessive output voltages. This is implemented as a fixed voltage threshold (V_{OVP} , in the table above) and if the output voltage exceeds this threshold the entire chassis will be latched off. To resume operation of the unit, disconnect the AC input voltage for 20 seconds, remove the faulty output module and reconnect the AC input voltage.

Note that no warning is given on the AC_OK signal for faults of this type.

Over Current & Short Circuit Protection (OCP & SCP)

For increased safety and reliability all output modules in the NEVO series have over current and short circuit protection. The over current threshold is typically set at 120% of the rated current and has a constant current, straight line characteristic that reduces the output voltage as the load resistance decreases. If the output voltage falls below the hiccup voltage threshold (V_{HICCUP}) the module enters short circuit protection mode. In this mode the output module uses a hiccup scheme to reduce system losses and potential damage. When in this mode, the output will be enabled for approximately 3% of the time, disabled for 97% and will attempt to restart at approximately 125 ms intervals. The module remains in this state until the short circuit condition is removed, at which point the module returns to normal operation.

Reverse Current Protection (RCP)

The standard output modules use synchronous rectification in the output stages to achieve high efficiency and as a result the outputs can both source and sink current. The sink current is internally limited to approximately -6% of the maximum rated current. However, in applications where the output modules are connected to external power sources such as batteries or other power supplies certain precautions must be observed to prevent damage to the unit.

The outputs should never be directly connected to external power sources without some form of reverse current protection such as an external diode or controlled mosfet. If protection is not used, large reverse currents which will ultimately result in damage to the unit will occur, especially when the AC mains is disconnected.

Output Module Average and Peak Power

All modules have an average and peak power rating. The average power of each unit must at all times remain below it's specified limit. However, each output can deliver up to 150% of it's average power rating for a maximum of 5 seconds at 50% duty cycle, subject to the current limit not being exceeded and subject to the overall average power drawn being less than the specified average power rating (including any input derating due to temperature or line voltage). The available peak power is a function of the output voltage and maximum current for each module. Full peak power is only possible when the output voltage is adjusted to V_{MAX} and the maximum current is drawn from the module. Note that both average and peak power ratings are subject to the same temperature derating as the input module (derate by 2.5% per °C above 50°C), but are not subject to any line derating.

Start-up & Shut Down

All outputs are designed to have a regulated monotonic start-up with a rise time of approximately 3ms as shown in the diagram right. The power good signal stays low until the voltage exceeds the power good threshold ($\approx 90\%$).

Where multiple output modules are used, the default start up scheme is ratio-metric with all outputs starting at the same time as shown in the diagram right. External control circuits may be used to implement tracking or sequenced start up if necessary.

The outputs are not designed to start into a pre-biased load and may discharge any externally capacitance before beginning to ramp the output voltage up in the normal way.

At shutdown the outputs enter a high impedance state. Where no external load is present it may take some time for the voltage to decay. When driving inductive loads, care must be taken to limit the voltage at the output terminals so as to prevent damage to the unit.

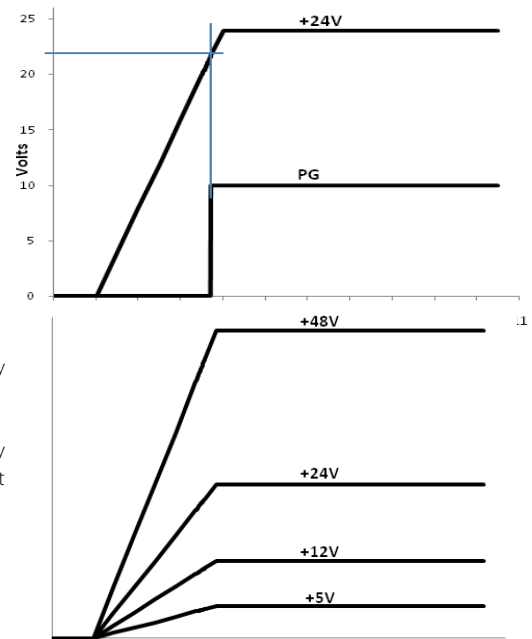

Synchronisation

All output modules in the same chassis are synchronised. The typical operating frequency is 260kHz and paralleled or series connected units will not produce beat frequencies.

Ripple and Noise

The ripple and noise figures stated in the datasheet are defined based on a standard measuring method. To obtain the same results the same test setup must be used and care must be taken to eliminate any parasitic noise pickup. The diagram below shows details of the setup and also sources of noise pickup.

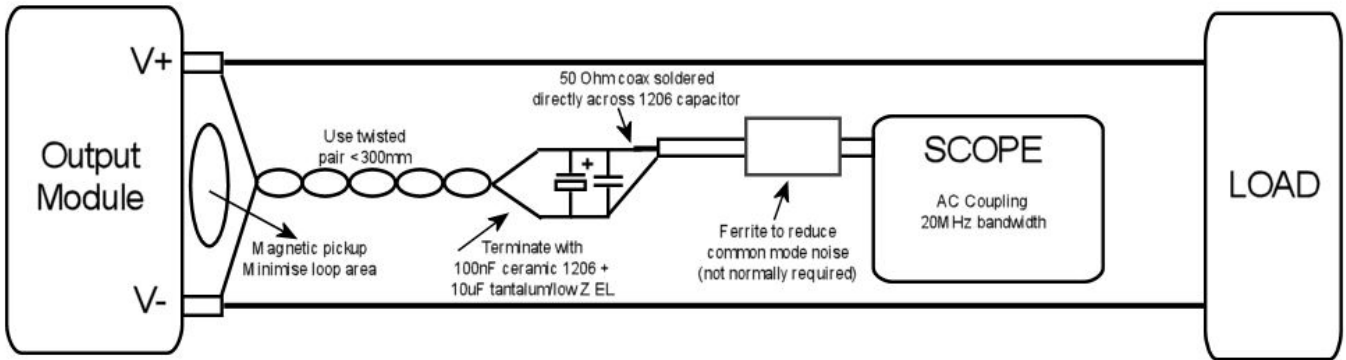

Over Temperature Protection (OTP)

Each output module is protected against excessive temperatures. In the event of the internal temperatures exceeding safe levels the entire unit may be latched off. To resume operation of the unit, disconnect the AC input voltage for 20 seconds, ensure external ambient temperatures are within specifications and then reconnect the AC input voltage. Note that no warning is given on the AC_OK signal for faults of this type.

Transient Response

The NEVO output modules have been especially designed to have high reliability. To achieve this all electrolytic capacitors have been eliminated from the design. As a result of this, high dynamic load transients can cause relatively high voltage deviations at the output and although the outputs have a very high loop bandwidth with typical recovery times of less than 100µs, the voltage deviations may still be excessive for some applications.

An example application is detailed in the diagram below and shows typical responses at the terminals of the output module and at the load. Notice that the voltage deviation due to cable inductance exceeds the module response and hence a capacitor located at the module terminals will have little effect at the load. The optimum solution is to locate a low impedance electrolytic capacitor at the load which will eliminate the inductive cable drop and also reduce the typical voltage deviation at the module.

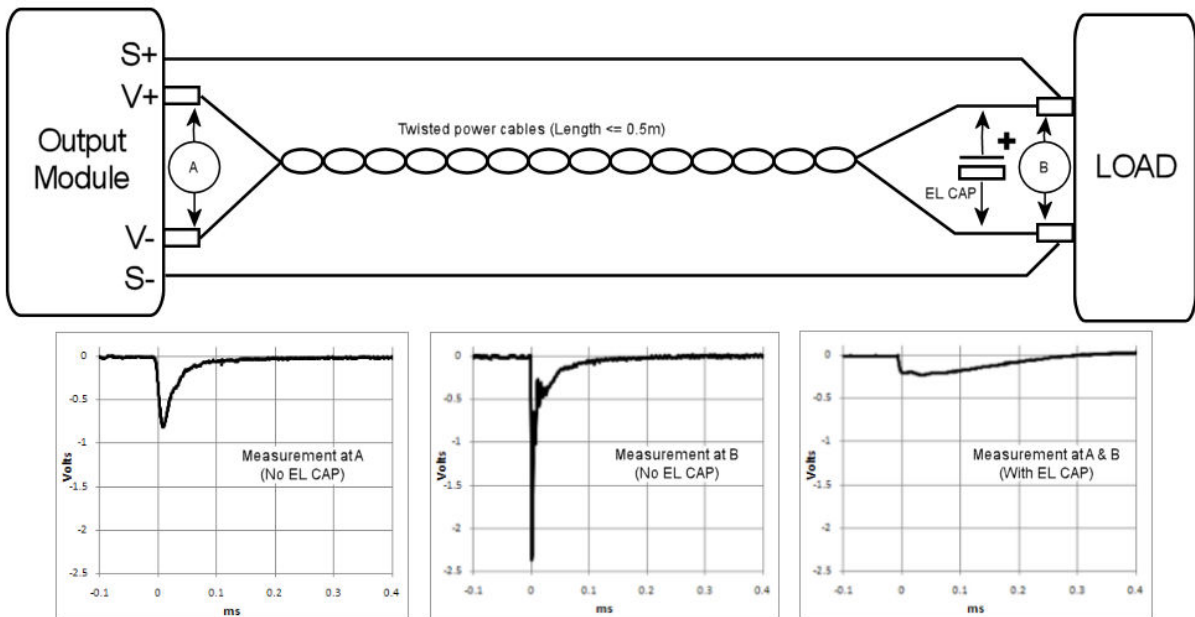

Advanced Single Output Module Features

Remote Voltage Programming (External Voltage Control)

The output voltage of the module can be adjusted using an external voltage source connected between the COM and Vcontrol pins on the signals connector J5 as shown below.

In this configuration the output voltage will follow the typical equation below,

$V_o = V_{set}((1.8 - V_{ctrl}) / 0.6)$, where V_{set} is the manual preset voltage of the module.

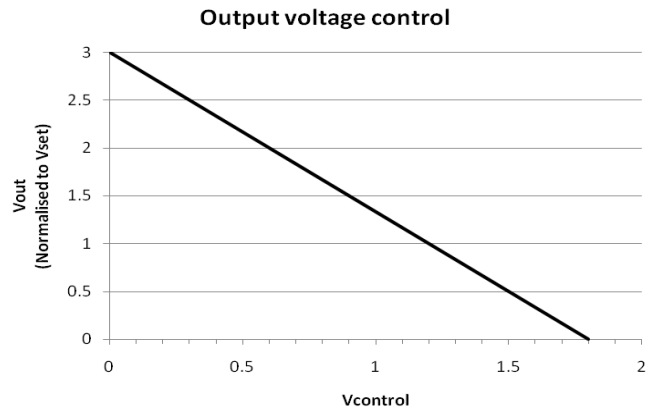
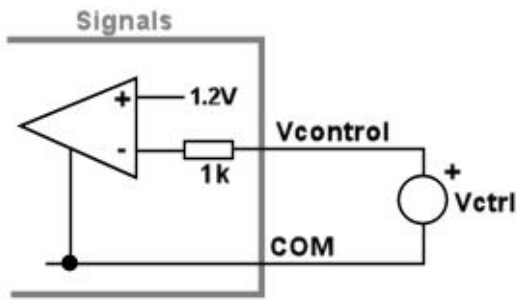

The output voltage can be controlled from 0% to 300% of the preset voltage using this control method. However, care must be taken to ensure the output voltage does not exceed the OVP level, as this is considered a safety hazard and will latch the entire unit off. To determine the level of control voltage that will trigger OVP, insert V_{ovp} into the equation above.

Example: $V_{ovp} = 9.5V$, $V_{set} = 5V$;

$$\Rightarrow V_{ctrl} = 1.8 - (V_{ovp} * 0.6 / V_{set}) = 0.66V$$

Hence, V_{ctrl} should never fall below 0.66V, otherwise OVP may latch the entire unit off.

Alternatively, by manually adjusting the output voltage to less than 1/3rd of the OVP voltage ensures that OVP can never be tripped by remote voltage control.

Also, remote adjustment of the output voltage using the Vcontrol pin does not affect the preset power good threshold. Hence, remotely adjusting the output voltage below $0.9 * V_{set}$ will cause the power good signal to go low.

Where tight voltage adjustment tolerances are required, it is recommended to use external circuitry to provide closed loop control of the Vcontrol pin.

Remote Current Programming (External Voltage Control)

The output current limit of the module can be reduced using an external voltage source connected between the COM and Icontrol pins on the signals connector as shown below. In practice this also means that the output can be used as a modulated or constant current source.

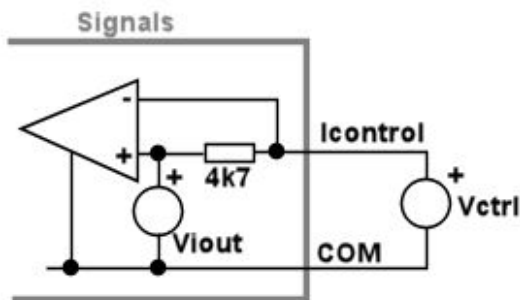

In the diagram above, V_{i_out} is an internal voltage source that is proportional to the internal inductor current and approximates the equation,

$$V_{i_out} = 0.6 + (I_{out}/I_{rated} * 1.25),$$

where I_{rated} is the maximum rated current for the module.

In this configuration the output current limit will approximate the following equation,

$$I_{limit} = (V_{ctrl} - 0.6) * I_{rated} * 1.25,$$

where I_{rated} is the maximum rated current for the module.

It is not possible to increase the maximum current limit of the module, and control voltages (V_{ctrl}) exceeding 1.53 V will have no effect on the current limit.

When using an output module as a modulated current source, the output voltage should be manually adjusted to the maximum that will be required by the application and this will be the upper voltage limit. Once the load is connected, the output current can then be modulated by applying a control voltage as described above.

Note that the power-good threshold level is fixed and defined by the manually preset voltage. Hence, while the output module is limiting or modulating the output current the PG signal may go low.

Where tight current adjustment tolerances are required, it is recommended to use external circuitry to provide closed loop control of the Icontrol pin.

Output Current Measurement

The output current of the module can be measured using the $I_{control}$ signal. If this pin is not loaded its output voltage will follow the typical equation,

$$V_{i_out} = 0.6 + (I_{out}/I_{rated} * 1.25),$$

where I_{rated} is the maximum rated current for the module.

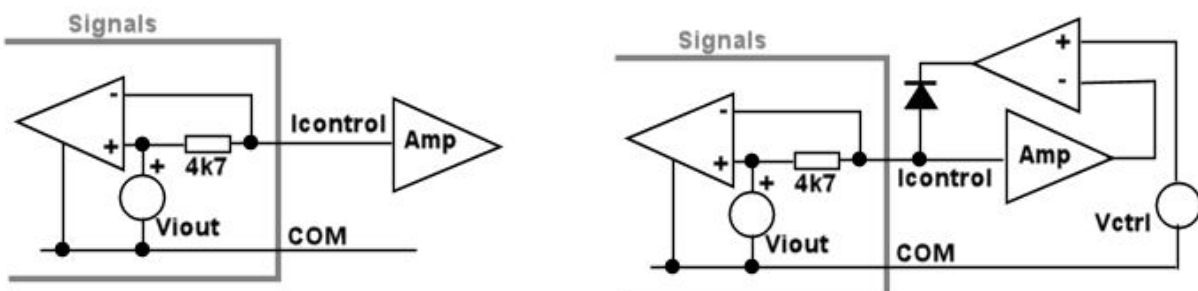

Note that the $I_{control}$ output voltage is representative of the internal inductor current not the actual load current. However, this will only have an influence during dynamic events. It is recommended to add an external amplifier (as shown above left) when using the $I_{control}$ signal to measure the output current as loading the $I_{control}$ signal, even with microamps can cause the current limit to be reduced. If it is required to measure the output current and adjust the output current limit simultaneously, this can be achieved by using a clamp circuit instead of a voltage source to adjust the current limit, while continuing to use an amplifier to measure the output current. An example circuit is shown above right. In this case V_{ctrl} will control the current limit while the amplified $I_{control}$ signal will provide a measurement of the output current.

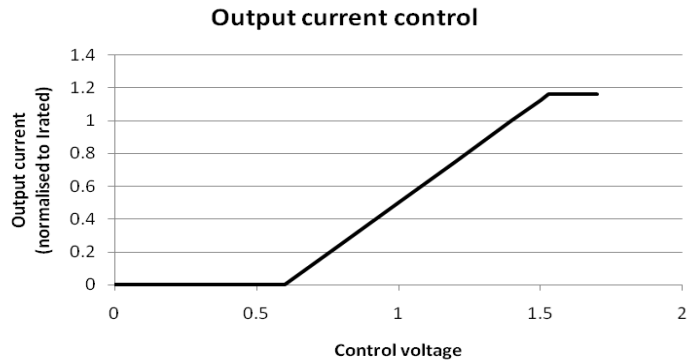

Remote Sensing

Remote sensing is available on all output modules and can be used to compensate for a voltage drop in the power leads connecting the power supply to the load. To implement remote sensing connect the positive sense pin (S+, connector J5.2) to the positive side of the remote load and the negative sense pin (S-, connector J5.1) to the negative side of the remote load. The voltage will be regulated at the points where the sense cables are connected.

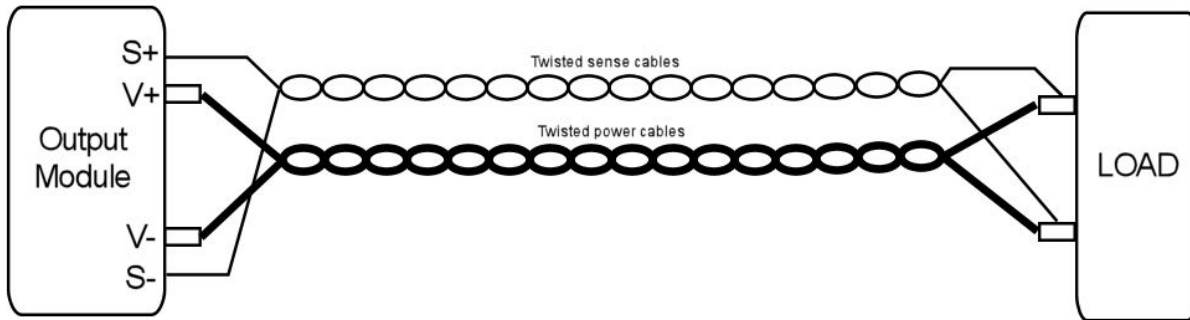

Active protection against damaged power cables or accidental power cable removal is provided and prevents damage to the unit in each case. An internal circuit measures the voltage between S+ to V+ and S- to V-, when this voltage exceeds the thresholds specified in the datasheet, the output voltage is reduced to benign levels. During system design, care must be taken to ensure power cables have a sufficiently low voltage drop at maximum load current to ensure this protection does not activate unintentionally.

In systems where remote sensing is not used, the output voltage at the power terminals will be slightly higher than that at the sense terminals. This voltage difference is termed, open sense offset and occurs due to internal bias currents in the sensing circuit. Factory set units are set with the sense cables connected unless otherwise specified.

Local Bias Supply

A local non-isolated +5 V bias supply is provided on each output module (+5 V on J5.6, referenced to COM on J5.5). This supply is intended to power interface circuits for monitoring and controlling the output modules, such as amplifying the current output signal as described earlier. The output can supply up to 10mA maximum, and exceeding this can damage the unit.

Also, as COM is connected to an internal voltage that is **NOT** equivalent to S- or V-, particular attention must be given to grounding issues when interfacing COM to any control circuit in the application. Connecting COM to S- or V- may result in damage to the unit.

Series Connected Outputs

NEVO output modules of the same type can be series connected to achieve higher output voltages. The following instructions must be followed for output modules configured in this manner.

WARNING!
Energy and Voltage hazards may arise when individual modules are series connected.
See the Safety section for more details.

WARNING!
When modules are seriesed, their inhibit lines (J2), if used, should be paralleled.
Inhibiting seriesed modules individually may cause damage

Isolation to Ground

Care must be taken not to exceed the output module isolation to chassis ground when series connecting modules. Each output module is rated for 250 volts maximum between each output terminal and chassis ground. Exceeding this voltage may damage the module.

Remote Sensing

For series connected modules, remote sensing is achieved by connecting the upper most positive sense terminal (S+) and the lower most negative sense terminal (S-) from the series of modules to their respective load regulation points. All inner sense terminals in the series must be daisy chained i.e. S+ to S- from the first module in the series to the last module in the series. An example of two series connected modules is shown below.

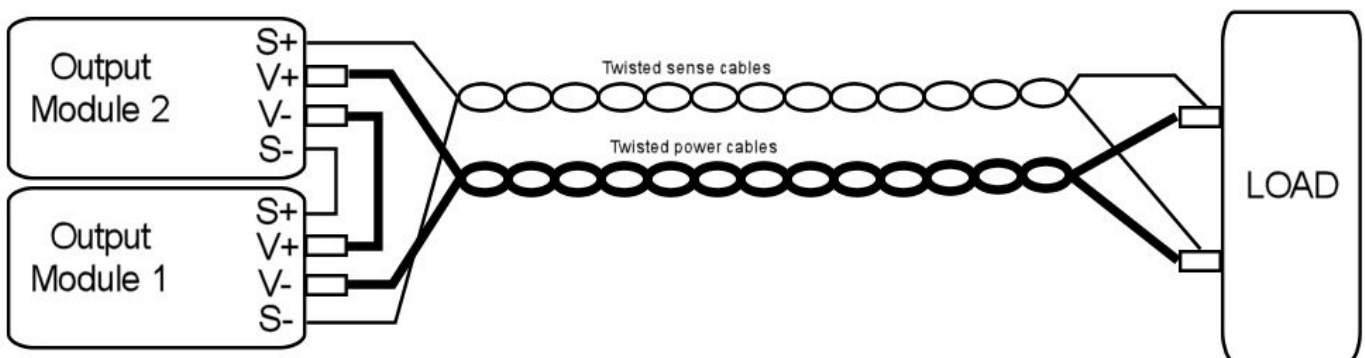

Series connected Remote Voltage/Current Control

Remote voltage and/or current control is possible with series connected output modules using the advanced V-control and I-control functions described earlier. However, individual control of each module can be complex as the various control terminals are referenced to the positive output of the preceding module and require the use of multiple isolated control voltages to attain control over the full voltage range. In practice, individual control of each module is rarely required and a more straightforward method is to control all outputs simultaneously with a single control voltage. With NEVO output modules this is achieved with the use of the NEVO Series Tracker Interface, the datasheet for this interface is available from the Vox Power website i.e. www.vox-power.com. By using the series tracker interface all modules in a series can be controlled by a single control voltage that can be referenced to the COM (J5.5) pin on any module.

SELV Precautions

Where series combinations of output modules exceed 60 V, the output can no longer be considered SELV (Safety Extra Low Voltage) and hence the final equipment manufacturer must provide suitable protection for both users and service personnel.

Parallel Connected Outputs

NEVO single type output modules of the same type can be paralleled in any number within the same chassis to achieve higher output currents. When paralleled, the outputs can operate in two distinct modes, Normal parallel mode or Share parallel mode.

WARNING!

Energy hazards may arise when individual modules are paralleled.
See the Safety section for more details.

WARNING!

When modules are paralleled, their inhibit lines (J2), if used, should also be paralleled.
Inhibiting paralleled modules individually may cause damage

Normal parallel mode

For normal parallel mode, the positive power cables should be connected together and the negative power cables should be connected together. No other connections are required.

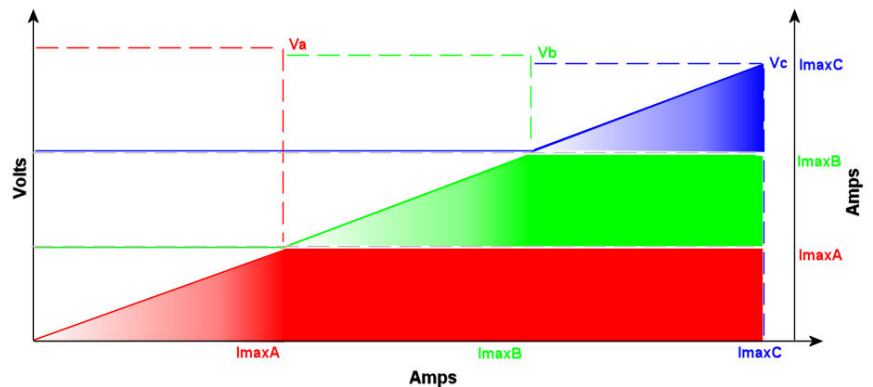
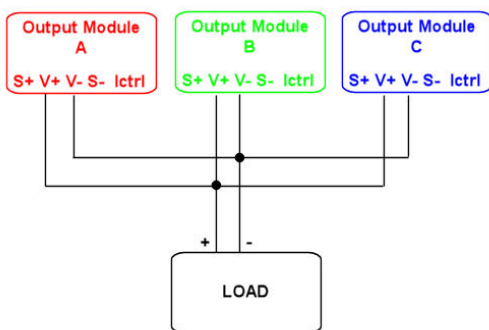

In this mode the highest adjusted output module will supply all of the load current until its current limit is reached. If the load demand exceeds this level the output voltage will drop to the level of the next highest adjusted module and that module will begin to supply the load current while the first module continues delivering full current. This process repeats for the total number of paralleled modules. The diagram above shows the VI curve for such a system.

For best output voltage stability, the output voltages of each paralleled module should be adjusted as close as possible.

Output modules that are not delivering current will typically sink a small amount of current from the other outputs, but this will not exceed -6% of each modules maximum rated current.

Typically, system reliability is reduced in this mode as the higher adjusted modules will do most of the work with the lower adjusted modules only delivering current during peak load demand.

Share Parallel Mode

In Share parallel mode, the outputs are paralleled as before and the I-control pin of each module connected together as shown in the diagram below.

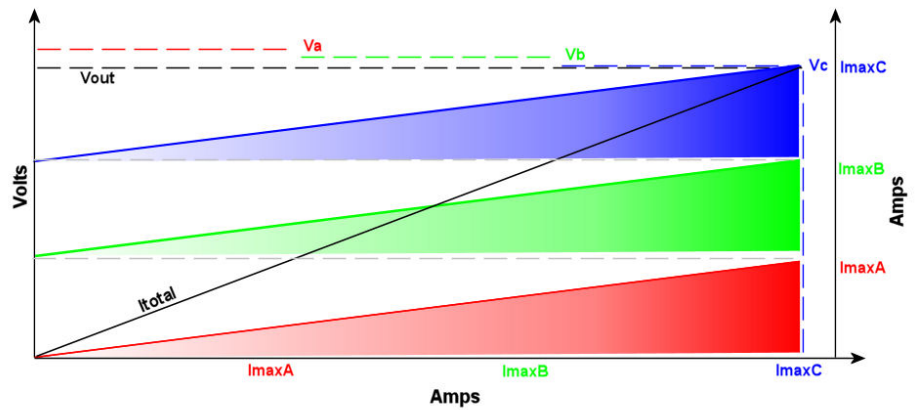
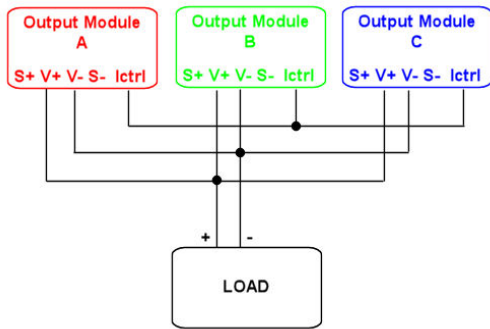

Connecting the I-control pins together forces all the outputs to deliver the same current, ensuring that the system reliability is maximised and the work load is distributed evenly across all paralleled modules.

In this mode the lowest adjusted output module will determine the actual output voltage and all higher adjusted outputs will reduce their voltage. There may be a small amount of circulating current between the modules, approximately 6% of the maximum rated current for each module.

The current output signal (I-control) can still be used to measure the output current but it must be scaled by N, where N is the number of paralleled modules.

WARNING!

Care must be taken to avoid differential voltages between the negative power output terminals of the paralleled modules as this can cause errors at the control pins. To avoid this, it is recommended that a low impedance connection be made between the negative power terminals close to the PSU output and cables then connected from this common point to the load.

Paralleling Across Multiple Chassis

Paralleling across multiple chassis is not possible or recommended without external protection (such as external diodes or controlled MOSFETs) to prevent circulating currents between each chassis. Failure to provide such protection may result in damage to the power supplies. Consult Vox Power for details on how best to implement such applications.

When modules are paralleled across multiple chassis, the outputs in each chassis will not be synchronised and the peak to peak output ripple may contain beat frequencies in the audio spectrum.

Parallel Remote Sensing

Remote sensing can be used as normal with paralleled modules. The sense lines (S+ and S-) from each of the output modules should be connected together, S+ to S+, and S- to S- as shown below. This should be done close to the power supply output and a single pair of cables brought from these sense lines to the load. Keeping cable lengths to a minimum and using twisted pairs where necessary will help reduce noise pickup in the sense lines.

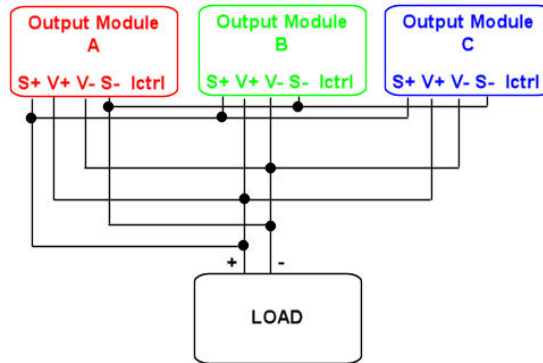

N+1 Configurations

When using N+1 redundant configurations, a suitably rated diode (or controlled MOSFET) must be used on each output to prevent a device failure from causing a system failure. However, the diode introduces voltage drops between the supply and the load that significantly degrade the load regulation. To counteract this, the remote sense lines can be used to regulate the voltage at the load as shown below.

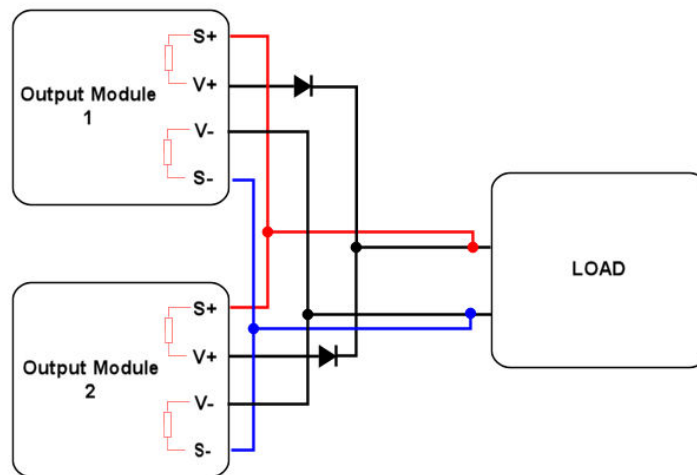

Typically, this configuration can damage the internal sense resistors used within a power supply. However, the NEVO outputs have integrated protection to prevent this type of damage and are completely N+1 compatible without any additional external protection circuitry. Note that only the positive sense terminal is protected and diodes should be used in the positive connection only.

Paralleled Remote Voltage/Current Adjustments

Remote voltage programming with paralleled outputs can be achieved by simply joining all $V_{CONTROL}$ and COM pins together and applying the external control voltage between COM and $V_{CONTROL}$.

Remote current programming with paralleled outputs can be achieved by joining all $I_{CONTROL}$ and COM pins together but directly applying an external control voltage would override the current share signal and force the outputs to operate in normal parallel mode. Instead it is required to clamp the $I_{CONTROL}$ bus voltage using a circuit similar to that shown below.

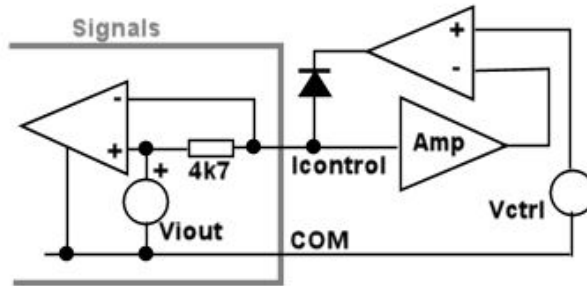

It is not recommended to use remote voltage/current programming in normal parallel mode.

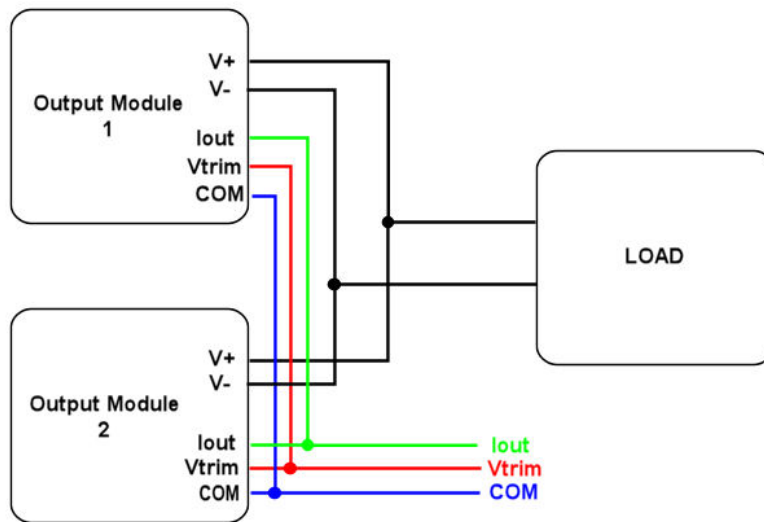

WARNING!

Care must be taken to avoid differential voltages between the negative power output terminals of the paralleled modules as this can cause errors at the control pins. To avoid this, it is recommended that a low impedance connection be made between the negative power terminals close to the PSU output and cables then connected from this common point to the load.

Dual Output module operation

Power profile

The power profile diagram below is a voltage/current plot that together with the associated table provides details of the main features of the currently available dual output modules.

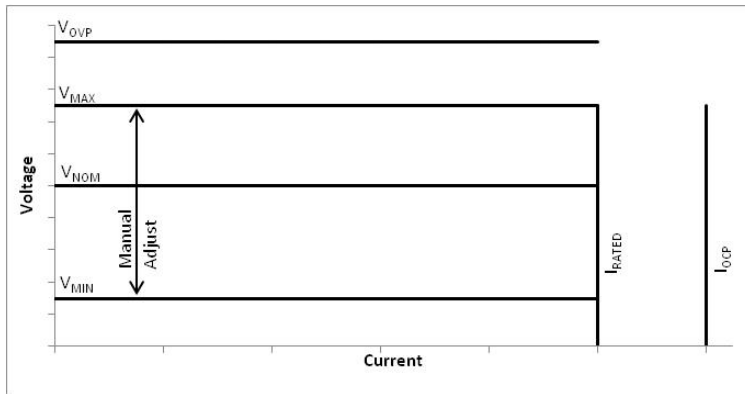

Parameter	OP5*		OP8	
	Top	Bottom	Top	Bottom
V _{NOM} (V)	12	12	24	24
V _{MIN} (V)	3.3	3.3	-	-
V _{MAX} (V)	15	15	-	-
V _{OVP} (V)	22	22	30	30
I _{RATED} (A)	5	5	3.125	3.125
I _{OCP} (A)	6.5	6.5	4.5	4.5
P _{RATED} (W)	75	75	75	75

* Specifications are for updated OP5 modules. Serials beginning with 18xxxxxxxx.

Output voltage adjustment

Each output can be adjusted within the range as described in the table above or in the datasheet. Voltage adjustment can be achieved using the manual adjust potentiometer, the preset output voltage (V_{SET}) of each output module is adjustable over the entire range of V_{MIN} to V_{MAX} as specified in the power profile table above. A clockwise rotation of the potentiometer results in an increase of the output voltage while an anti-clockwise rotation results in a decrease of the output voltage.

Remote voltage programming is not available on dual output modules.

Over Voltage Protection (OVP)

In the event of an output module fault, the modules are protected against excessive output voltages. This is implemented as a fixed voltage threshold (V_{OVP} , in the table above) and if the output voltage exceeds this threshold the entire chassis will be latched off. To resume operation of the unit, disconnect the AC input voltage for 2 minutes, remove the faulty output module and reconnect the AC input voltage.

Note that no warning is given on the AC_OK signal for faults of this type.

Over Current Protection (OCP)

For increased safety and reliability all dual output modules in the NEVO series have over current protection. The over current threshold is typically set at 130% of the rated current and has a hybrid constant current - hiccup mode characteristic. If the load current exceeds the I_{OCP} threshold the unit will initially hold the current constant at the OCP level by reducing the output voltage. However, should the load be increased further and the output voltage fall below approximately 70% of it's set point, the unit will enter hiccup mode. The output will remain off for a certain period and then attempt to restart. The module remains in this state until the over load condition is removed, at which point the module returns to normal operation.

Note that hiccup mode current limit schemes can cause startup issues in certain circumstances where load currents plus any capacitive charging currents exceed the current limit. For reliable designs the user should ensure the worst case measured startup current does not exceed 90% of the rated current.

Reverse Current Protection (RCP)

NEVO Dual output modules use synchronous rectification in the output stages to achieve high efficiency and as a result the outputs can both source and sink current. The sink current is internally limited to approximately -6% of the maximum rated current.

Dual output modules should never be directly connected to external power sources without some form of reverse current protection such as an external diode or controlled mosfet. If protection is not used, large reverse currents which will ultimately result in damage to the unit will occur, especially when the AC mains is disconnected.

Start up & Shut down

All outputs are designed to have a regulated monotonic start-up with a controlled rise time which is specified in the datasheet. The power good signal stays low until the voltage for both outputs is within the power good threshold range ($\approx 95\%$).

Dual outputs are designed to start into a pre-biased load without causing any discharge.

At shutdown the outputs enter a high impedance state. Where no external load is present it may take some time for the voltage to decay. When driving inductive loads, care must be taken to limit the voltage at the output terminals so as to prevent damage to the unit.

Synchronisation

All dual output modules in the same chassis are synchronised. The typical operating frequency is 260kHz and seriesed units will not produce beat frequencies.

Ripple and Noise

The ripple and noise figures stated in the datasheet are defined based on a standard measuring method. To obtain the same results the same test setup must be used and care must be taken to eliminate any parasitic noise pickup. The diagram below shows details of the setup and also sources of noise pickup.

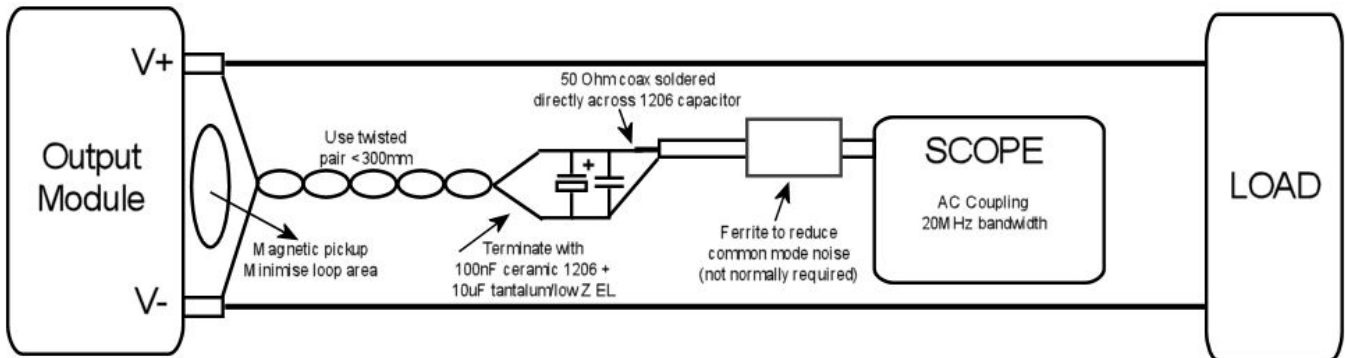

Over Temperature Protection (OTP)

Each output module is protected against excessive temperatures. In the event of the internal temperatures exceeding safe levels the entire unit may be latched off. To resume operation of the unit, disconnect the AC input voltage for 2 minutes, ensure external ambient temperatures are within specifications and then reconnect the AC input voltage. Note that no warning is given on the AC_OK signal for faults of this type.

Transient response

The NEVO Dual output modules have been especially designed to have high reliability and to achieve this, electrolytic capacitors have been minimised or eliminated from the design. As a result, the typical output capacitance of the module is relatively low and high dynamic load transients can cause relatively high voltage deviations at the output. Where this causes an application issue, external low impedance electrolytic capacitance may be added to improve the transient response.

However, for Dual output modules the maximum recommended external capacitance is 680 μF . Exceeding this value may cause startup issues.

Parallel operation

NEVO Dual Output modules cannot be paralleled. Paralleling dual output modules may result in damage.

Seriesed operation

NEVO Dual Output modules can be seriesed.

Temperature Derating

For Dual Output modules the temperature derating factor applies to output current not output power.

Remote sensing

Remote sensing is available on all Dual output modules and can be used to compensate for a small voltage drop in the main power leads between the power supply and the load. To implement remote sensing connect the positive sense pin [S+, connector J5.1 (Top) or J5.3 (Bottom)] to the positive side of the remote load and the negative sense pin [S-, connector J5.2 (Top) or J5.5 (Bottom)] to the negative side of the remote load. The voltage will be regulated at the points where the sense cables are connected.

In systems where remote sensing is not used, the output voltage at the power terminals will be slightly higher than that at the sense terminals. This voltage difference is termed, open sense offset and occurs due to internal bias currents in the sensing circuit. Factory set units are set with the sense cables connected unless otherwise specified.

Isolation

Each output channel in a NEVO Dual output module is fully isolated. Each output is rated for 250 volts maximum between each output terminal and chassis ground. Exceeding this voltage may damage the unit.

Audible Noise

The following series of plots characterise the audible noise from the NEVO+1200 power supply over various conditions. These plots can be used to estimate the actual audible noise for any application.

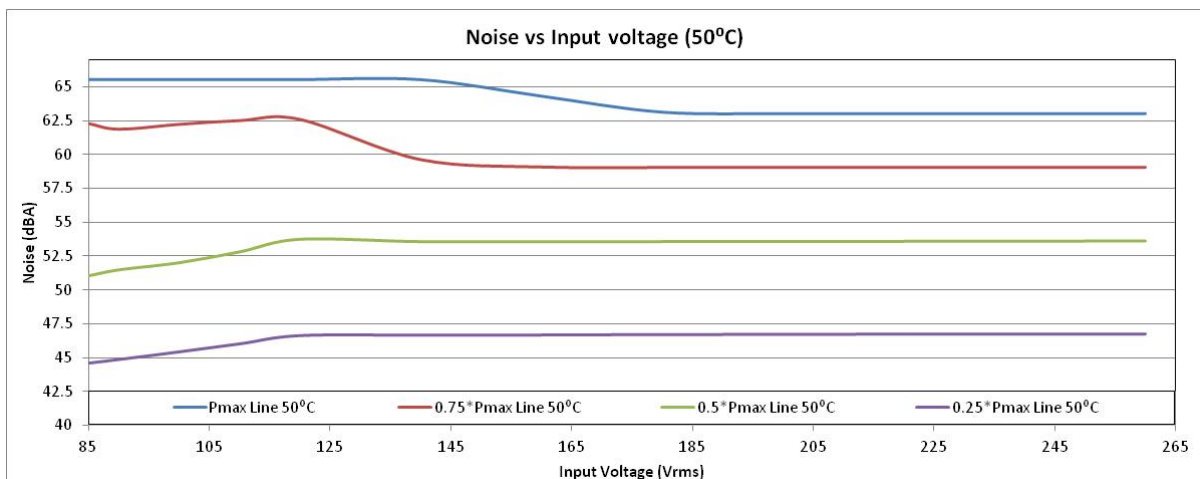
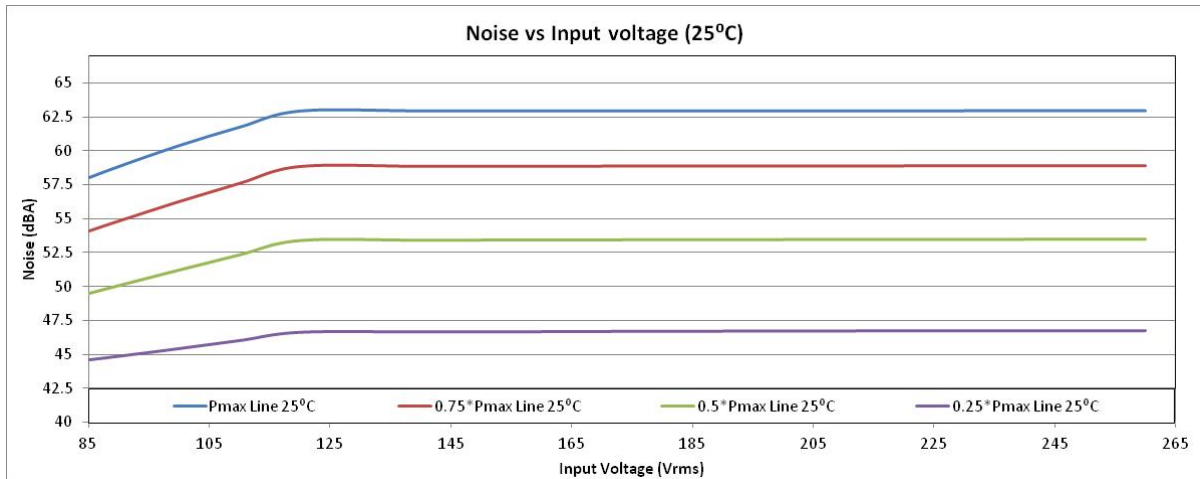
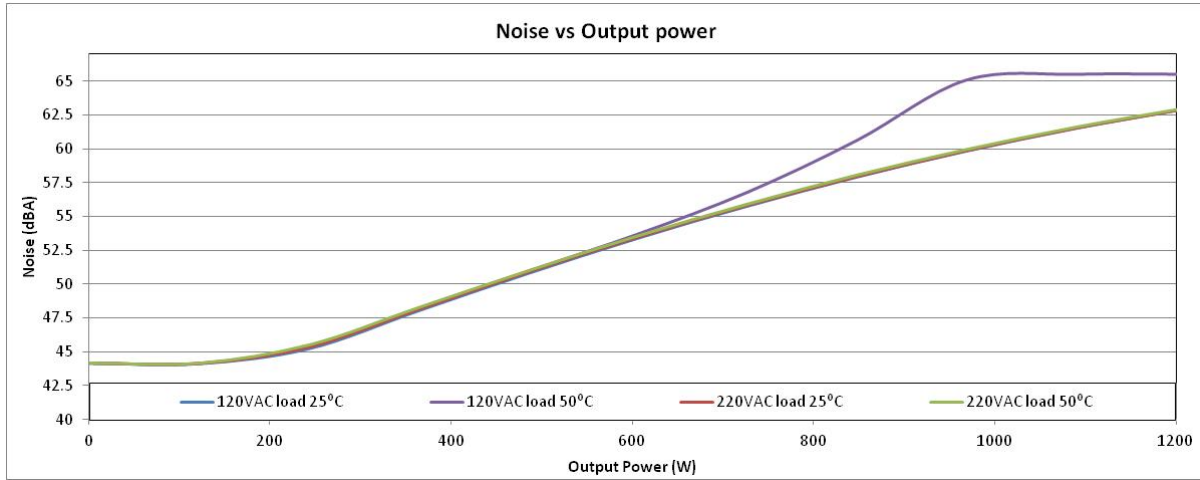

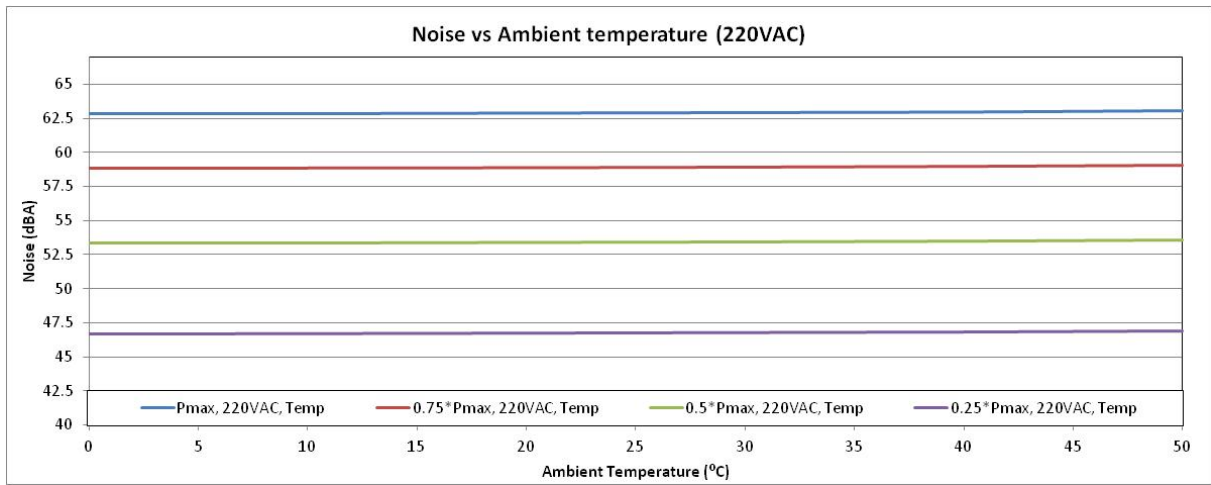
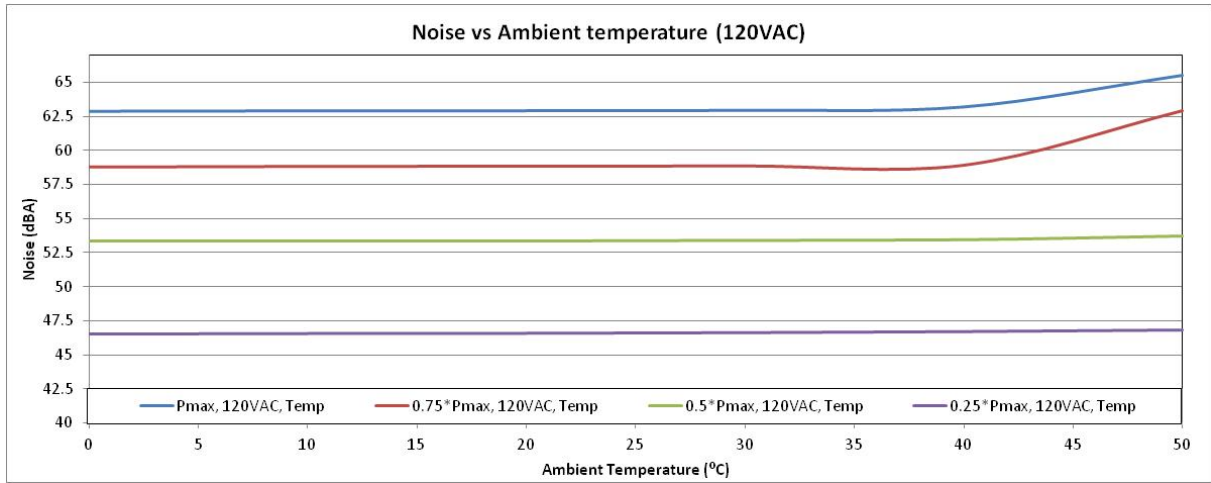

Mechanical Dimensions and Mounting

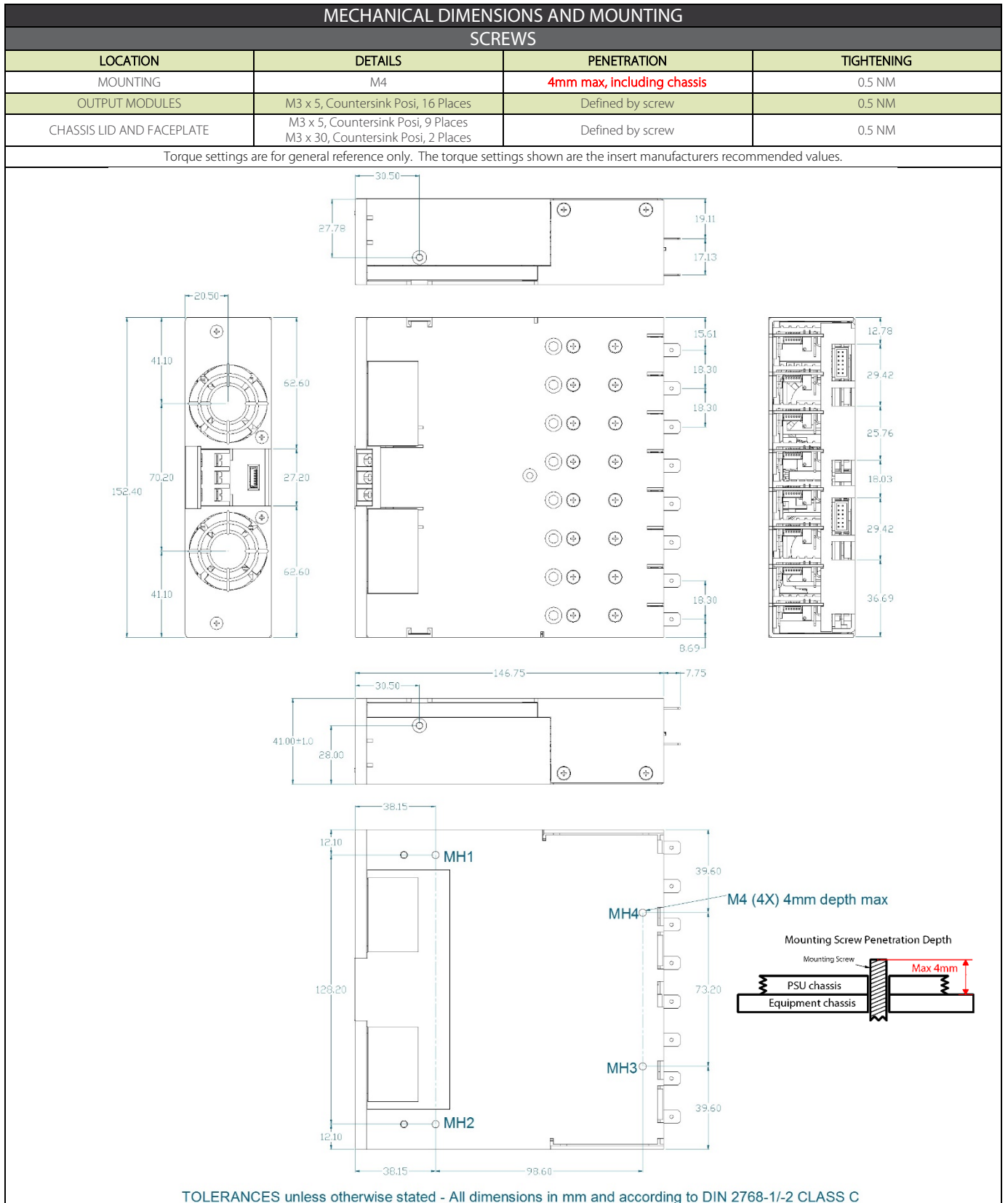

Connectors

CONNECTORS

PIN Assignments		
J1		
Circuit	Details	
1	Live	
2	Earth	
3	Neutral	
J2a/b		
Circuit	Details	
1	Power Good	Slot A and E
2	Inhibit	Slot B and F
3	Power Good	Slot C and G
4	Inhibit	Slot D and H
5	Power Good	
6	Inhibit	
7	Power Good	
8	Inhibit	
9	Global Inhibit	
10	AC OK	
11	+5V 1A Bias Supply	
12	COM	
J6		
1	Common	
2	+5V 500mA Bias Supply	
3	Shut Down	
4	Reserved	
5	Reserved	
6	Reserved	

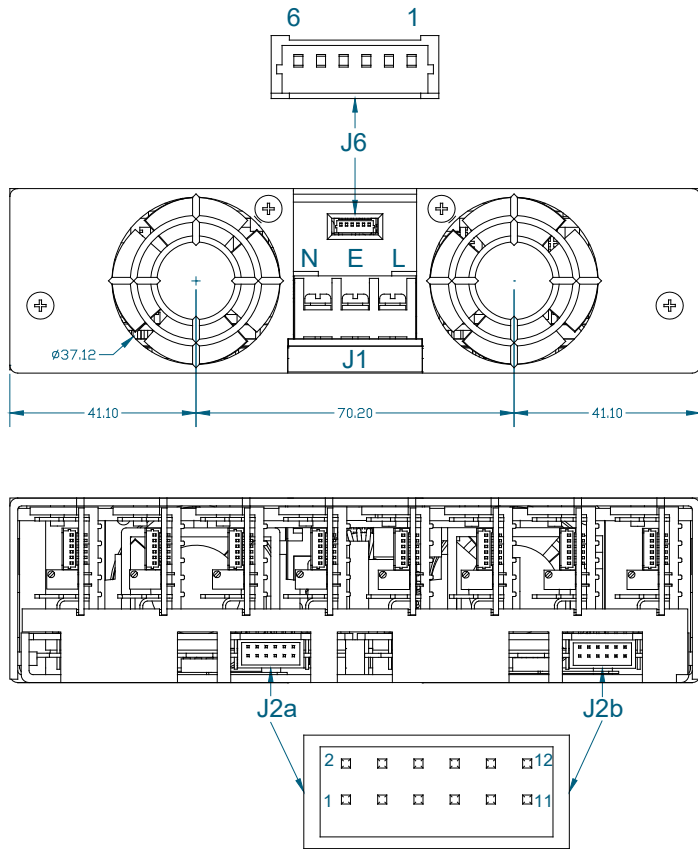

REF	DETAILS	MANUFACTURER	HOUSING	TERMINAL
J1	MAINS INPUT: 3 Pin, Barrier, 6-32 Steel Screws, 0.8NM or 7IN LB Torque Cable 14-18AWG, 300V, 16A, 105°C, use appropriately rated fork or ring terminal.	MOLEX		
J2a/b	GLOBAL SIGNALS: 12 Pin, 2mm, with Friction Lock, 24-30 AWG	MOLEX	511101251	503948051
J6	INPUT BIAS: OUTPUT SIGNALS: 6 Pin, 1.25mm, with Friction lock, 28-32 AWG	MOLEX	510210600	500588000

Notes

1. Direct equivalents may be used for any connector parts.
2. All cables must be rated 105°C min, equivalent to UL1015

Configuring Your NEVO Product

The NEVO+1200 power supply is designed to be used as part of an end-system in a restricted environment and therefore should only be accessible to qualified and trained personnel. Persons attempting to configure a unit must have the necessary knowledge and training before doing so. Incorrect configuration may cause damage to the power supply and may affect the warranty of the power supply.

Output power modules may be added, replaced or moved by strictly following the sequence of operations described below. Please contact Vox Power or your distributor for assistance in configuring your power supply. Never assume, always ask.

STEP 1:

If the power supply is being configured for the first time remove the front end unit from the packaging and continue to step two. If the power supply is being reconfigured always adhere to the rest of this step. Ensure the mains power connection is switched off and then disconnect the main power connection from the power supply. Take care as the outer surface of the power supply may be hot. Allow the power supply to cool down sufficiently before handling it. Remove all other connections from the power supply. If the power supply is mounted onto a base plate remove the screws attaching it to the base plate so that the power supply can be easily handled during configuration.

Once all the connections are removed let the power supply stand for 3 minutes before attempting to configure or re-configure the power supply.

STEP 2:

Removing the screws: At the fan side there are 2 longer and 2 shorter screws, remove only the two longer screws. These are the two screws above and either side of the input connector. Do not remove the two screws on the outer edges of the faceplate. Proceed to remove the 6 screws on the sides (3 each side) and 17 on the top (2 for each slot and 1 in the centre just below the product label). The lid can now be removed. Ensure that all the output modules are loose from the lid before removing the lid. For new front end configurations there will not be any output modules in place. Where ever blanking plates are inserted top screws do not need removing.

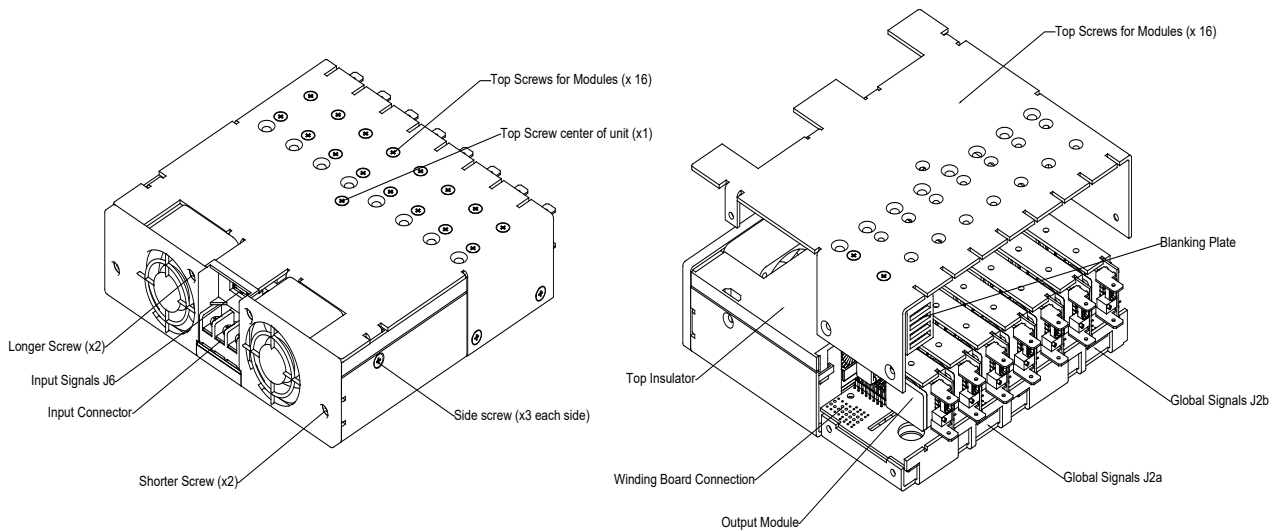

WARNING!

Do not remove the Top Insulator

STEP3:

Once the lid is removed modules can be inserted, removed and replaced as required. For single slot modules, a single 15 pin header on the output module plugs directly into the connector on the input module PCB. For dual slot modules, a dual 15 pin header on the output module plugs directly into two connectors on the input module PCB. Note that there are no placement restrictions for dual slot modules. To insert the output modules, carefully align the required input and output connectors, then push down firmly ensuring not to cause any mechanical damage to the output module connector. Do not remove the plastic cover on the front-end of the unit.

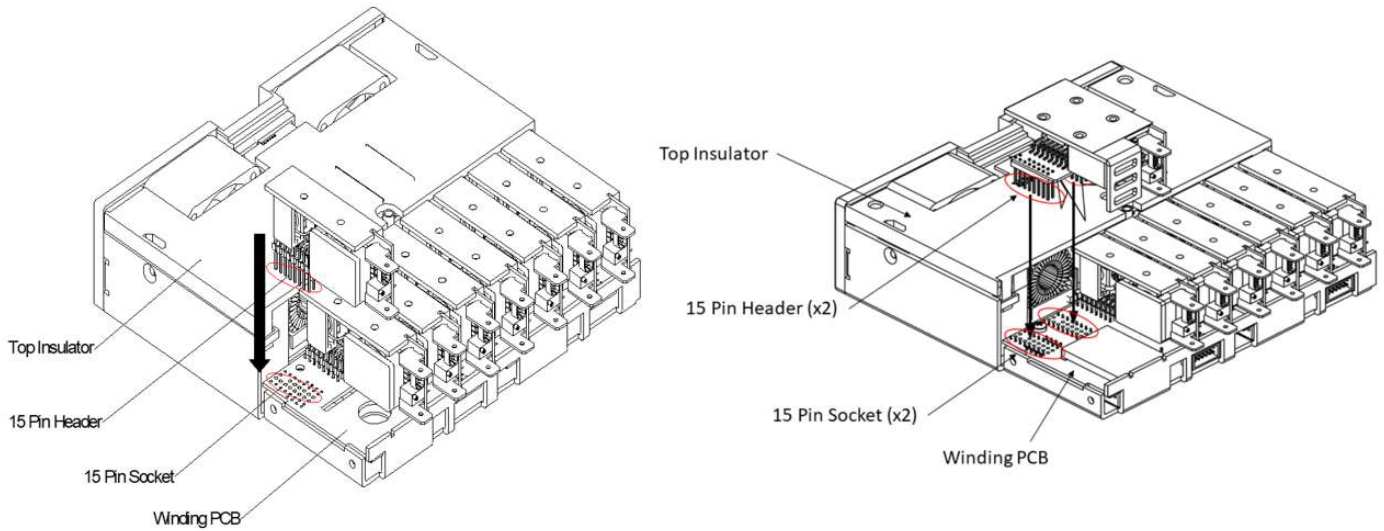

STEP 4:

Once the output modules are inserted and the new configuration is complete the lid can be closed again. A blanking plate must always be used whenever a slot does not contain an output module. It is easier to attach blanking plates to the lid before closing it. Ensure the top plastic cover insulator is in place before closing the lid again. When closing the lid ensure that each output module slots properly into its corresponding slot in the lid. Insert all the screws and tighten to 0.50 Nm. Do not over tighten.

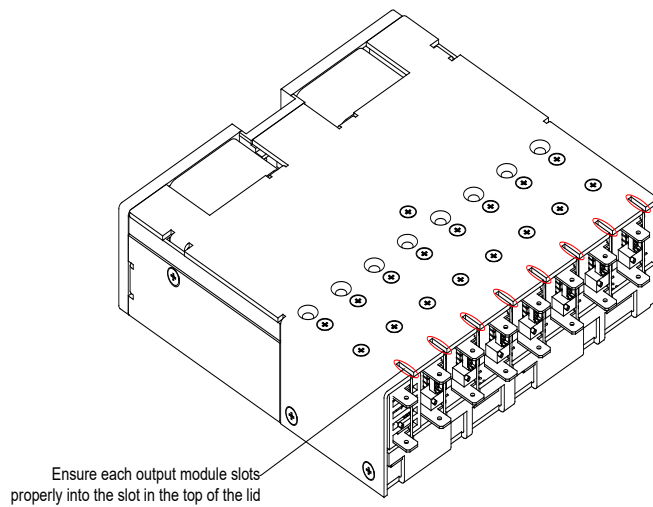

STEP 5:

Reconnect the power cable and apply power to ensure all the output modules are working by checking that the green LED light on each output module comes on. Always measure the output voltage of each output to ensure it is adjusted to your requirements. Measure the output voltage between the positive and negative output terminals or at the sense terminals on J5 of each output module. Consult the datasheet for the pin out of J5. The output voltage of each output module can be adjusted by adjusting the potentiometer above the negative output terminal. Turning the potentiometer clockwise adjusts the output voltage upwards and anti-clockwise adjusts the output voltage downwards.

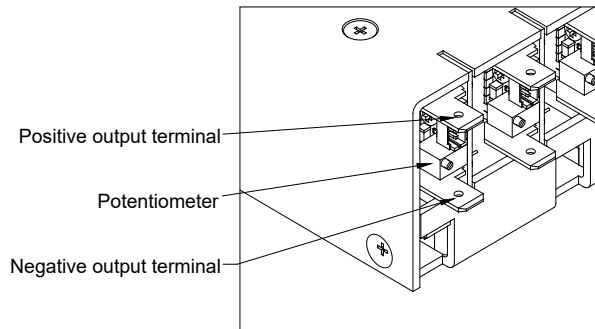

For dual output modules there are two potentiometers, one for each output. To adjust the output voltage of the top output, measure the voltage between the top positive and top negative terminals and adjust the top output potentiometer to the desired output voltage. To adjust the output voltage of the bottom output, measure the voltage between the bottom positive and bottom negative terminals and adjust the bottom output potentiometer to the desired output voltage. Turning the potentiometer clockwise adjusts the output voltage upwards and anti-clockwise adjusts the output voltage downwards.

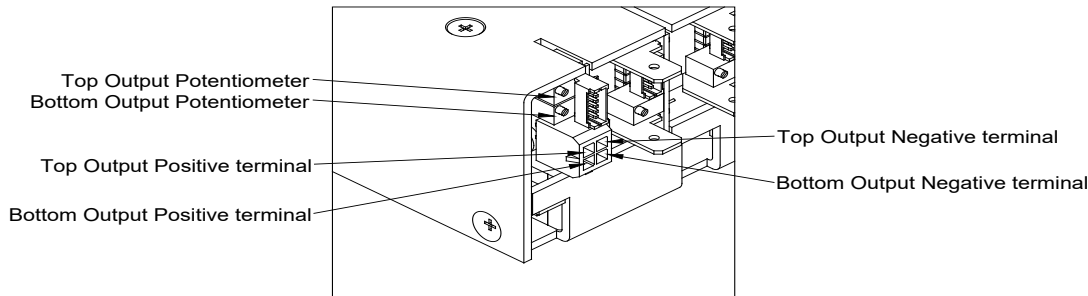

When all output voltages are adjusted to the desired voltages, switch off the supply power and attach all other cables. The unit is now ready for use. If the power supply is configured for the first time or if it has to be moved to a different location prior to operation, switch off the supply power and remove the mains power cable from the power supply. Ensure the configured unit is safely packaged into the original packaging or into appropriate alternative packaging before moving it to its operational location.

TROUBLESHOOTING:

In the unlikely event that one or more of the green LED lights on the output modules stay off once the supply power is switched on, it may be that there is a problem with the power supply. Please contact Vox Power for assistance.

WARNING!

Leave the unit to stand for a minimum of 3 minutes after removing all power and other connections from the unit before attempting to configure or re-configure the power supply.

WARNING!

Always remove the power before handling the unit. During operation the external surface of the unit can become hot. Leave to stand for 10 minutes to allow the unit to cool down before handling the unit.

WARNING!

Dangerous voltages are present within the power supply. Covers may only be removed by qualified personnel when the power supply has been disconnected from the mains supply voltage for more than 3 minutes. Covers must be replaced and all screws secured properly before reconnecting to the mains voltage.

WARNING!

Do not apply power to the power supply before replacing the lid and securing all the screws.

Series Connected Output Modules

NEVO output modules of the same type can be series connected to achieve higher output voltages. Below is an illustration of how to series connect two output modules in Slot A and B with the series link shown separately. For example, if there is a requirement for 80Vdc it can be achieved by connecting two OP4 outputs in series. By repeating steps 1 to 5 above insert two OP4 output modules, one each in Slot A and B (or any other slot as the configuration requires). Adjust each of the OP4 output modules to 40Vdc as per step 5. Connect the two OP4 output modules in series using the series link. The series link connects the negative output of the OP4 output module in Slot A to the positive output of the OP4 output module in Slot B. Measure the output voltage between the positive output terminal of OP4 in Slot A and the negative output terminal of OP4 in Slot B. You should measure 80Vdc. For more information on how to connect two or more modules in series please see the 'Series Connected Outputs' section in the NEVO Series Installation Notes.

Install series links as shown with tab pointing way from unit.
Orientate the series link during installation such that the vertical segment is in line with the output PCB as shown below (Green hatch lines - link, red line - centre line of Output PCB).

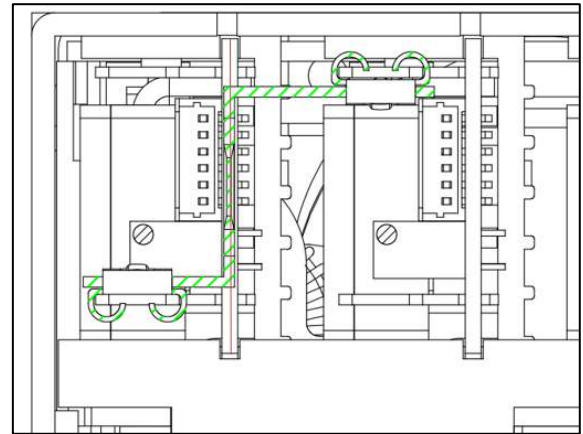
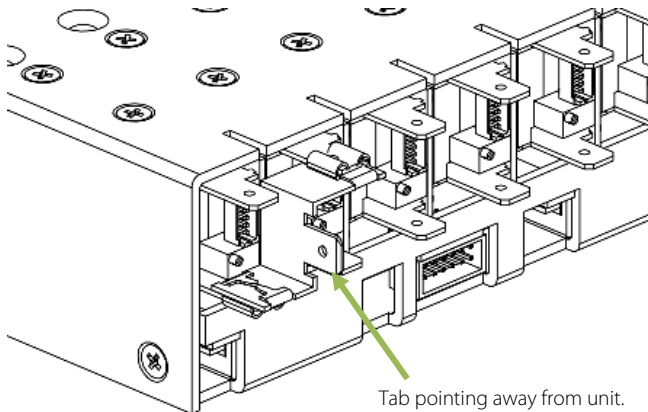

WARNING!

Energy and voltage hazards may arise when individual modules are series connected. When safe energy and voltage levels are exceeded ensure that an appropriate warning label is affixed to the power supply in a manner that service personnel will always notice it. See the Safety section for more details.

Paralleled Connected Output Modules

NEVO single output modules of the same type can be paralleled in any number within the same chassis to achieve higher output currents. For best performance, the output voltages of each paralleled module should be adjusted to the same set point or as close as possible. For more accurate current sharing pin 4 of the J5 connectors of each modules need to be connected together. To achieve this connection Vox Power has a range of current sharing links available. Please discuss your requirements with your distributor or with Vox Power before ordering your unit. For more information on how to connect two or more modules in parallel please see the 'Paralleled Outputs' section in the NEVO Series Installation Notes following this section.

Below is an illustration of a mechanical connection to parallel connect four modules in Slots A-D. Connector sets to connect 2, 3 and 4 modules in parallel are available from Vox Power.

- Install by sliding the smaller part of the parallel link over the top connectors and the larger part of the parallel link over the bottom connectors to ensure access to the bottom screw as shown.
- Ensure the screw head is pointing up as shown.
- Install so that the terminal clips in the links are closest to the unit as shown.

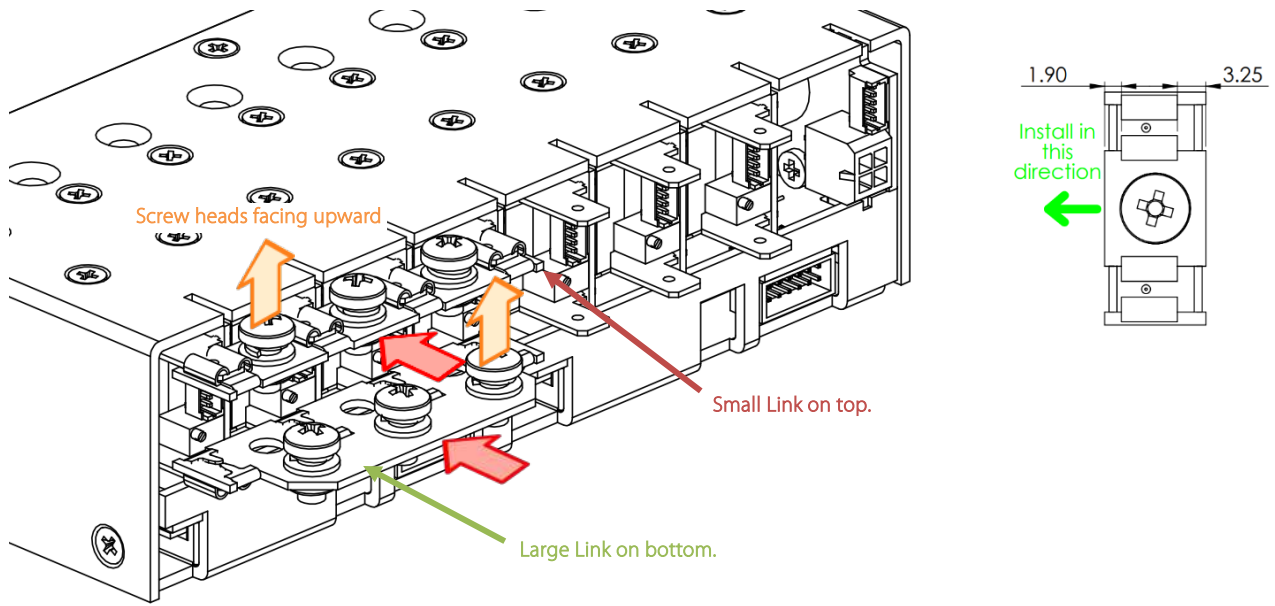

For the NEVO+1200 unit a set of jumper links are also available. By using these jumper links up to eight modules can be connected in parallel. Connect jumper link as shown below and ensure the screws are properly tightened.

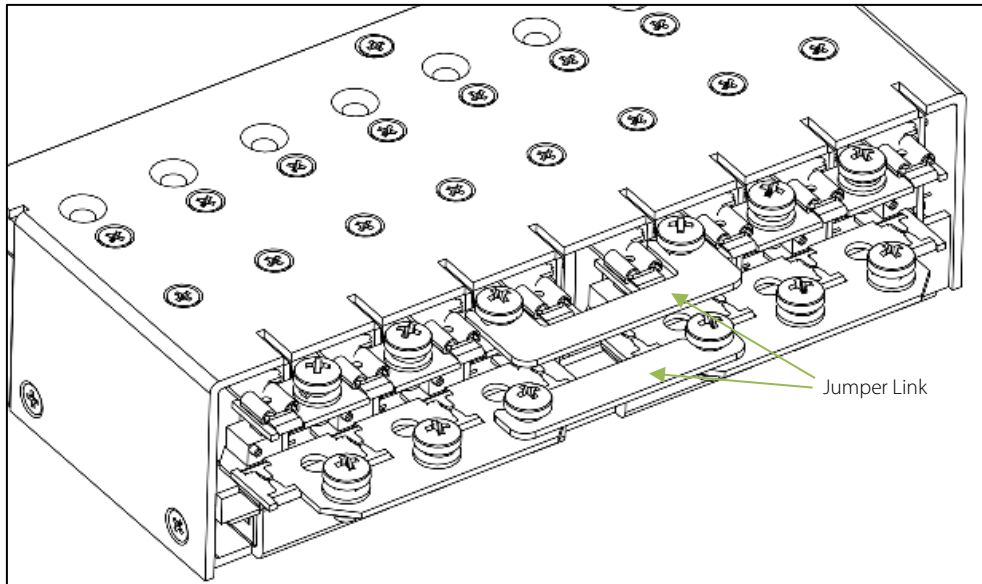

WARNING!

Energy and voltage hazards may arise when individual modules are paralleled. When safe energy and voltage levels are exceeded ensure that an appropriate warning label is affixed to the power supply in a manner that service personnel will always notice it. See the Safety section for more details.

Example Configurations

Example 1: Configuration a unit for the first time – NEVO+1200S-11112340

The below illustration take steps 1 to 5 above into consideration.

Remove the NEVO+1200S Front End from the packaging. At this point there are no output modules and no blanking plates (OP0) installed. Remove the screws as shown below. At the fan side remove only the two longer screws which are above and either side of the input connector. Do not remove the two shorter screws which are located on the outer edges of the faceplate. Next remove the 6 screws (3 each side) at the side of the unit and 1 screw at the top of the unit. Remove the lid.

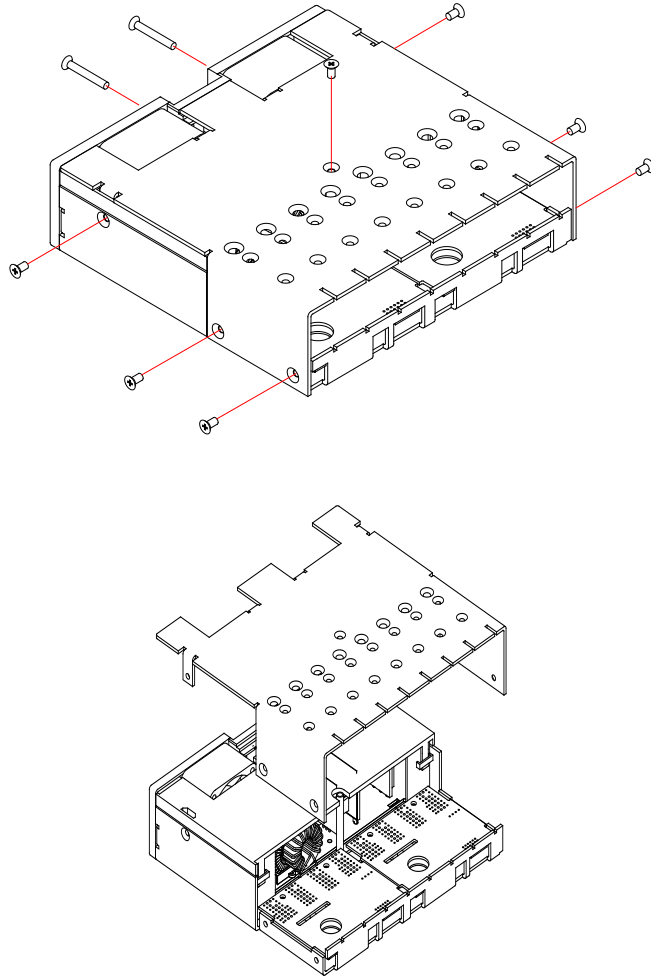

Insert the modules as the configuration requires – 1 OP1 module into Slot A, Slot B, Slot C and Slot D; 1 OP2 module into Slot E; 1 OP3 module in Slot E and 1 OP4 module into Slot F.

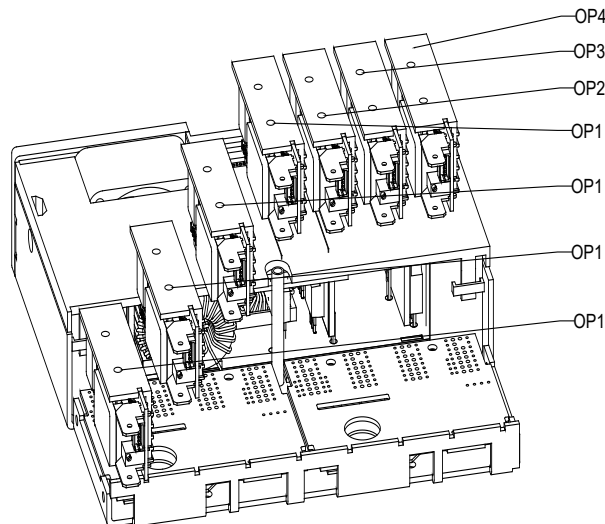

The Blanking Plate is inserted directly into the lid as shown below and should be done before putting the chassis lid back onto the chassis base.

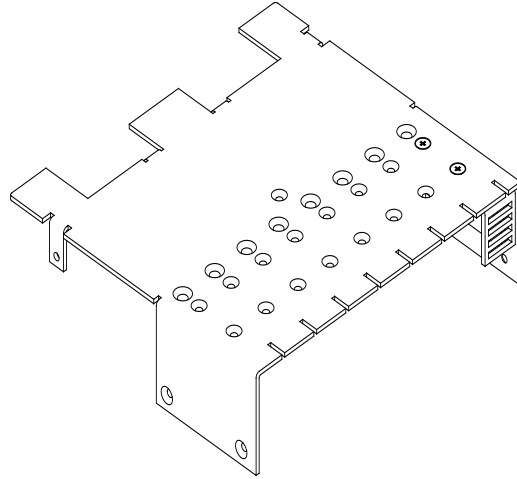

Place the lid back onto the chassis base. Ensure the PCB of each Output Module fits into the corresponding slot on the chassis lid. Secure all the screws.

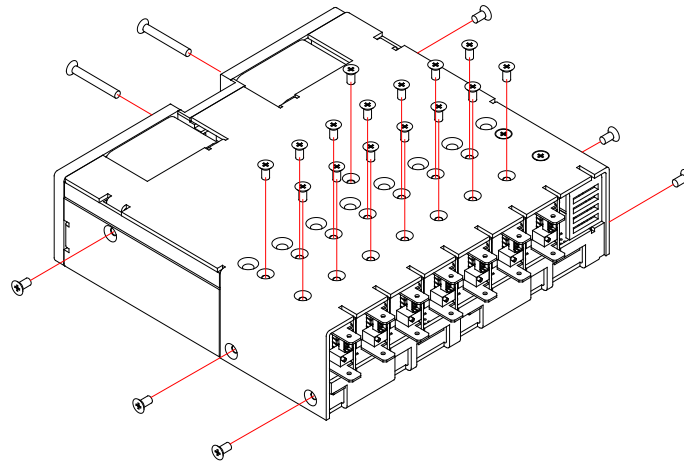

Once all the screws are fully secured attach the power cord and switch on the main supply voltage. Ensure that the Green LED light on each Output Module comes on. As per step 5, measure the output voltage of each output module and adjust to the desired voltage by adjusting the potentiometer below the positive output terminal (top terminal).

Example 2: Configuration of a paralleled output – NEVO+1200S-11112340 – With the four OP1's in parallel to create one 3.30Vdc output capable of up to 100A.

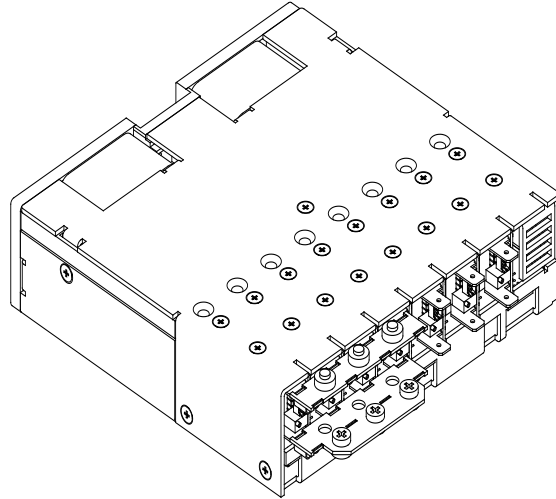

Complete the configuration as described in Example 1 above. In order to create a single output capable of delivering up to 100A the four OP1 modules in Slot A to Slot D should be connected in parallel. Connect the negative parallel link between the negative output terminals of the four OP1 modules. Do not connect the positive link as this stage. As per step 5 above measure the output voltage of the OP1 output module in Slot A and adjust the output voltage to 3.3Vdc. Repeat for the OP1 modules in Slot B, Slot C and Slot D. For best performance the output voltages of the four OP1 modules need to be adjusted as close as possible to one another.

If current sharing is required, attach a current share link (available from Vox Power) to the relevant J5 connectors.

Connect the positive link between the positive output terminals of the four OP1 modules. Always apply force only in a direction parallel with the output terminals to prevent any accidental bending of the output terminals. Make sure both links are properly pushed in.

Safety

The NEVO unit has been designed to comply with the Low Voltage Directive DIR 2014/35/EU (LVD), the EMC Directive DIR 2014/30/EC and DIR 2011/65/EU regarding the restriction of certain hazardous substances and is CE marked to show its compliance.

When correctly installed (per the installation manual) in a limited access environment the NEVO+1200S/SL/M/ML comply with the requirements of IEC/EN/UL/CSA 62368-1, IEC/EN/UL/CSA 60950-1 2nd Editions and IEC/EN/UL/CSA 60601 3rd Edition respectively.

The power supply should not be operated close to combustible materials or atmosphere.

Care should be taken to ensure liquid or metal shavings do not enter the power supply as this can cause a fire hazard.

The power supply does not contain any user serviceable parts and should be returned to Vox Power for repair.

Approval Limitations (NORTH AMERICA)

When this product is used with 180VAC–253VAC mains where no neutral is present, connect the two live wires to L (Live) and N (Neutral) on the input connector.

WARNING!

Series connected modules with combined voltages exceeding 60 volts are not considered SELV. Paralleled and/or series modules with combined energy ratings greater than 240 VA may cause energy hazards. The equipment manufacturer must provide additional and adequate protection to service and technical personnel.

Always remove the power before handling the unit. During operation the external surface of the unit can become hot. Leave to stand for 10 minutes to allow the unit to cool down before handling the unit.

Dangerous voltages are present within the power supply. Covers may only be removed by qualified personnel when the power supply has been disconnected from the mains supply voltage for more than 2 minutes. Covers must be replaced and all screws secured properly before reconnecting to the mains voltage.

Parameter	Details	Min	Max	Units
Isolation voltage	Input to Output. Do not perform test on assembled unit⁽¹⁾		4000	Vac
	Input to Chassis		1500	Vac
	Output to Chassis		250	Vdc
	Output to Output		250	Vdc
Isolation clearance	Primary to Secondary (Reinforced)	7		mm
	Primary to Chassis (Basic)	2.5		mm
Isolation creepage	Primary to Secondary (Reinforced)	12		mm
	Primary to Chassis (Basic)	4		mm
Leakage current	Medical: 265 Vac, 63 Hz, 25°C		300	µA
	Standard: 265 Vac, 63Hz, 25°C		1500	
Agency Approvals	cURus, Demko, CB Certificate			
Standards	IEC/EN/UL/CSA 62368-1 (2 nd Edition); IEC/EN/UL/CSA 60950-1 (2 nd Edition); IEC/EN/CSA 60601-1; (3 rd Edition) CE Mark: DIR 2014/35/EU (LVD), the EMC Directive DIR 2014/30/EU and DIR 2011/65/EU			
Agency File Numbers	UL : E316486			
Notes	1. Testing an assembled unit to 4000VAC may cause damage. Please refer to application note (APN-002) on Vox Power website or contact Vox Power representative.			

EMC Compliance

To support compliance of the final system design with the EMC directive 89/336/EEC, the NEVO PSU has been designed and tested to the following standards.

Parameter	Standard	Level
Emissions		
Radiated Emissions	EN55011, EN55022, FCC	A (See Note)
Conducted Emissions	EN55011, EN55022, FCC	B
Harmonic Distorsion	EN61000-3-2	Compliant
Flicker and Fluctuation	EN61000-3-3	Compliant
Immunity		
Electrostatic Discharge	EN61000-4-2 (15 kV air, 8 kV contact)	4
Radiated RFI	EN61000-4-3 (10 V/m)	3
Fast Transient Burst	EN61000-4-4 (4 kV)	4
Input Line Surges	EN61000-4-5 (1 kV L-N, 2 kV L-E)	3
Conducted RFI	EN61000-4-6 (10 V)	4
Power Magnetic field	EN61000-4-8 (10 A/m)	3
Voltage Dips& Interruptions	EN61000-4-11 (EN55024)	Compliant

Note: To meet Class B radiated emissions the end user should add ferrites to IP and OP cables. Consult Vox Power for details.

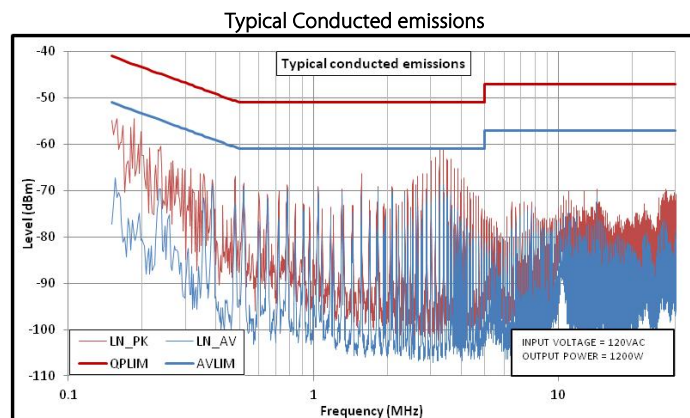

For radiated and conducted emissions, compliance of the final system relies on proper installation of the PSU component. The installation guidelines detailed below should be followed.

Installation Guidelines for EMC

NEVO units should be mounted within a metal enclosure using the mounting fixtures provided. If the application enclosure is not metal then a metal ground plate should be used to mount both the power supply and the load.

Decoupling the loads to the chassis or ground plate with suitably rated 100nF capacitors can assist in reducing emissions.

Both input and output cables should be fixed as close as possible to the ground plate or metal enclosure. Also, input and output cables should be separated as much as possible.

Output power and sense cables should be twisted pairs and routed parallel to each other. Do not twist sense and power cables together.

All cables lengths and loop areas should be minimised.

Where cables must enter or exit the enclosure, good high frequency 100nF decoupling capacitors of sufficient voltage rating should be connected to the cables as close to the entry/exit point as possible.

For further details or assistance contact Vox Power.

Reliability

The NEVO+1200 series has undergone extensive testing, including HALT and Environmental testing. Reliability data is collected on an ongoing basis. Please contact Vox Power or your distributor for the most up to date reliability data.