

REVISIONS					
P	LTR	DESCRIPTION	DATE	DMN	APVD
C2		REVISED PER ECR-20-004142	29JUN2020	BDA	SW

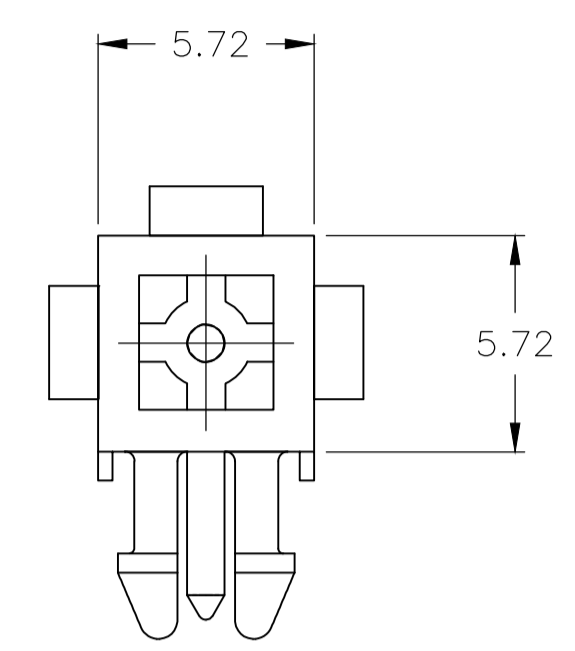

- PINS TO COMPLY WITH AMP SOLDERABILITY SPEC 109-11-3.
- MATES WITH PLUG P/N 172164-1.
- COORDINATE DIMENSION APPLIES FROM CENTER OF ACTUAL FEATURE.
- RECOMMENDED FOR EDGE MOUNTING.
- 0.00381 MIN MATTE TIN LEAD OVER 0.00127 MIN NICKEL ENTIRE LENGTH OF PIN.
- 0.00076 MIN GOLD PLATE IN THE LOCALIZED PLATE AREA, 0.00381 MIN MATTE TIN LEAD IN THE LOCALIZED PLATE AREA, BOTH OVER 0.00127 MIN NICKEL.
- 0.00381 MIN MATTE TIN PLATE OVER 0.00127 MIN NICKEL.
- 0.00076 MIN GOLD PLATE IN THE LOCALIZED GOLD PLATE AREA, 0.00381 MIN MATTE TIN IN THE LOCALIZED TIN PLATE AREA, BOTH OVER 0.00127 MIN NICKEL.
- SUPERSEDED BY 1-794374-1

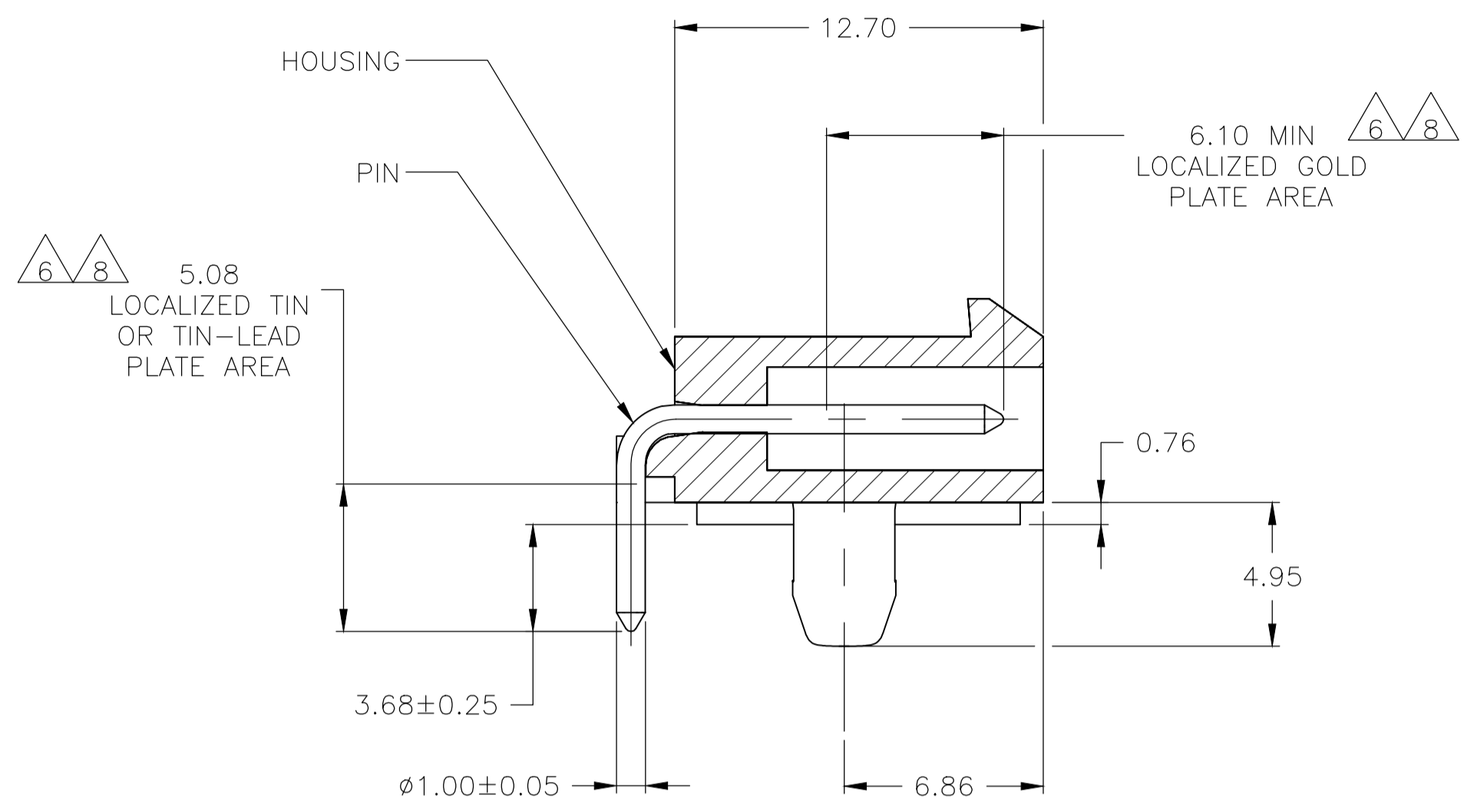
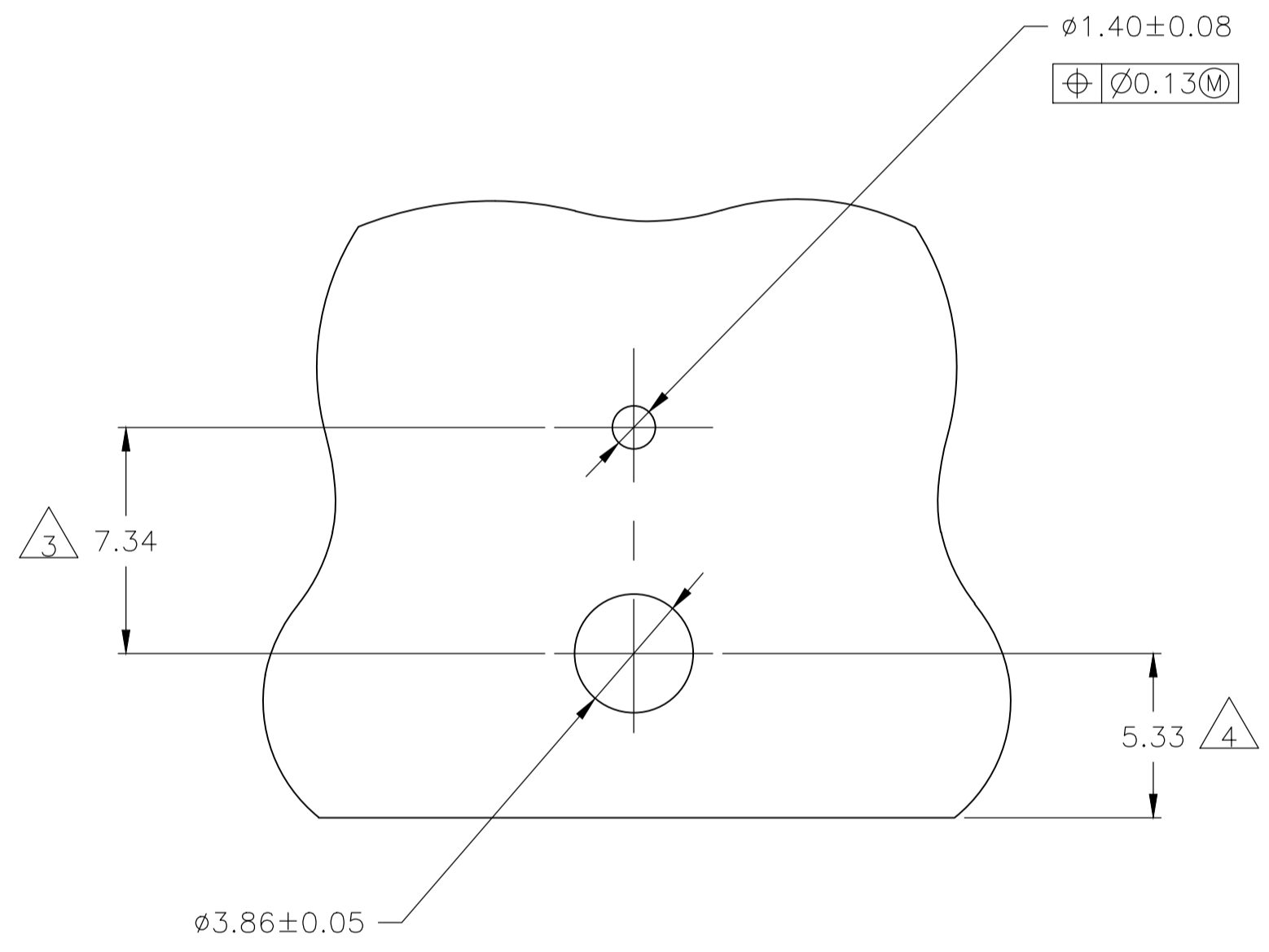

RECOMMENDED MOUNTING HOLE PATTERN FOR 1.57 THICK P.C. BOARD

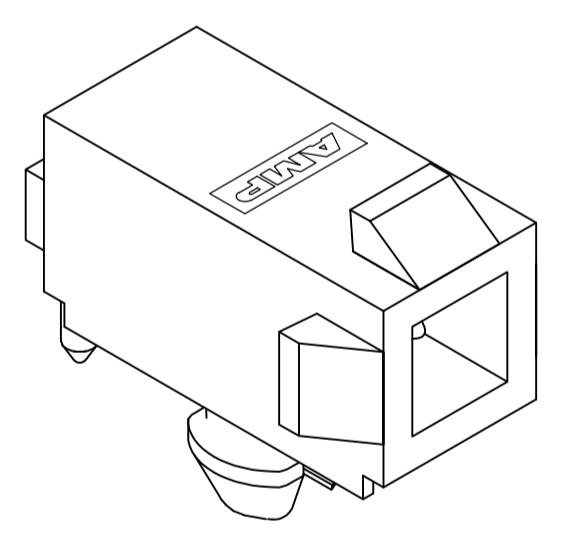

3-DIMENSIONAL MODEL

MM	IN	MM	IN	MM	IN	MM	IN
0.13	.005	3.68	.145	6.10	.240	-	-
0.08	.003	1.57	.062	5.72	.225	-	-
0.05	.002	1.40	.055	5.33	.210	-	-
0.00381	.000150	1.00	.039	5.08	.200	12.70	.500
0.00127	.000050	0.76	.030	4.95	.195	7.34	.289
0.00076	.000030	0.25	.010	3.86	.152	6.86	.270

CONVERSION TABLE

	MATERIAL	FINISH	MATERIAL	COLOR	PART NO
	BRASS	8	NYLON, UL94V-0	WHITE	1-794374-1
OBSOLETE	BRASS	7	NYLON, UL94V-0	WHITE	1-794374-0
	BRASS	6	NYLON, UL94V-0	WHITE	794374-2
OBSOLETE	BRASS	5	NYLON, UL94V-0	WHITE	794374-1

THIS DRAWING IS A CONTROLLED DOCUMENT.		DIN K WHITAKER 17APR97		TE Connectivity	
DIMENSIONS: mm		TOLERANCES UNLESS OTHERWISE SPECIFIED:		NAME: HEADER ASSEMBLY, RIGHT ANGLE, SINGLE CIRCUIT, MINI UNIVERSAL MATE-N-LOK(TM)	
0. PLC ± -		1. PLC ± -		SIZE: A1	
1. PLC ± 0.13		2. PLC ± -		SCALE: 5:1	
3. PLC ± -		3. PLC ± -		SHEET: 1 OF 1	
4. PLC ± -		4. PLC ± -		REV: C2	
ANGLES: ± 0°30'		WEIGHT: 0.000000		CUSTOMER DRAWING	
MATERIAL: SEE TABLE		FINISH: SEE TABLE		DRAWING NO: 00779C=794374	