

DO NOT SCALE FROM THIS PRINT

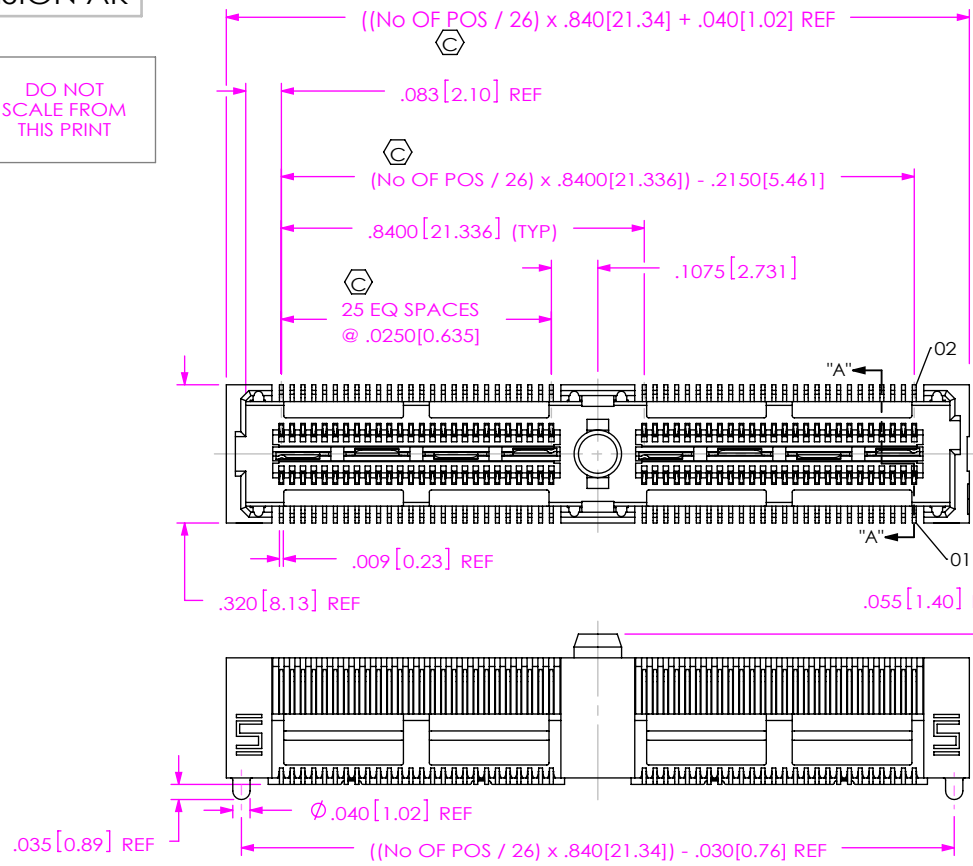

NO OF POSITIONS
-026, -052, -078, -104, *-130 (PER ROW)

LEAD STYLE
-04.25 (SEE NOTE 9)
-06.25

PLATING SPECIFICATION
-L: 10µ" SELECTIVE GOLD IN CONTACT AREA, MATTE TIN ON TAIL (SEE TABLE 7) (AVAILABLE ON -04.25 LEAD STYLE ONLY)
-H: 30µ" GOLD IN CONTACT AREA, 3µ" GOLD ON TAIL (SEE TABLE 7) (AVAILABLE ON -04.25 LEAD STYLE ONLY)
-S: 30µ" SELECTIVE GOLD IN CONTACT AREA, MATTE TIN ON TAIL (SEE TABLE 7) (AVAILABLE ON -06.25 LEAD STYLE ONLY)
-SL: 10µ" SELECTIVE GOLD IN CONTACT AREA, MATTE TIN ON TAIL (SEE TABLE 7) (AVAILABLE ON -06.25 LEAD STYLE ONLY)

ROW SPECIFICATION
-D: DOUBLE

OPTION
-A: ALIGNMENT PIN
-GP: GUIDE HOLE (SEE FIG 2, SHEET 2) (AVAILABLE ON -04.25 LEAD STYLE ONLY)

PACKAGING
BLANK: TRAY (SEE NOTES 8 & 10)
-TR: TAPE & REEL (SEE NOTES 10 & 11)
-FR: FULL REEL QTY TAPE & REEL (SEE NOTES 10 & 11)
(-TR & -FR PACKAGING AVAILABLE FOR: -026 & -052 POS IN -04.25 LEAD STYLE, -026 THRU -078 POS IN -06.25 LEAD STYLE WITH NO END OPTIONS, -078 POS WITH NO END OPTIONS) (-104 & -130 POS NOT AVAILABLE IN -TR & FR)

PICK & PLACE OPTION
-P: PICK & PLACE PAD (USE PPP-51, SEE FIG 4, SHT 2)

END OPTIONS
-PC4: 4 POWER POS PER END (.062" THICK BOARD) (SEE FIG 3, SHEET 3)
-PC8: 8 POWER POS PER END (.062" THICK BOARD) (SEE FIG 3, SHEET 3)
-PT4: 4 POWER POS PER END (.093" THICK BOARD) (SEE FIG 3, SHEET 3)
-PT8: 8 POWER POS PER END (.093" THICK BOARD) (SEE FIG 3, SHEET 3)
-RF1: 1 RF POS PER END (SEE FIG 5, SHEET 4)
-RF2: 2 RF POS PER END (SEE FIG 6, SHEET 4)
-RT1: 1 RT POS PER END (SEE FIG 7, SHEET 5)

* = NOT TOOLED

(-PXX & -RFX NOT AVAILABLE IN COMBINATION WITH -A OR -GP) (END OPTION APPLIES TO BOTH ENDS, COMBINATIONS ARE NOT AVAILABLE)
(-PXX & -RFX AVAILABLE IN POS -026, -052, & -078 ONLY)
(-RT1 AVAILABLE IN -026, -052, -078, & -104 POS WITH -A OPTION ONLY)
(-PXX, -RFX, & -RT1 AVAILABLE ON -04.25 LEAD STYLE ONLY)

LEAD STYLE	"M"	"N"	QFS BODY	CONTACT	GROUND PLANE	MATED TO QMS-XX.XX	MATED HEIGHT
-04.25	.293	.278	QFSS-26-04.25-D-XX-X	C-181-04.25-XX	T-1G20-04.25-L	QMS-05.75	.394[10.00] REF
						QMS-06.75	.433[11.00] REF
						QMS-09.75	.551[14.00] REF
-06.25	.371	.356	QFSS-26-06.25-D-XX-X	C-223-06.25-XX	T-1G28-06.25-L	QMS-05.75	.472[12.00] REF
						QMS-06.75	.512[13.00] REF
						QMS-09.75	.630[16.00] REF

No OF POSITIONS	No OF BANKS	COPLANARITY
-026 THRU -078	1 THRU 3	.004[.10]
-104 AND -130	4 AND 5	.006[.15]

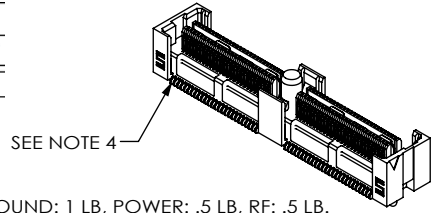

- NOTES:
- ⊙ REPRESENTS A CRITICAL DIMENSION.
 - MAXIMUM BURR ALLOWANCE: .0015[0.038]
 - MINIMUM PUSHOUT FORCE: SIGNAL: .5 LB, GROUND: 1 LB, POWER: .5 LB, RF: .5 LB.
 - ALL CONTACTS ON THE -04.25 LEAD STYLE WILL BE SHEARED.
 - MAXIMUM VARIANCE OF .002[0.05].
 - DIMENSION APPLIES TO CONTACTS & GROUND PLANE.
 - GROUND PLANE PRESS HEIGHT MUST BE .003[0.08] LESS THAN THE MAXIMUM HEIGHT OR .001[0.03] GREATER THAN THE MINIMUM HEIGHT OF THE TERMINAL.
 - TRAYS ARE STANDARD PACKAGING.
 - LEADSTYLE -01 MAY BE SUBSTITUTED IN PART CALLOUT FOR -04.25 FOR EXISTING CUSTOMERS ONLY.
 - ORDERS WILL BE PACKAGED ACCORDING TO THE SAMTEC PACKAGING EFFICIENCY STANDARDS (SPES) FOUND ON WWW.SAMTEC.COM.
 - ATTACH LABEL TO EACH REEL.

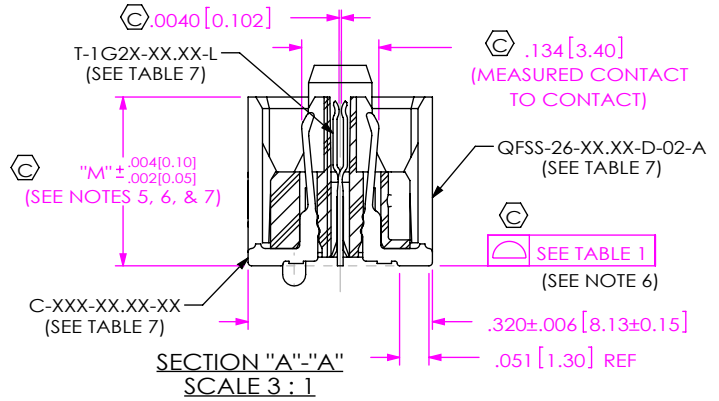



FIG 1
QFS-052-04.25-X-D-A SHOWN

UNLESS OTHERWISE SPECIFIED, DIMENSIONS ARE IN INCHES.	PROPRIETARY NOTE THIS DOCUMENT CONTAINS CONFIDENTIAL AND PROPRIETARY INFORMATION AND ALL DESIGN, MANUFACTURING, REPRODUCTION, USE, PATENT RIGHTS AND SALES RIGHTS ARE EXPRESSLY RESERVED BY SAMTEC, INC. THIS DOCUMENT SHALL NOT BE DISCLOSED, IN WHOLE OR PART, TO ANY UNAUTHORIZED PERSON OR ENTITY NOR REPRODUCED, TRANSFERRED OR INCORPORATED IN ANY OTHER PROJECT IN ANY MANNER WITHOUT THE EXPRESS WRITTEN CONSENT OF SAMTEC, INC.	 520 PARK EAST BLVD, NEW ALBANY, IN 47150 PHONE: 812-944-6733 FAX: 812-948-5047 e-Mail: info@SAMTEC.com code: 55322
TOLERANCES ARE: DECIMALS ANGLES .XX: ±.01[0.3] 2° .XXX: ±.005[0.13] .XXXX: ±.0020[0.051]	MATERIAL: DO NOT SCALE DRAWING INSULATOR: LCP, COLOR: BLACK CONTACTS & GROUND PLANE: PHOS BRONZE	
SHEET SCALE: 2.25:1 DESCRIPTION: .635mm DOUBLE ROW TERMINAL STRIP DWG. NO. QFS-XXX-XX.XX-XX-D-XX-XXX-X-XX BY: E.L.S. 6/09/2003 SHEET 1 OF 5		

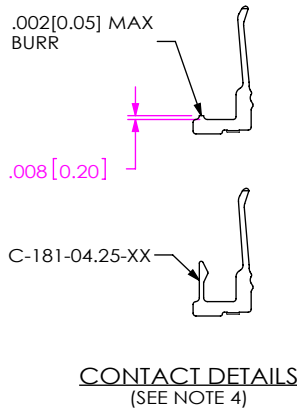
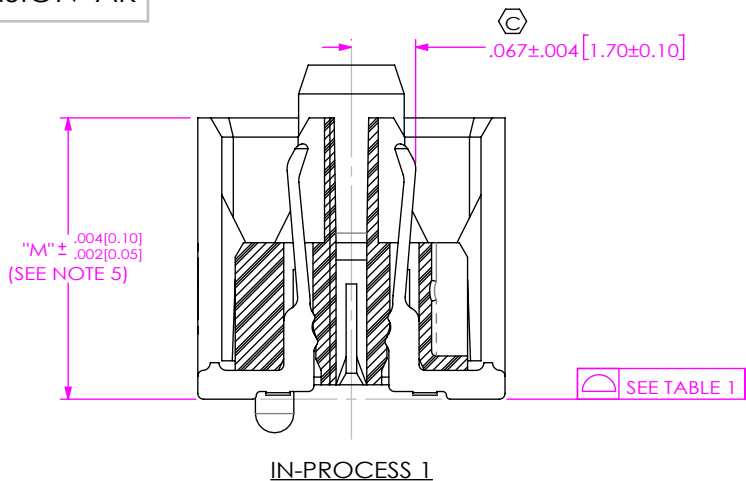

TABLE 2

ASSEMBLY	"A"	"B"
QFS-026-04.25-X-D-A-GP	1.050[26.67]	1.330[33.78]
QFS-052-04.25-X-D-A-GP	1.890[48.00]	2.170[55.12]
QFS-078-04.25-X-D-A-GP	2.730[69.34]	3.010[76.45]
QFS-104-04.25-X-D-A-GP	3.570[90.68]	3.850[97.79]
QFS-130-04.25-X-D-A-GP	4.410[112.01]	4.690[119.13]

FIG 2
 -GP: GUIDE HOLE OPTION
 (QFS-052-04.25-X-D-A-GP SHOWN)
 (NOT AVAILABLE WITH -PXX OPTIONS)
 (AVAILABLE ON -04.25 LEAD STYLE ONLY)

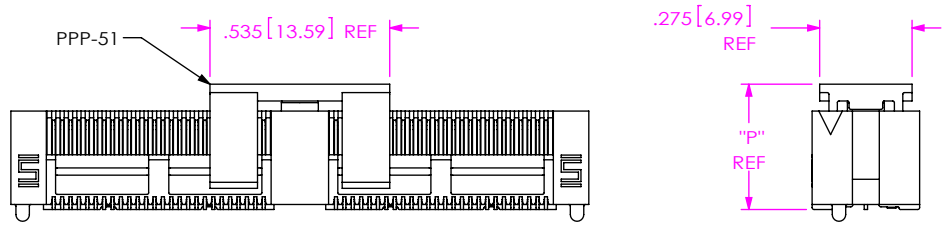
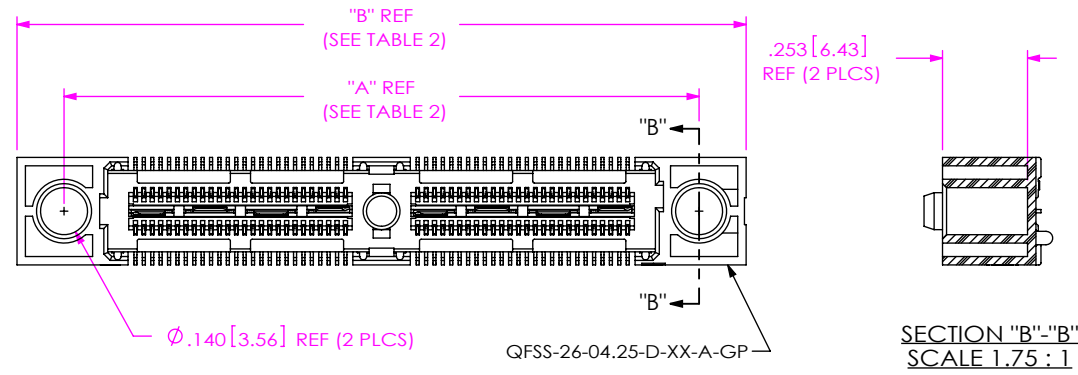
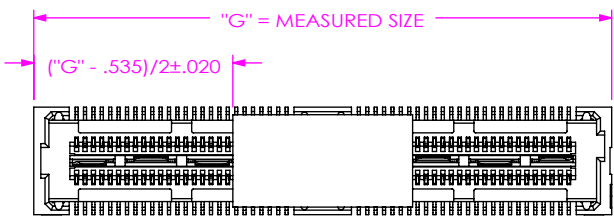

TABLE 8

LEAD STYLE	"P"
-04.25	.373[9.47]
-06.25	.451[11.46]

FIG 4
 -P: PICK & PLACE PAD OPTION

PROPRIETARY NOTE
 THIS DOCUMENT CONTAINS CONFIDENTIAL AND PROPRIETARY INFORMATION AND ALL DESIGN, MANUFACTURING, REPRODUCTION, USE, PATENT RIGHTS AND SALES RIGHTS ARE EXPRESSLY RESERVED BY SAMTEC, INC. THIS DOCUMENT SHALL NOT BE DISCLOSED, IN WHOLE OR PART, TO ANY UNAUTHORIZED PERSON OR ENTITY NOR REPRODUCED, TRANSFERRED OR INCORPORATED IN ANY OTHER PROJECT IN ANY MANNER WITHOUT THE EXPRESS WRITTEN CONSENT OF SAMTEC, INC.

DO NOT SCALE DRAWING
 SHEET SCALE: 2.5:1

520 PARK EAST BLVD, NEW ALBANY, IN 47150
 PHONE: 812-944-6733 FAX: 812-948-5047
 e-Mail: info@SAMTEC.com code: 55322

DESCRIPTION:
 .635mm DOUBLE ROW TERMINAL STRIP

DWG. NO.
QFS-XXX-XX.XX-XX-D-XX-XXX-X-XX

BY: E.L.S. 6/09/2003 SHEET 2 OF 5

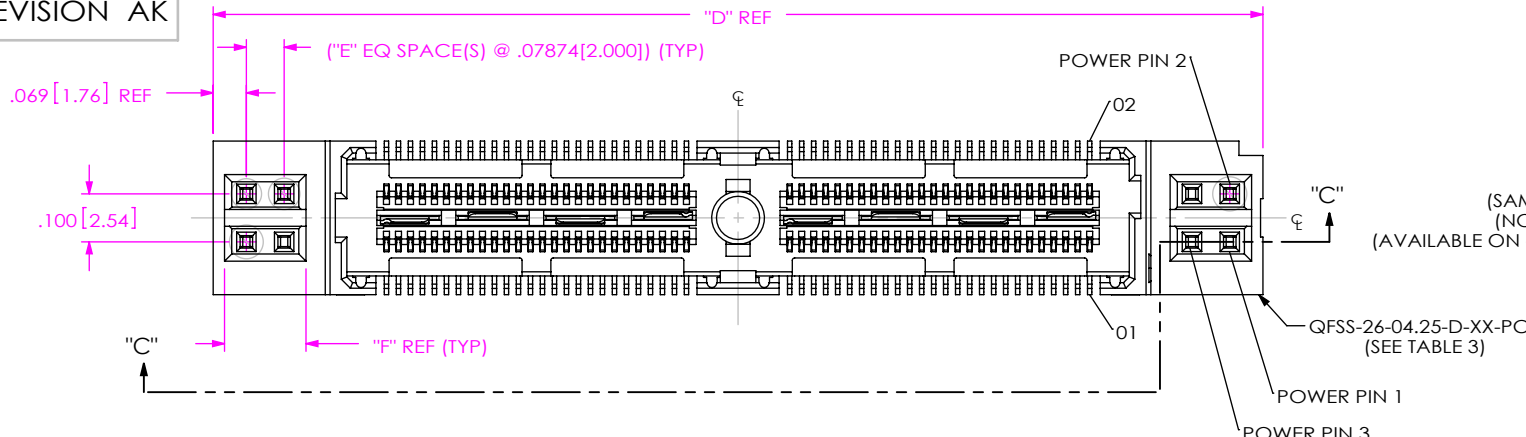

FIG 3
 POWER COMBO OPTIONS
 (QFS-052-04.25-X-D-PC4 SHOWN)
 (SAME AS FIG 1, UNLESS OTHERWISE STATED)
 (NOT AVAILABLE WITH -A OR -GP OPTION)
 (AVAILABLE ON -04.25 LEAD STYLE ONLY, POS -026, -052, -078 ONLY)

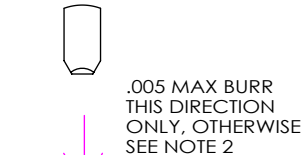
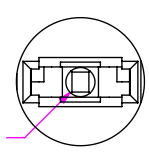
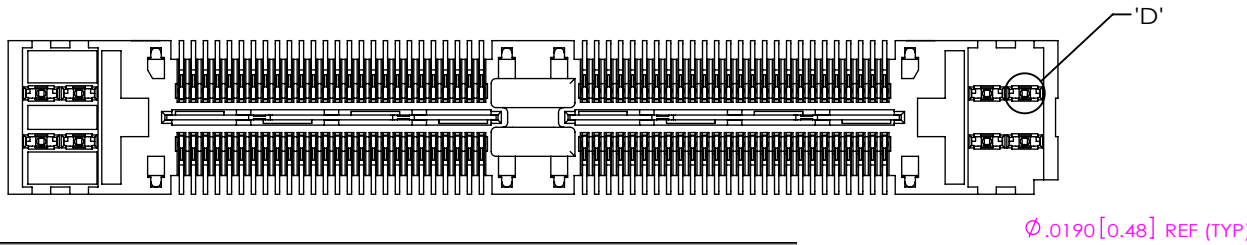
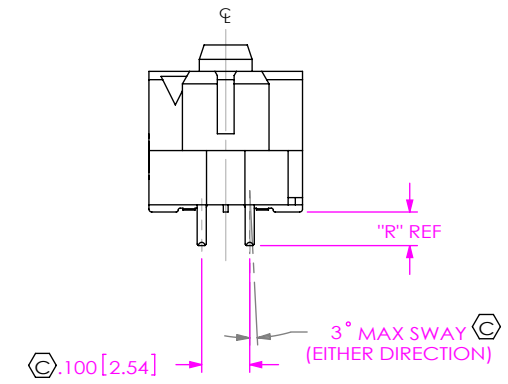
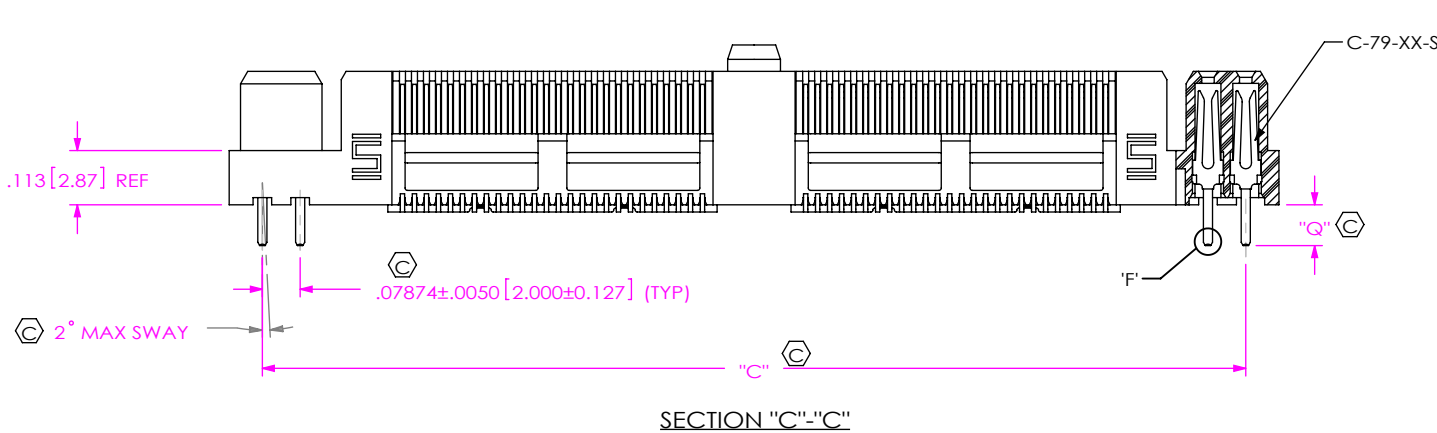

TABLE 9

POWER OPTION	CONTACT	"Q"	"R"
PC4/PC8	C-79-06-S	.085[2.16]	.070[1.78]
PT4/PT8	C-79-09-S	.125[3.18]	.110[2.79]

TABLE 3

ASSEMBLY	QFSS-26-04.25-D-XX-PCX	"C"	"D"	"E"	"F"
QFS-026-04.25-X-D-PX4	QFSS-26-04.25-D-01-PC4	1.209[30.70]	1.347[34.21]	1	.170[4.31]
QFS-026-04.25-X-D-PX8	QFSS-26-04.25-D-01-PC8	1.524[38.70]	1.662[42.21]	3	.327[8.31]
QFS-052-04.25-X-D-PX4	QFSS-26-04.25-D-02-PC4	2.049[52.04]	2.187[55.55]	1	.170[4.31]
QFS-052-04.25-X-D-PX8	QFSS-26-04.25-D-02-PC8	2.364[60.04]	2.502[63.55]	3	.327[8.31]
QFS-078-04.25-X-D-PX4	QFSS-26-04.25-D-03-PC4	2.889[73.37]	3.027[76.89]	1	.170[4.31]
QFS-078-04.25-X-D-PX8	QFSS-26-04.25-D-03-PC8	3.204[81.37]	3.342[84.89]	3	.327[8.31]

PROPRIETARY NOTE
 THIS DOCUMENT CONTAINS CONFIDENTIAL AND PROPRIETARY INFORMATION AND ALL DESIGN, MANUFACTURING, REPRODUCTION, USE, PATENT RIGHTS AND SALES RIGHTS ARE EXPRESSLY RESERVED BY SAMTEC, INC. THIS DOCUMENT SHALL NOT BE DISCLOSED, IN WHOLE OR PART, TO ANY UNAUTHORIZED PERSON OR ENTITY NOR REPRODUCED, TRANSFERRED OR INCORPORATED IN ANY OTHER PROJECT IN ANY MANNER WITHOUT THE EXPRESS WRITTEN CONSENT OF SAMTEC, INC.

DO NOT SCALE DRAWING
 SHEET SCALE: 2.5:1



520 PARK EAST BLVD, NEW ALBANY, IN 47150
 PHONE: 812-944-6733 FAX: 812-948-5047
 e-Mail: info@SAMTEC.com code: 55322

DESCRIPTION:
 .635mm DOUBLE ROW TERMINAL STRIP
 DWG. NO.
QFS-XXX-XX.XX-XX-D-XX-XXX-X-XX
 BY: E.L.S. 6/09/2003 SHEET 3 OF 5

TABLE 5			
ASSEMBLY	QFSS-26-04.25-D-XX-RFX	"H"	"J"
QFS-026-04.25-X-D-RF1	QFSS-26-04.25-D-01-RF1	1.403[35.64]	1.153[29.29]
QFS-026-04.25-X-D-RF2	QFSS-26-04.25-D-01-RF2	1.903[48.34]	1.653[41.99]
QFS-052-04.25-X-D-RF1	QFSS-26-04.25-D-02-RF1	2.243[56.97]	1.993[50.62]
QFS-052-04.25-X-D-RF2	QFSS-26-04.25-D-02-RF2	2.743[69.67]	2.493[63.32]
QFS-078-04.25-X-D-RF1	QFSS-26-04.25-D-03-RF1	3.083[78.31]	2.833[71.96]
QFS-078-04.25-X-D-RF2	QFSS-26-04.25-D-03-RF2	3.583[91.01]	3.333[84.66]

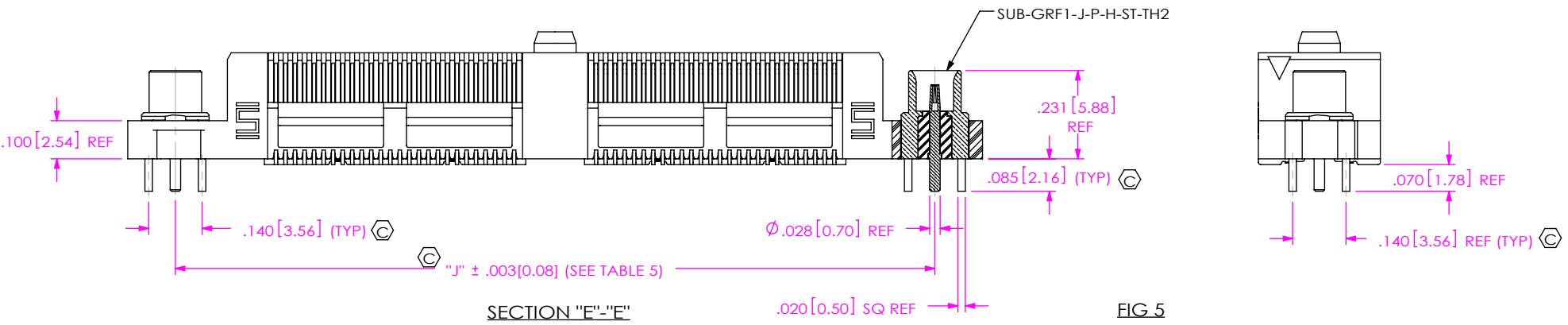
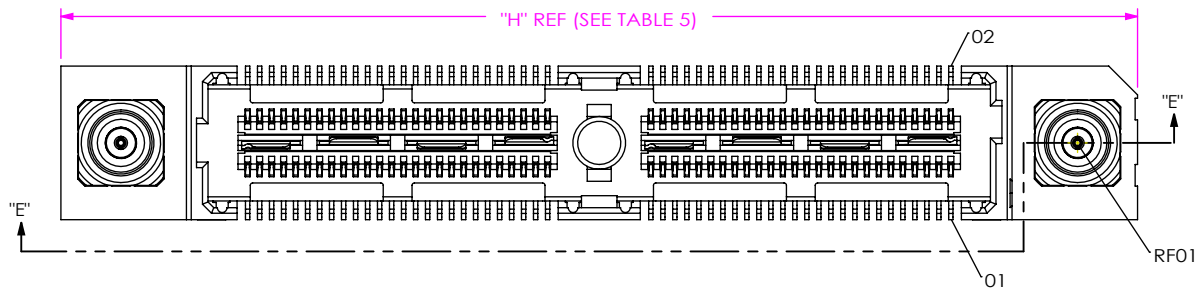

FIG 5
 -RF1 OPTION
 (QFS-052-04.25-X-D-RF1 SHOWN)
 (SAME AS FIG 3, UNLESS OTHERWISE STATED)
 (NOT AVAILABLE WITH -A OR -GP OPTIONS)
 (AVAILABLE ON -04.25 LEAD STYLE, POSITIONS -026, -052, & -078 ONLY)

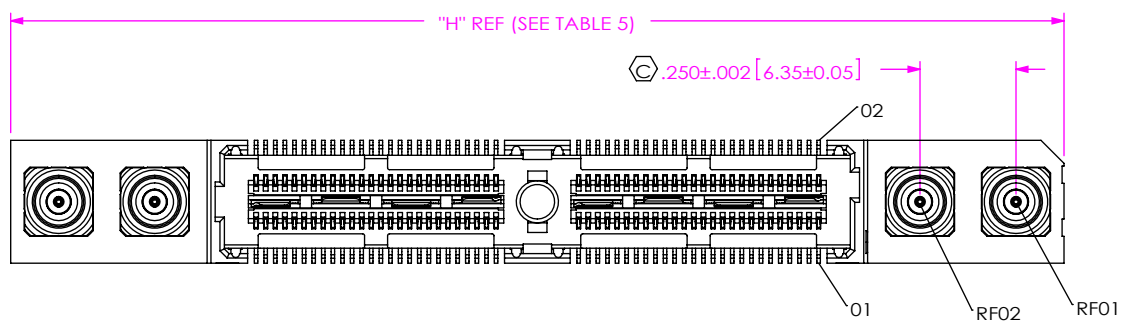
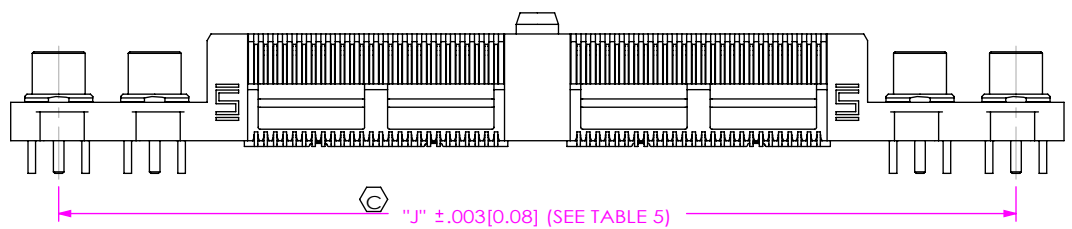

FIG 6
 -RF2 OPTION
 (QFS-052-04.25-X-D-RF2 SHOWN)
 (SAME AS FIG 5, UNLESS OTHERWISE STATED)
 (NOT AVAILABLE WITH -A OR -GP OPTIONS)
 (AVAILABLE ON -04.25 LEAD STYLE, POSITIONS -026, -052, & -078 ONLY)



PROPRIETARY NOTE
 THIS DOCUMENT CONTAINS CONFIDENTIAL AND PROPRIETARY INFORMATION AND ALL DESIGN, MANUFACTURING, REPRODUCTION, USE, PATENT RIGHTS AND SALES RIGHTS ARE EXPRESSLY RESERVED BY SAMTEC, INC. THIS DOCUMENT SHALL NOT BE DISCLOSED, IN WHOLE OR PART, TO ANY UNAUTHORIZED PERSON OR ENTITY NOR REPRODUCED, TRANSFERRED OR INCORPORATED IN ANY OTHER PROJECT IN ANY MANNER WITHOUT THE EXPRESS WRITTEN CONSENT OF SAMTEC, INC.

DO NOT SCALE DRAWING
 SHEET SCALE: 2.5:1

samtec
 520 PARK EAST BLVD, NEW ALBANY, IN 47150
 PHONE: 812-944-6733 FAX: 812-948-5047
 e-Mail: info@SAMTEC.com code: 55322

DESCRIPTION:
 .635mm DOUBLE ROW TERMINAL STRIP
 DWG. NO.
QFS-XXX-XX.XX-XX-D-XX-XXX-X-XX
 BY: E.L.S. 6/09/2003 SHEET 4 OF 5

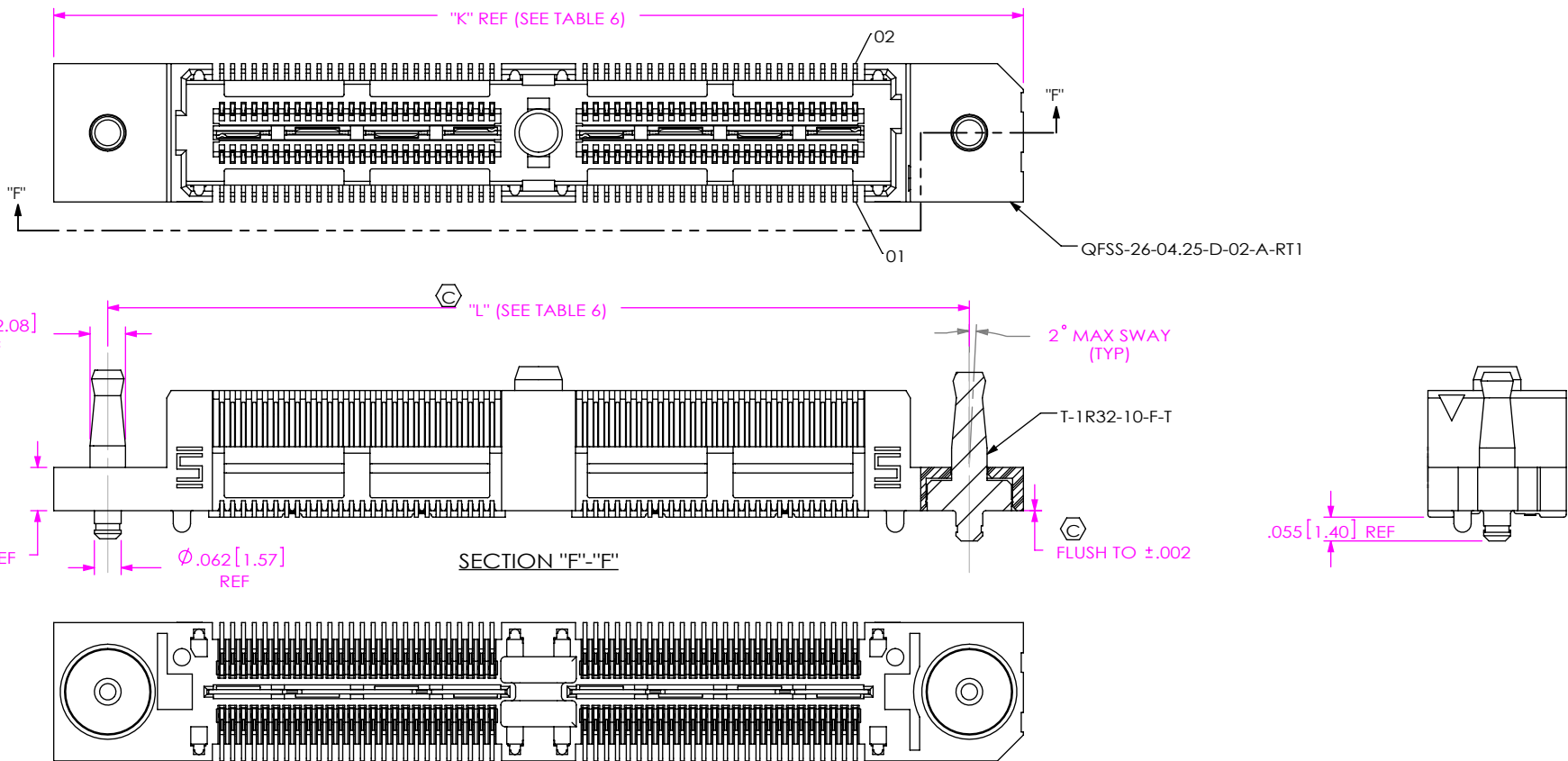

FIG 7
 -RT1 OPTION
 (QFS-052-04.25-X-D-A-RT1 SHOWN)
 (SAME AS FIG 3, UNLESS OTHERWISE STATED)
 (NOT AVAILABLE WITH -GP OR -RFX OPTIONS)
 (AVAILABLE ON -04.25 LEAD STYLE, POSITIONS -026, -052, -078, & -104 WITH -A OPTION ONLY)

ASSEMBLY	QFSS-26-04.25-D-XX-RTX	"K"	"L"
QFS-026-04.25-X-D-A-RT1	QFSS-26-04.25-D-01-A-RT1	1.403[35.64]	1.153[29.29]
QFS-052-04.25-X-D-A-RT1	QFSS-26-04.25-D-02-A-RT1	2.243[56.97]	1.993[50.62]
QFS-078-04.25-X-D-A-RT1	QFSS-26-04.25-D-03-A-RT1	3.083[28.31]	2.833[71.96]
QFS-104-04.25-X-D-A-RT1	QFSS-26-04.25-D-04-A-RT1	3.923[99.64]	3.673[93.29]

PROPRIETARY NOTE
 THIS DOCUMENT CONTAINS CONFIDENTIAL AND PROPRIETARY INFORMATION AND ALL DESIGN, MANUFACTURING, REPRODUCTION, USE, PATENT RIGHTS AND SALES RIGHTS ARE EXPRESSLY RESERVED BY SAMTEC, INC. THIS DOCUMENT SHALL NOT BE DISCLOSED, IN WHOLE OR PART, TO ANY UNAUTHORIZED PERSON OR ENTITY NOR REPRODUCED, TRANSFERRED OR INCORPORATED IN ANY OTHER PROJECT IN ANY MANNER WITHOUT THE EXPRESS WRITTEN CONSENT OF SAMTEC, INC.

DO NOT SCALE DRAWING

SHEET SCALE: 2.5:1



520 PARK EAST BLVD, NEW ALBANY, IN 47150
 PHONE: 812-944-6733 FAX: 812-948-5047
 e-Mail: info@SAMTEC.com code: 55322

DESCRIPTION:
 .635mm DOUBLE ROW TERMINAL STRIP

DWG. NO.
 QFS-XXX-XX.XX-XX-D-XX-XXX-X-XX

BY: E.L.S. 6/09/2003 SHEET 5 OF 5