

THIS IS A CONTROLLED DOCUMENT.

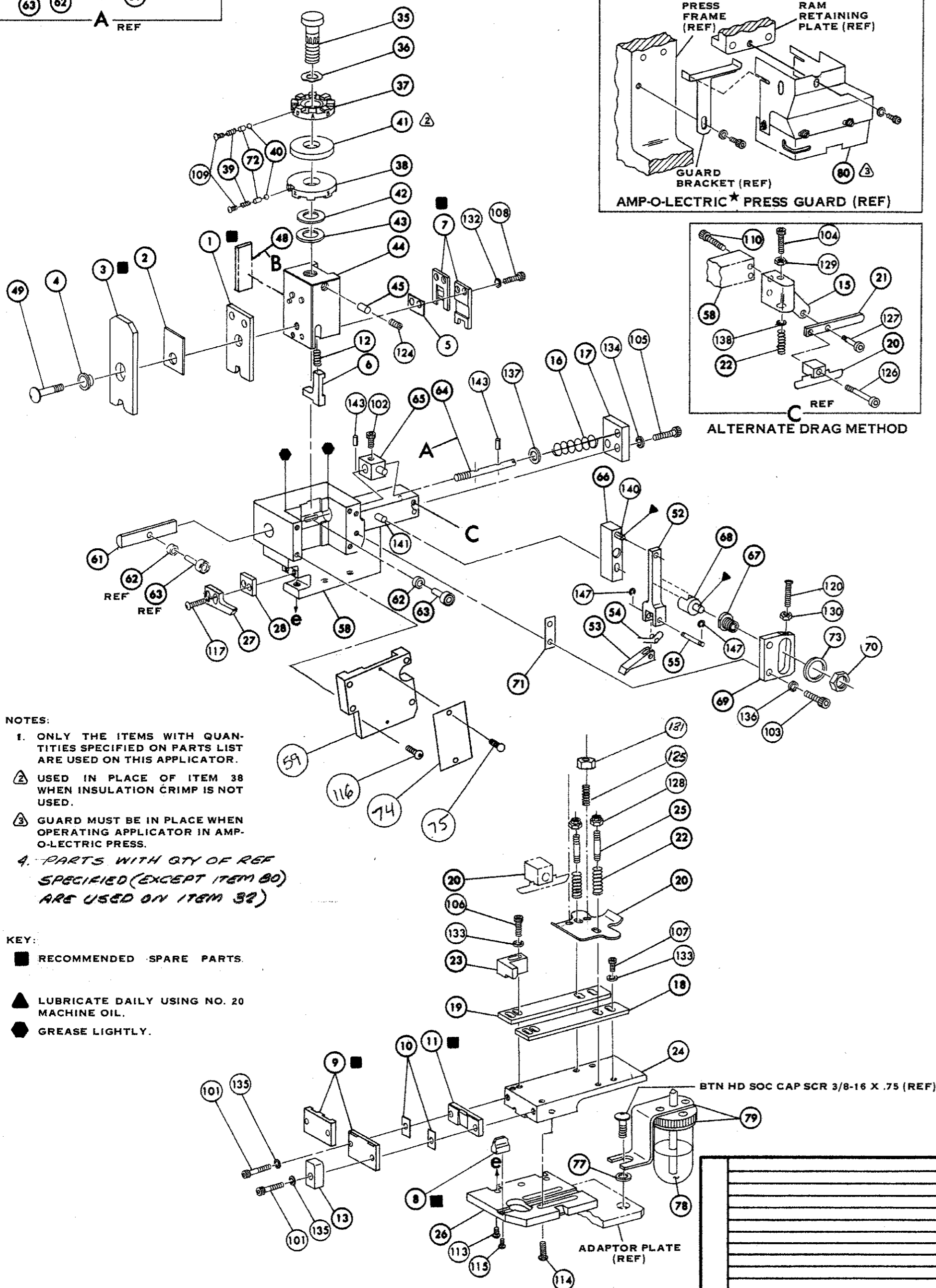
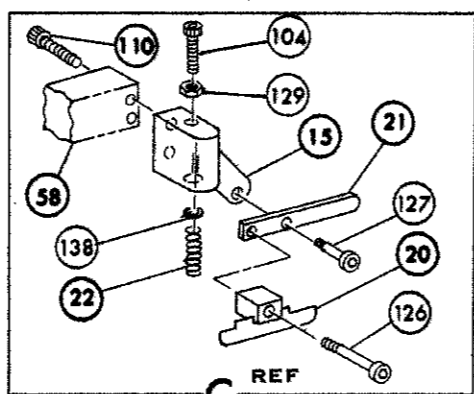
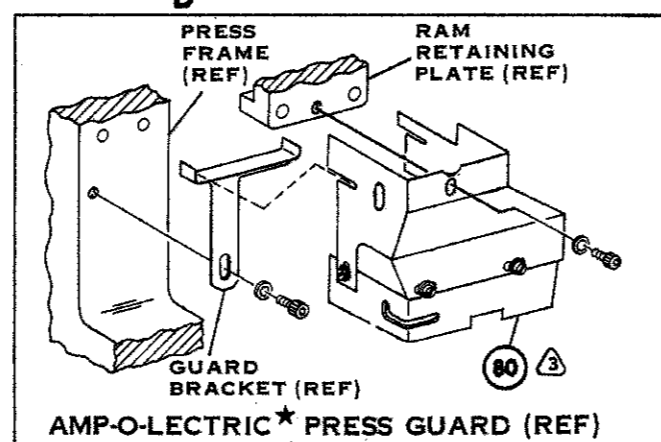
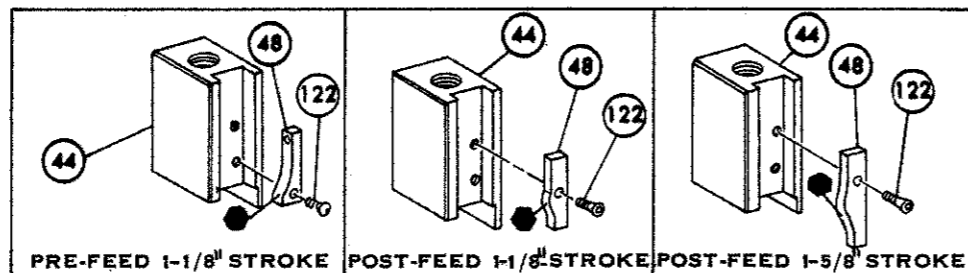
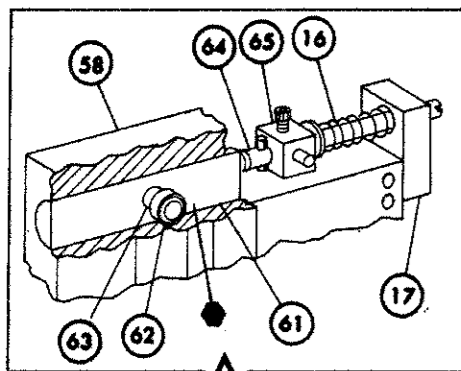

- NOTES:
- ONLY THE ITEMS WITH QUANTITIES SPECIFIED ON PARTS LIST ARE USED ON THIS APPLICATOR.
  - USED IN PLACE OF ITEM 38 WHEN INSULATION CRIMP IS NOT USED.
  - GUARD MUST BE IN PLACE WHEN OPERATING APPLICATOR IN AMP-O-LECTRIC PRESS.
  - PARTS WITH QTY OF REF SPECIFIED (EXCEPT ITEM 80) ARE USED ON ITEM 32.

- KEY:
- RECOMMENDED SPARE PARTS
  - LUBRICATE DAILY USING NO. 20 MACHINE OIL.
  - GREASE LIGHTLY.

REQ.	PART NO.	DESCRIPTION	NO.	REQ.	PART NO.	DESCRIPTION	NO.
			162	REF	690517-1	SPACER	71
			161		22594-8	HEX NUT	70
			160		240628-1	PLATE, ADJ	69
			159		240626-1	SHAFT, PIVOT	68
			158		240633-1	BUSHING	67
			157		455680-1	LEVER, INTERMEDIATE	66
			156		240629-1	BLOCK, PIVOT	65
			155		240632-2	SCREW, ADJ	64
			154		240659-3	PIN, CAM ROLLER	63
			153		240658-1	CAM, ROLLER	62
			152	REF	454398-1	ROD, FEED	61
			151				60
			150	REF	454220-1	CAP, RAM	59
			149	REF	453736-1	HOUSING	58
			148				57
REF	21045-3	RING, RETAINING 'C' (.187 DIA) FEED PIN	147				56
			146	REF	240624-1	PIN, FEED FINGER	55
			145	REF	691499-1	SPRING, FEED FINGER	54
			144	REF	240635-1	FINGER, FEED	53
REF	5- 21028-1	PIN, SLOT SPG (.12 DIA x .50) FEED ADJ ROD	143	REF	240634-1	LEVER, TERMINAL	52
			142				51
REF	1- 21030-7	PIN, DOWEL (.187 DIA x 1.50) HOUSING	141				50
REF	1- 21030-1	PIN, DOWEL (.187 DIA x .50) LEVER	140	1	7-21002-9	BOLT, CRIMPER	49
			139	1	690501-3	CAM, POST FEED 1- 1/8 STROKE	48
			138				47
			137				46
REF	21899-4	WASH, FLAT (NO. 6) DRAG SPRING	136	1	690191-1	PLUG, NYLON	45
REF	21024-5	WASH, LOCK (NO. 10) FEED ADJ PLATE	135	1	455674-1	RAM	44
2	21024-5	WASH, LOCK (NO. 10) SHEAR PLATES	134	1	690125-1	WASHER, LAMINATED	43
REF	21024-5	WASH, LOCK (NO. 10) FEED ROD GUIDE	133	1	690124-1	WASHER, RAM	42
4	21024-4	WASH, LOCK (NO. 8) STRIP GUIDE	132	1	690223-1	SPACER, DISC	41
2	21024-4	WASH, LOCK (NO. 8) SHEAR BLADE	131	1	23241-6	BALL, STEEL	40
REF	21018-4	NUT, HEX MACH (4-40) DRAG	130	1	690170-1	SPRING, COMPRESSION	39
REF	21068-5	NUT, HEX MACH (6-32) FEED ADJ PLATE	129	1		DISC, INSULATION	38
			128	1	4-690692-9	DISC, WIRE	37
2	21022-2	NUT, HEX SELF-LKG (8-32) DRAG STUDS	127	1	22480-5	WASHER, SPRING	36
			126	1	690212-1	POST, RAM	35
2	21004-5	SCR, SKT HD SHLD (.250 DIA x 1.00) DRAG	125				34
2	4-21018-B	SCR, SOC. SET OVAL PT (4-40 x .75) DRAG	124				33
1	21009-2	SCR, SKT SET (1/4-20 x .25) NYLOK RAM	123	1	458980-1	APPLICATOR, BASIC (SUB ASSY)	32
			122				31
1	J- 21002-7	SCR, BUT HD SOC CAP (6-32 x .38) CAM	121				30
REF	3- 21064-2	SCR, RDH HD MACH (6-32 x 1.50) FEED ADJ	120				29
			119				28
			118	1	690419-1	STRIPPER	27
2	2-21002-2	SCR, BTN HD SKT CAP (8-32 x .50) STRIPPER	117	REF	455676-1	PLATE, BASE	26
REF	2- 21002-9	SCR, BTN HD SKT CAP (10-32 x .75) HSG CAP	116	2	22359-8	DRAG, STUD	25
1	22733-8	SCR, BTN HD SKT CAP (8-32 x .38) NYLOK ANVIL	115	1	455678-6	PLATE, STRIP GUIDE	24
4	3- 21002-3	SCR, BTN HD SKT CAP (1/4-20 x .50) STR GDE PL	114				23
REF	1-84073-9	SCR, BTN HD SKT CAP (1/4-20 x .75) BASE PLATE	113	2	4-22281-1	SPRING, DRAG	22
			112		240636-1	LEVER, DRAG	21
			111	1	454177-1	DRAG, STOCK	20
			110	1	458080-2	GUIDE, STRIP REAR	19
1	23030-1	SCR, SKT HD CAP (6-32 x .25) NYLOK C. P. DISC	109	1	458031-2	GUIDE, STRIP FRONT	18
2	2-21000-6	SCR, SKT HD CAP (8-32 x .58) SHEAR BLADE	108	REF	454178-1	GUIDE, FEED ROD	17
3	7-21000-4	SCR, SKT HD CAP (8-32 x .31) STRIP GUIDE	107	REF	4-22284-9	SPRING, FEED RETURN	16
1	7-21000-4	SCR, SKT HD CAP (8-32 x .31) STRIP GUIDE	106		454665-1	ADAPTOR, DRAG	15
REF	3- 21000-7	SCR, SKT HD CAP (10-32 x .75) FD ROD GUIDE	105				14
			104				13
REF	3- 21000-9	SCR, SKT HD CAP (10-32 x 1.00) DRAG SPRING	103				12
REF	3- 21000-6	SCR, SKT HD CAP (10-32 x .62) FD ADJ PLATE	102	1	691901-2	PLATE, REAR SHEAR	11
REF	3- 21000-4	SCR, SKT HD CAP (10-32 x .38) PIVOT BLK	101	2	1200645-6	SPACER, SHEAR PLATE	10
2	3- 21000-8	SCR, SKT HD CAP (10-32 x .88) SHEAR PLATES	80	1	240698-3	PLATE, FRONT SHEAR	9
REF	455745-1	GUARD	79	1	1240684-9	ANVIL	8
			78	1	691157-3	BLADE, SLUG	7
			77				6
			76				5
2	21017-2	SCR, DRIVE (#2 x .19) ID PLATE	75				4
1	461264-1	PLATE, ID	74				3
REF	458109-1	WASHER, FLAT (SPECIAL)	73				2
1	690603-1	SPRING, ASSIST	72	1	456409-5	CRIMPER, WIRE	1

TERM APPL SPEC 114-2084

CRIMPING DATA				THIS APPLICATOR WILL APPLY
PAD LETTER	CRIMP HEIGHT	WIRE SIZE	WIRE STRIP LENGTH	40951
A	.077	#14		41806
B	.068	#16		61192
C	.063	#18		61774
D	NOT USED			
CRIMP	SIZE	TYPE	FEED	PRESS REF.
WIRE	.120	F		
INSULATION			.490	565435-5
INSULATION RANGE		WIRE RANGE	APPLICATOR INSTRUCTION	8039
		18-19		
REMARKS				
AMP-O-LECTRIC POST FEED				
I.D. PLATE (REF): 461264-1				
SET UP PAGE	LAYOUT NO.	AMP HARRISBURG, PENNA.		
458638-1	210			
DATE	APPROVED			
10/4/73	[Signature]			
CHECKED	REL.			
10/6/73	[Signature]			
SCALE	NAME			
NONE				
MINIATURE QUICK CHANGE APPLICATOR				
END-FEED (RING)				

THIS DRAWING IS UNPUBLISHED BY AMP INCORPORATED. ALL RIGHTS RESERVED.

THIS DRAWING IS UNPUBLISHED BY AMP INCORPORATED. ALL RIGHTS RESERVED.

PRINTED IN U.S.A.

LTR	REVISION RECORD	ECN	DATE	LTR	REVISION RECORD	ECN	DATE

DATE	BY	DESCRIPTION
10/12/73	[Signature]	REVISED
10/11/73	[Signature]	REVISED
10/10/73	[Signature]	REVISED
10/9/73	[Signature]	REVISED
10/8/73	[Signature]	REVISED
10/7/73	[Signature]	REVISED
10/6/73	[Signature]	REVISED
10/5/73	[Signature]	REVISED
10/4/73	[Signature]	REVISED
10/3/73	[Signature]	REVISED
10/2/73	[Signature]	REVISED
10/1/73	[Signature]	REVISED