

- 1 HOUSING MATERIAL: GLASS-FILLED POLYMER.
- 2 POST MATERIAL: COPPER ALLOY.
- 3 POST FINISH: DIN 41612 CLASS 2 IN CONTACT AREA. TIN PLATE ON POSTS.
- 4 MARKING ON THIS SIDE.
- 5 RECOMMENDED HOLE SIZE FOR MANUAL APPLICATION OF CONNECTOR ONTO PC BOARD.
- 6 PART NUMBER, DATE CODE MARKED THIS APPROXIMATE AREA.

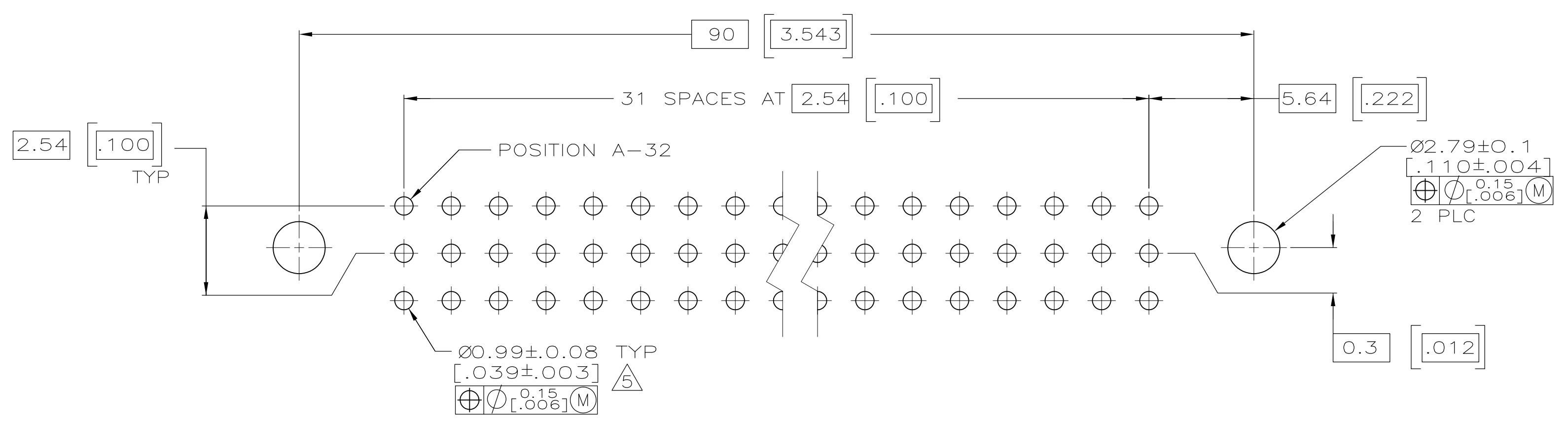
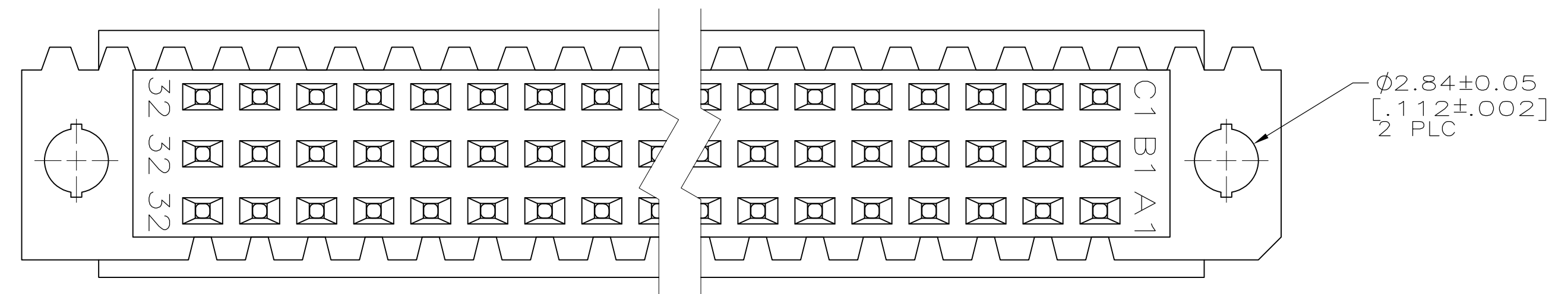
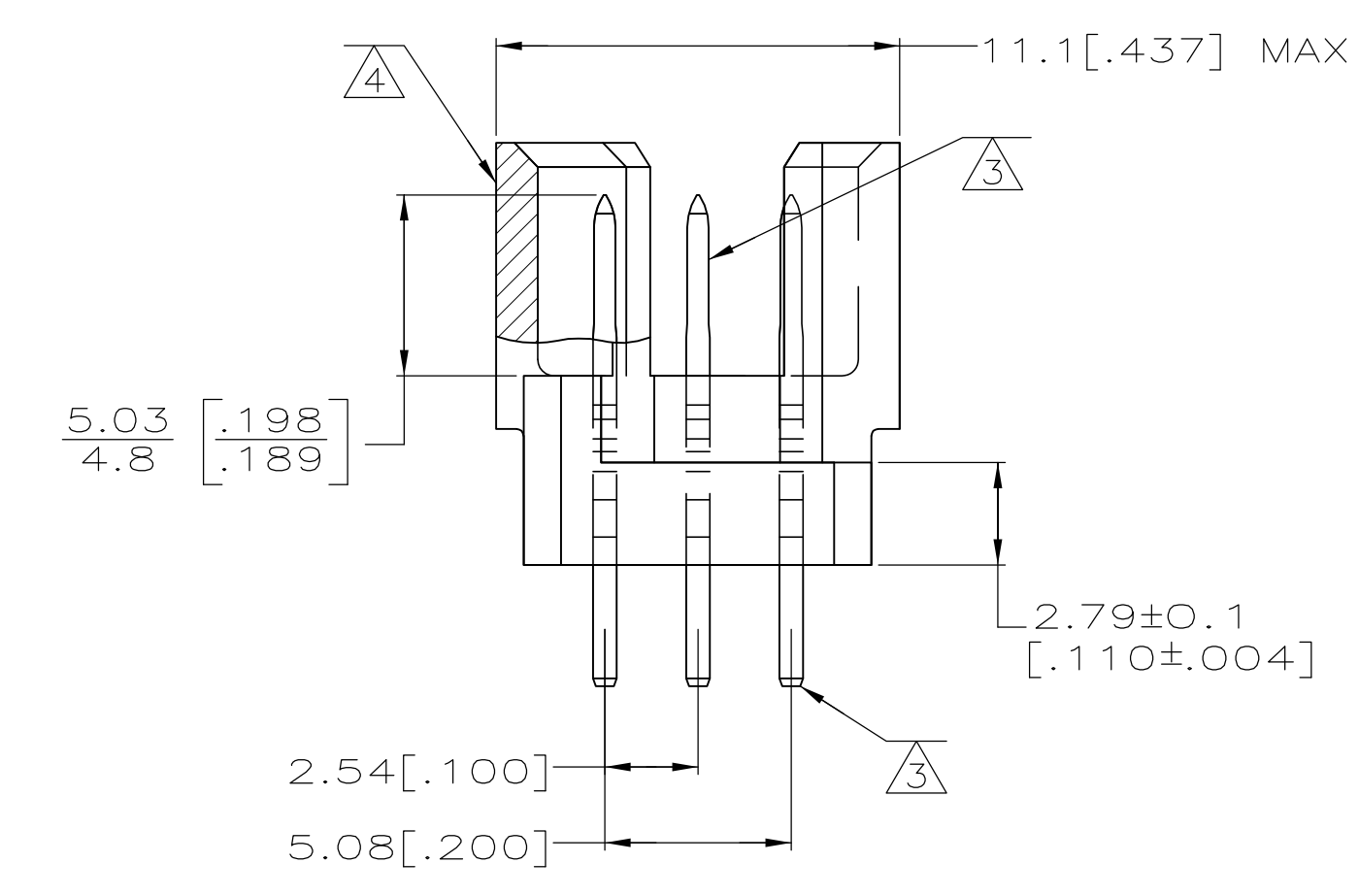
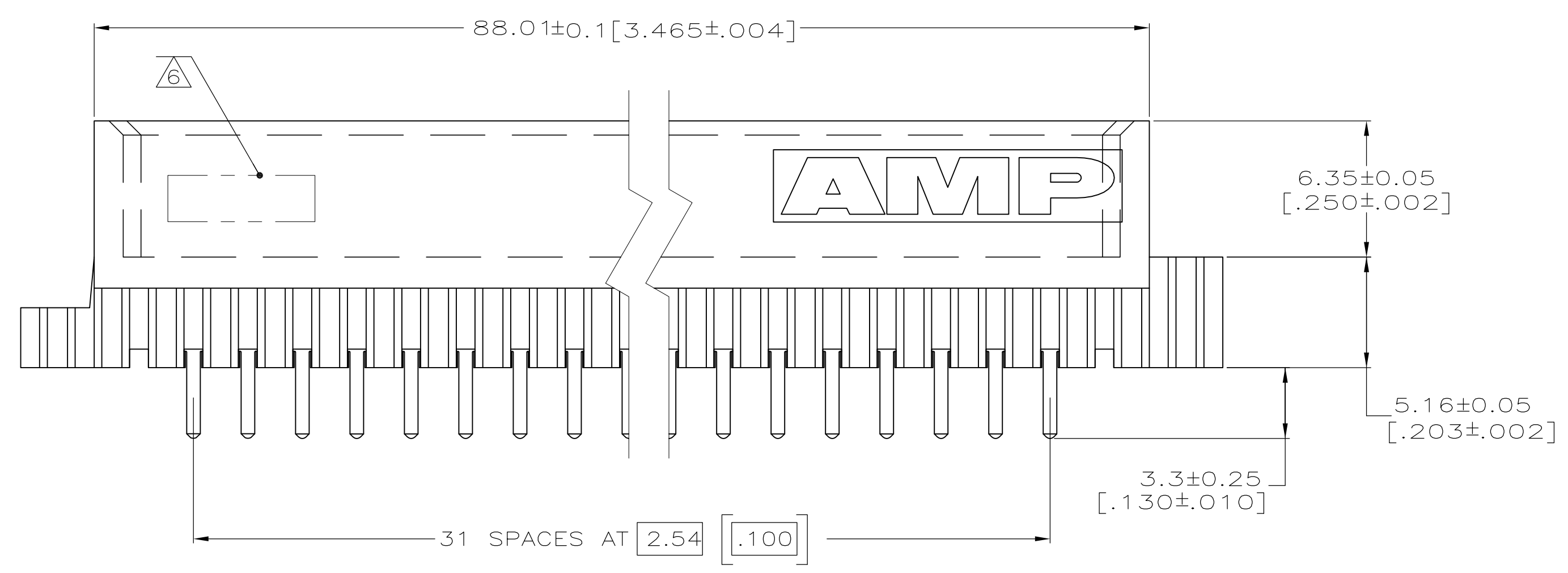
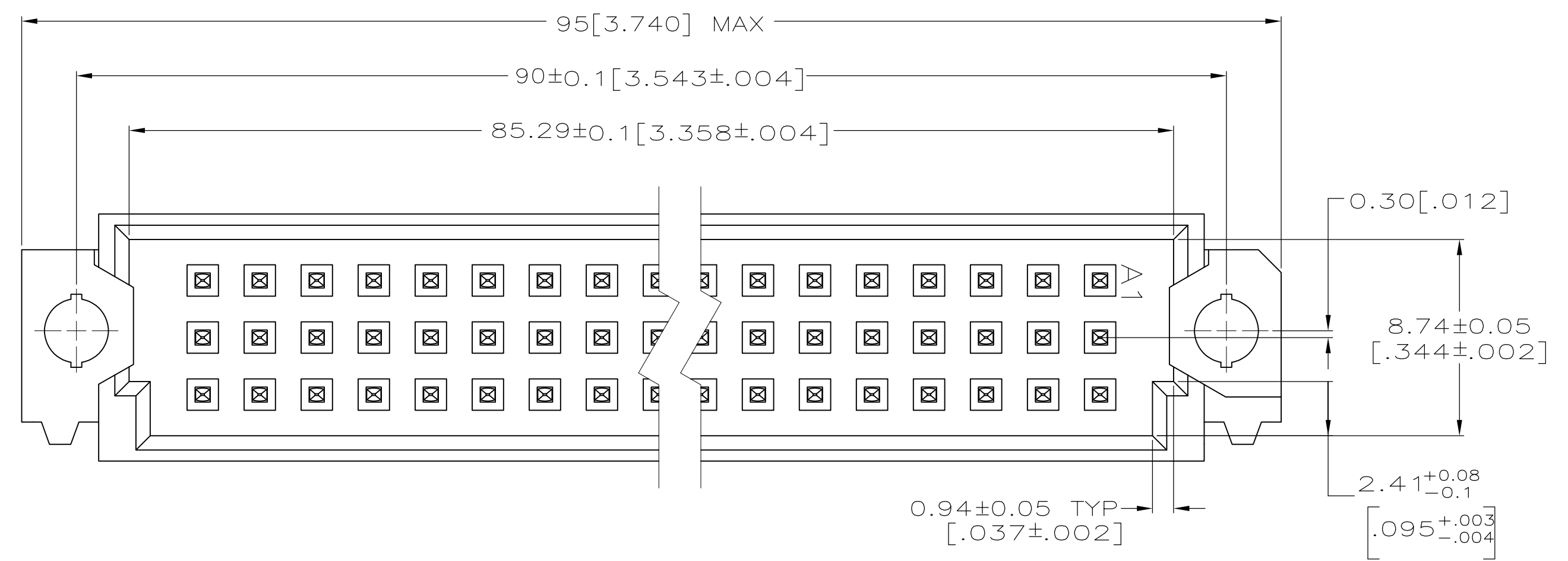

1-32	X	X	X	96	5650908-5
POSITIONS LOADED	C	B	A	NO. OF LOADED POSITION	ASSY PART NUMBER
	ROWS LOADED				

THIS DRAWING IS A CONTROLLED DOCUMENT.		DIN J. POLIGNONE DSMAYOS		TE Connectivity																													
DIMENSIONS: mm [INCHES]		TOLERANCES UNLESS OTHERWISE SPECIFIED:		APVD A. SHARPE DSMAYOS NAME																													
<table border="1"> <tr><td>0 PLC</td><td>± -</td></tr> <tr><td>1 PLC</td><td>± -</td></tr> <tr><td>2 PLC</td><td>± 0.13[.005]</td></tr> <tr><td>3 PLC</td><td>± -</td></tr> <tr><td>4 PLC</td><td>± -</td></tr> <tr><td>ANGLES</td><td>± -</td></tr> </table>		0 PLC	± -	1 PLC	± -	2 PLC	± 0.13[.005]	3 PLC	± -	4 PLC	± -	ANGLES	± -	<table border="1"> <tr><td>APVD</td><td>A. SHARPE DSMAYOS</td></tr> <tr><td>PRODUCT SPEC</td><td></td></tr> <tr><td>APPLICATION SPEC</td><td></td></tr> <tr><td>WEIGHT</td><td></td></tr> </table>		APVD	A. SHARPE DSMAYOS	PRODUCT SPEC		APPLICATION SPEC		WEIGHT		<table border="1"> <tr><td>SIZE</td><td>A1</td></tr> <tr><td>CAGE CODE</td><td></td></tr> <tr><td>DRAWING NO</td><td>5650908</td></tr> <tr><td>RESTRICTED TO</td><td></td></tr> </table>		SIZE	A1	CAGE CODE		DRAWING NO	5650908	RESTRICTED TO	
0 PLC	± -																																
1 PLC	± -																																
2 PLC	± 0.13[.005]																																
3 PLC	± -																																
4 PLC	± -																																
ANGLES	± -																																
APVD	A. SHARPE DSMAYOS																																
PRODUCT SPEC																																	
APPLICATION SPEC																																	
WEIGHT																																	
SIZE	A1																																
CAGE CODE																																	
DRAWING NO	5650908																																
RESTRICTED TO																																	
MATERIAL 1 2		FINISH 3		CUSTOMER DRAWING																													
		SCALE 5:1		SHEET 1 OF 1 REV P																													