

SSA - Smart Current Sensor

Amplified Differential Analog Output and Reinforced Galvanic Isolation



- $\pm 100\text{A}$ to $\pm 1000\text{A}$
- 1500VDC Galvanic Reinforced Isolation
- Amplified Output
- 0.1% Tolerance
- Compared to Hall Effect Technology
 - » Superior Overall Current Measurement Accuracy
 - » Unipolar Power Supply
 - » Lower Temperature Drift
 - » No Periodic Calibration
 - » Higher operating temperature range
- Typical Applications:
 - » Battery Systems
 - » UPS systems
 - » Motor Drives
 - » Frequency Inverters
 - » Fuel Cells



SPECIFICATIONS

Nominal Current (\pm)	100A, 250A, 500A, 1000A - custom values on request	
Maximum Current	2 times nominal	
Power Supply (3.0 to 5.5vdc) high impedance load	3.0V, 20mA typical	→ 5.5V, 40mA typical
Differential Analog Output ± 2.62 volts maximum unclipped	$\pm 100\text{A} = \pm 12.5\text{mV/amp}$ $\pm 250\text{A} = \pm 5\text{mV/amp}$	$\pm 500\text{A} = \pm 2.5\text{mV/amp}$ $\pm 1000\text{A} = \pm 1.25\text{mV/amp}$
Power Dissipation Rated current including primary terminations	100A: 4.5 watts 250A: 14 watts	500A: 27 watts 1000A: 55 watts
DC Offset (maximum @ 25°C)	$\leq \pm 0.4\text{mV}$ (10Hz LP filter)	
Initial Accuracy	$\pm 0.1\%$ (Offset is zeroed prior to calibrating using DC current)	
Linearity over Current Range	$\pm 0.1\%$ of range	
Bandwidth (electronics)	300kHz	
Reaction Time (typical)	1.6 μS (input step function, 50% rise on input to 50% rise on output)	
Common Mode Rejection Ratio	CMRR: -100dB @ DC, -98dB @ 10kHz	
Common Mode Transient Immunity	CMTI: 80kV/ μS typical, 55kV/ μS minimum	
Signal to Noise Ratio (SNR)	VIN = 100 mVPP, fIN = 1 kHz, BW = 10 kHz 80dB min 84dB typical VIN = 100 mVPP, fIN = 10 kHz, BW = 100 kHz 70dB typical	
Long term stability	$< \pm 0.2\%$ 1000 hours 45°C terminal temperature $< \pm 0.5\%$ 1000 hours 100°C terminal temperature	
Reinforced Isolation	1500V _{DC} 1000V _{AC} RMS (maximum continuous working voltage)	
Operating Temperature	- 40°C to +85°C ambient - 40°C to +125°C primary conductor (see derating curve on page 4)	
Storage Temperature	- 55°C to +125°C	
Materials (RoHS Compliant)	Resistance Element: Manganin Terminal Block: Nickel Plated Copper Suitable for Copper, Copper-Clad Aluminum or Aluminum conductors Electronics Housing: 94-V0 rated Potting Material: 94-V0 rated	
Secondary Mating Connector	JST type 04R-JWPF-VSLE-S (housing), SWPR-001T-P025 (contact)	
Optional Accessories	SSA-CABLE-length (pre-terminated mating cable, 1 meter standard) SSA-BASE (Insulated panel mounting fixture (94-V0))	

SSA - Smart Current Sensor

Amplified Differential Analog Output and Reinforced Galvanic Isolation



Standard Configuration

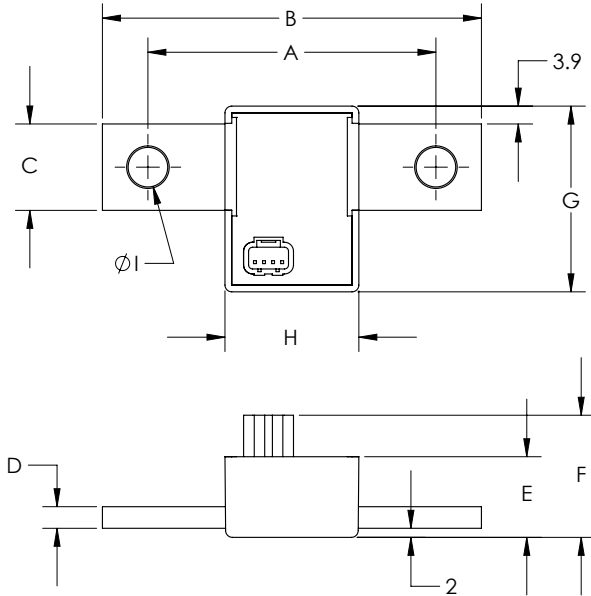

		Dimensions (mm)			
		SSA-100	SSA-250	SSA-500	SSA-1000
A	(±0.5)	63.5	63.5	63.5	63.5
B	(±0.5)	83.8	83.8	83.8	83.8
C	(±0.3)	19.1	19.1	19.1	38.1
D	(±0.3)	4.9	4.9	8	8
E	(±0.3)	17.8	17.8	21.3	21.3
F	(MAX)	29	29	33	33
G	(±0.5)	41	41	41	50
H	(±0.5)	29.8	29.8	29.8	29.8
I	(±0.2)	8.7	8.7	8.7	8.7
J	(±0.3)	-	-	-	19.05
K	(±0.3)	-	-	-	9.5
Mass		80g	90g	121g	215g

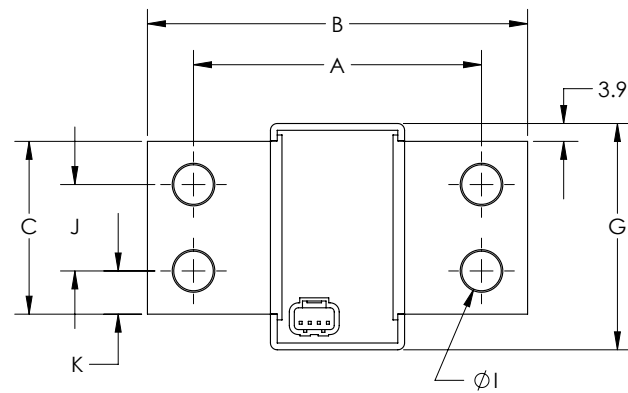

← Current Direction for Positive Output

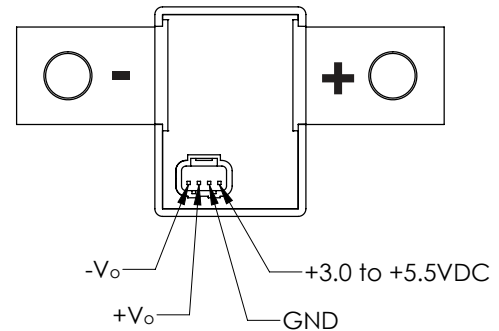

UL file E514971 -

UL 61010-1, 3rd Edition, May 11, 2012, Revised July 19, 2019, CAN/CSA, C22.2 No. 61010-1-2 3rd Edition, Revisions dated July 19, 2019. 600v CAT II, 300v CAT III, Pollution Degree II.

CAT III -

CAT III refers to equipment intended to form part of a building installation.

CAT II -

CAT II refers to equipment intended to be supplied by building wiring.

Product Safety notice -

The SSA current sensor must be used in a manner specified by this datasheet, otherwise the protection provided by the equipment may be impaired. The SSA series should not be treated as a structural part of the installation and must be properly supported on both ends.

Ordering Information

Example: **SSA-250**

100
250
500
1000

Size

SSA - Smart Current Sensor

Amplified Differential Analog Output and Reinforced Galvanic Isolation



SSA-BASE Mounting Fixture (Optional)

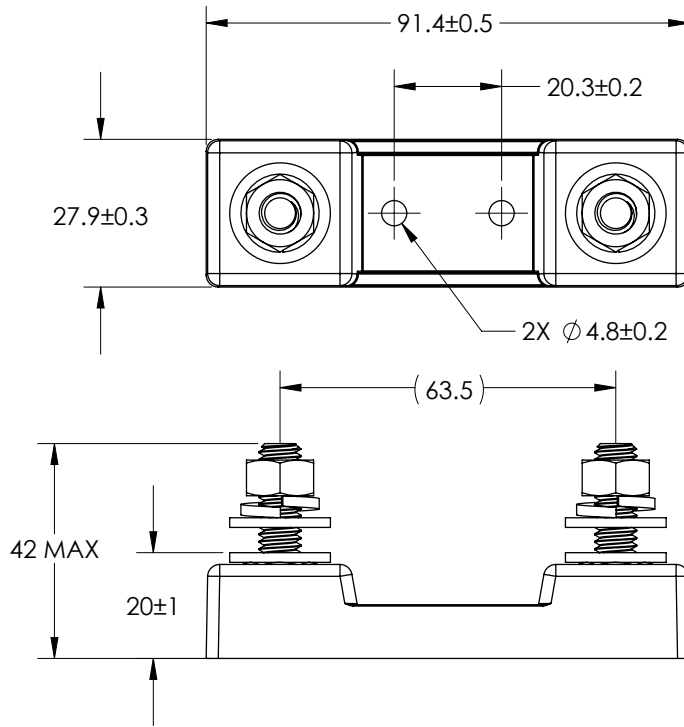

- For SSA-100 thru SSA-500
- Robust design
- 5/16-18 Stainless Steel Hardware
- Torque Nuts:
11-13 ft-lb (15-17.6 N-m)
- UL 94-V0 rated materials



Ordering Info: SSA-BASE

SSA-CABLE Power/Output Connection (Optional)



Differential Output	
White	Analog (-)
Yellow	Analog (+)
Black	Ground
Red	+3.0v to 5.5v

- For all SSA models
- Color coded 22ga wire
- Two twisted pairs
- 1 meter standard length

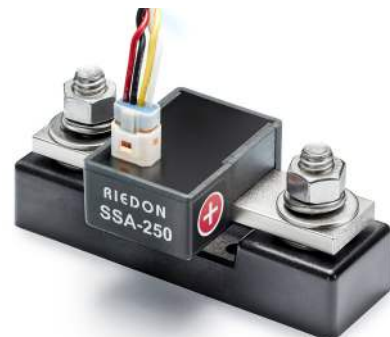

Ordering Info: SSA-CABLE-length

Example: SSA-CABLE-1M

SSA shown with optional accessories

SSA - Smart Current Sensor

Amplified Differential Analog Output and Reinforced Galvanic Isolation



Frequently Asked Questions

Q: How does the Riedon SSA compare with hall effect technology?

A: When compared to hall effect technology, the SSA smart current sensor will offer:

- Immunity to stray magnetic fields
- Unlike closed loop hall sensors, the SSA has a unipolar power supply requirement
- No hysteresis
- Low-noise resolution and offset performance allows accurate low-current measurements
- Superior offset, gain and linearity performance over entire temperature range
- Low noise
- Higher bandwidth (300KHz vs 50KHz)
- Lighter weight
- Superior stability
- No sensitivity to conductor positioning
- No periodic calibration

Here is a document published by Texas Instruments that discusses some of the technical aspects:
<http://www.ti.com/lit/sbaa293>

Q: Is the SSA suitable for AC measurements?

A: The wide bandwidth of the SSA makes it appropriate for measuring AC currents as well as DC

Q: Is there a derating for temperature?

A:

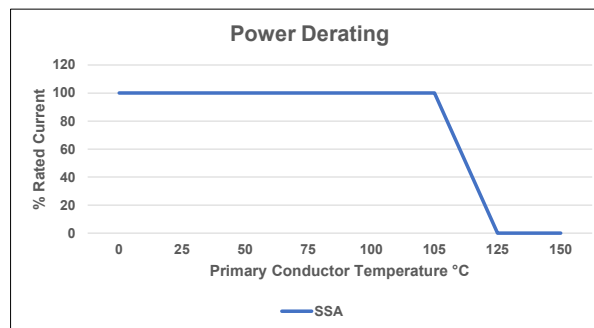

Q: How does the output vary with temperature?

A:

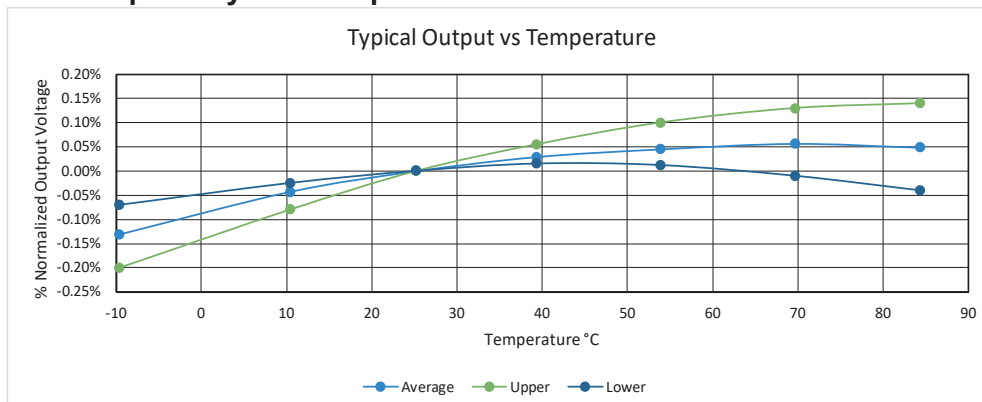

SSA - Smart Current Sensor

Amplified Differential Analog Output and Reinforced Galvanic Isolation



Frequently Asked Questions

Q: What are the overload capabilities of the SSA?

A: The output reading will saturate with an input current that exceeds the corresponding maximum unclipped voltage output of 2.62volts. Ultimately, the overload capabilities are thermally limited per the derating curve.

Q: What is the best way to connect to the SSA's terminals?

A: Make sure connections are clean and well prepared. Bolts to be torqued to the hardware manufacturer's recommendations. There should be sufficient clamping force to ensure proper connection. Overlap shown below should be taken as a minimum. Suitable for Copper, Copper-Clad Aluminum or Aluminum conductors.

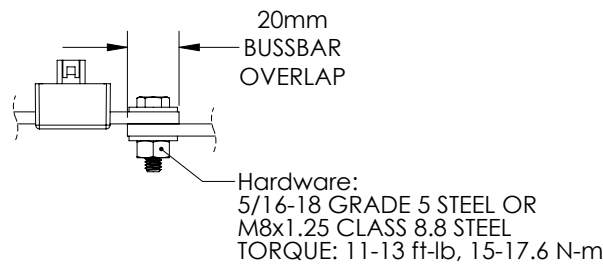

Q: How much heat does the SSA smart current sensor create?

A: A majority of the heat generated by the SSA is dissipated through the primary conductors. Care should be taken to ensure that the primary conductors are sized appropriately given expected amperage and conductor length. We recommend a 70°C maximum conductor temperature. If there are thermal concerns, oversizing the conductors will help minimize the operating temperature of the smart current sensor.

Q: What size wire is suitable for the SSA?

A:

Copper Conductor Ampacity Ratings (continuous)						
mm2	AWG	AMPS (75°C)		mm2	AWG	AMPS (75°C)
13.3	6	65		107	0000 (4/0)	230
21.2	4	85		127	250 MCM	255
33.6	2	115		152	300 MCM	285
42.4	1	130		203	400 MCM	335
54	0 (1/0)	150		253	500 MCM	380
67	00 (2/0)	175		380	750 MCM	475
85	000 (3/0)	200		887	1500 MCM	625

Q: Is it necessary to install the SSA on the low side of the circuit?

A: The SSA series of smart current sensors is completely isolated, so it may be installed in either the low or high side of the circuit.

SSA - Smart Current Sensor

Amplified Differential Analog Output and Reinforced Galvanic Isolation



Frequently Asked Questions

Q: Thermal EMF?

A: Thermal EMF happens when the two sensing terminals of the current sensor experience different temperatures. This phenomenon is essentially eliminated with the differential output of the SSA. It is still possible that the two current carrying terminals could experience a temperature differential, however. This offset would be $0.5\text{mV}/^\circ\text{C}$.

Q: Is there a version with digital outputs?

A: Riedon plans to develop digital output versions in the very near future.

Q: Is there a functional diagram of the general layout?

A:

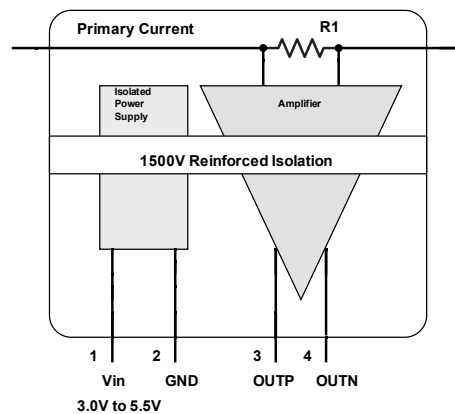

Q: How do I improve the signal to noise ratio (SNR) of the smart current sensor?

A: Oversampling and averaging are two ways to increase SNR and resolution. See the following link for a full explanation: <https://www.cypress.com/file/236481/download>

Q: Is there a way to convert the differential output to a single-ended output?

A:

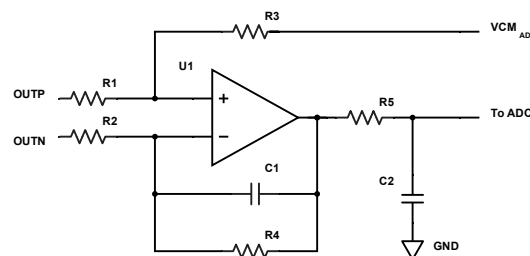

SSA - Smart Current Sensor

Amplified Differential Analog Output and Reinforced Galvanic Isolation



Frequently Asked Questions

Q: Is there another way to read the differential output with single-ended ADCs?

A: The Riedon SSA outputs have a common mode voltage of about +1.44VDC referenced to ground. The difference between OUP+ and OUP- is the differential voltage. You can use two single-ended ADC channels to measure the OUP+ and OUP- voltages referenced to ground and then just subtract the two in software to find the differential voltage. Ideally you would do a simultaneous measurement if possible.

For example: If OUP+ measures 1.85V and OUP- measures 1.03V the differential voltage is 1.85-1.03=0.82V

Q: I notice a high frequency noise on the output signal, why is this?

A: The Riedon SSA smart current sensor has an output chopper circuit at 625KHz. This is how we achieve the good DC-accuracy and low temperature drift of offset and gain. Chopping noise is the differential errors (mismatch, etc) that have been modulated to high frequency to remove them from the baseband. The chopping noise is far above the SSA bandwidth of 300KHz. Use an analog filter to attenuate if necessary, see below.

Q: How do I improve the stability of precision DC current readings?

A: **Analog Filtering:** The Riedon SSA smart current sensor has no internal filtering to maximize its 300KHz bandwidth for high speed AC measurements. Most applications will operate at much lower frequencies and would benefit greatly from analog filtering, especially for DC signals. A low pass RC filter before the A/D converter will improve the signal. Pick the lowest practical filter frequency. Typically one would prioritize lower resistance values and higher capacitances to reduce Johnson noise and output impedance.

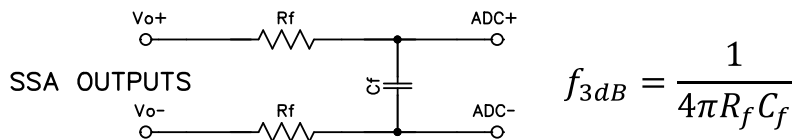

A: **Digital Filtering:** The filtering can be done digitally by the CPU. Averaging multiple readings will stabilize the readings at the cost of CPU cycles.

SSA - Smart Current Sensor

Amplified Differential Analog Output and Reinforced Galvanic Isolation



Frequently Asked Questions

Q: I'm getting overshoot on fast rising currents, why?

A: When using the SSA series in square wave or pulse applications without filtering, the output will have an excessive amplitude due to the skin effect of the shunt. This will be true with microsecond rise-time currents.

The output of the shunt is inversely proportional to its effective cross sectional area. For the first couple of microseconds the current is flowing on the surface of the resistance material and not evenly across the whole cross sectional area like with lower frequency currents. The higher the $\Delta I/\Delta t$, the lower the effective cross section which results in a higher resistance and a higher output voltage. In under 10 micro-seconds the current is flowing through the whole cross section and the output returns to normal.

The amplitude of the pulse is hard to quantify as it is highly dependent on the rest of the circuit's reactance. Filtering is the usual answer. This can either be placed on the output of the SSA shunt before the ADC or Riedon can add a filter internally on the sensing side of the electronics. Contact us if this is required.

SHUNT CROSS SECTION



Current Flowing Through Entire Cross Section



Current Flowing Only On Surface

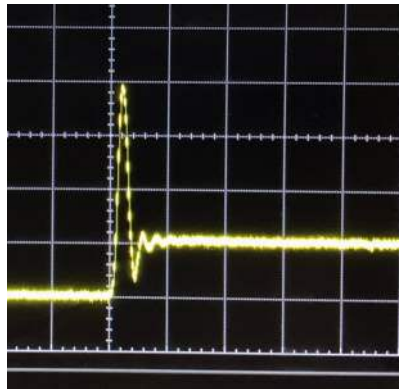

Step response from Fluke 5220A amplifier at 20A square-wave current (no load), 20 μ s/div range