

April 1995

150A, 700V - 1000V Ultrafast Diodes

Features

- Ultrafast with Soft Recovery <125ns
- Operating Temperature +175°C
- Reverse Voltage Up To 1000V
- Avalanche Energy Rated
- Planar Construction

Applications

- Switching Power Supplies
- Power Switching Circuits
- General Purpose

Description

RURU15070, RURU15080 and RURU15090 and RURU150100 are ultrafast diodes with soft recovery characteristics ($t_{RR} < 125ns$). They have low forward voltage drop and are silicon nitride passivated ion-implanted epitaxial planar construction.

These devices are intended for use as freewheeling/clamping diodes and rectifiers in a variety of switching power supplies and other power switching applications. Their low stored charge and ultrafast recovery with soft recovery characteristic minimizes ringing and electrical noise in many power switching circuits reducing power loss in the switching transistors.

PACKAGING AVAILABILITY

PART NUMBER	PACKAGE	BRAND
RURU15070	TO-218	RURU15070
RURU15080	TO-218	RURU15080
RURU15090	TO-218	RURU15090
RURU150100	TO-218	RURU150100

NOTE: When ordering, use the entire part number.

Package

JEDEC STYLE SINGLE LEAD TO-218

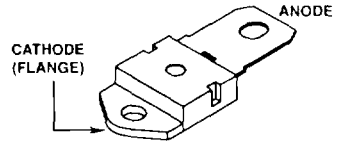

Symbol



Absolute Maximum Ratings $T_C = +25^\circ C$, Unless Otherwise Specified

	RURU15070	RURU15080	RURU15090	RURU150100	UNITS
Peak Repetitive Reverse Voltage V_{RRM}	700	800	900	1000	V
Working Peak Reverse Voltage V_{RWM}	700	800	900	1000	V
DC Blocking Voltage V_R	700	800	900	1000	V
Average Rectified Forward Current $I_{F(AV)}$ ($T_C = +65^\circ C$)	150	150	150	150	A
Repetitive Peak Surge Current I_{FSM} (Square Wave, 20kHz)	300	300	300	300	A
Nonrepetitive Peak Surge Current I_{FSM} (Halfwave, 1 Phase, 60Hz)	1500	1500	1500	1500	A
Maximum Power Dissipation P_D	375	375	375	375	W
Avalanche Energy (L = 40mH) E_{AVL}	50	50	50	50	mJ
Operating and Storage Temperature T_{STG}, T_J	-65 to +175	-65 to +175	-65 to +175	-65 to +175	°C

Specifications RURU15070, RURU15080, RURU15090, RURU150100

Electrical Specifications $T_C = +25^\circ\text{C}$, Unless Otherwise Specified

SYMBOL	TEST CONDITION	LIMITS												UNITS
		RURU15070			RURU15080			RURU15090			RURU150100			
		MIN	TYP	MAX	MIN	TYP	MAX	MIN	TYP	MAX	MIN	TYP	MAX	
V_F	$I_F = 150\text{A}$, $T_C = +25^\circ\text{C}$	-	-	1.9	-	-	1.9	-	-	1.9	-	-	1.9	V
V_F	$I_F = 150\text{A}$, $T_C = +150^\circ\text{C}$	-	-	1.7	-	-	1.7	-	-	1.7	-	-	1.7	V
I_R	$V_R = 700\text{V}$, $T_C = +25^\circ\text{C}$	-	-	500	-	-	-	-	-	-	-	-	-	μA
	$V_R = 800\text{V}$, $T_C = +25^\circ\text{C}$	-	-	-	-	-	500	-	-	-	-	-	-	μA
	$V_R = 900\text{V}$, $T_C = +25^\circ\text{C}$	-	-	-	-	-	-	-	500	-	-	-	-	μA
	$V_R = 1000\text{V}$, $T_C = +25^\circ\text{C}$	-	-	-	-	-	-	-	-	-	-	500	-	μA
I_R	$V_R = 700\text{V}$, $T_C = +150^\circ\text{C}$	-	-	3.0	-	-	-	-	-	-	-	-	-	mA
	$V_R = 800\text{V}$, $T_C = +150^\circ\text{C}$	-	-	-	-	-	3.0	-	-	-	-	-	-	mA
	$V_R = 900\text{V}$, $T_C = +150^\circ\text{C}$	-	-	-	-	-	-	-	3.0	-	-	-	-	mA
	$V_R = 1000\text{V}$, $T_C = +150^\circ\text{C}$	-	-	-	-	-	-	-	-	-	-	3.0	-	mA
t_{RR}	$I_F = 1\text{A}$, $di_F/dt = 100\text{A}/\mu\text{s}$	-	-	125	-	-	125	-	-	125	-	-	125	ns
	$I_F = 150\text{A}$, $di_F/dt = 100\text{A}/\mu\text{s}$	-	-	200	-	-	200	-	-	200	-	-	200	ns
t_A	$I_F = 150\text{A}$, $di_F/dt = 100\text{A}/\mu\text{s}$	-	100	-	-	100	-	-	100	-	-	100	-	ns
t_B	$I_F = 150\text{A}$, $di_F/dt = 100\text{A}/\mu\text{s}$	-	75	-	-	75	-	-	75	-	-	75	-	ns
$R_{\theta JC}$		-	-	0.4	-	-	0.4	-	-	0.4	-	-	0.4	$^\circ\text{C}/\text{W}$

DEFINITIONS

V_F = Instantaneous forward voltage ($p_w = 300\mu\text{s}$, $D = 2\%$).

I_R = Instantaneous reverse current.

t_{RR} = Reverse recovery time (See Figure 2), summation of $t_A + t_B$.

t_A = Time to reach peak reverse current (See Figure 2).

t_B = Time from peak I_{RM} to projected zero crossing of I_{RM} based on a straight line from peak I_{RM} through 25% of I_{RM} (See Figure 2).

$R_{\theta JC}$ = Thermal resistance junction to case.

E_{AVL} = Controlled avalanche energy (See Figures 7 and 8).

p_w = pulse width.

D = duty cycle.

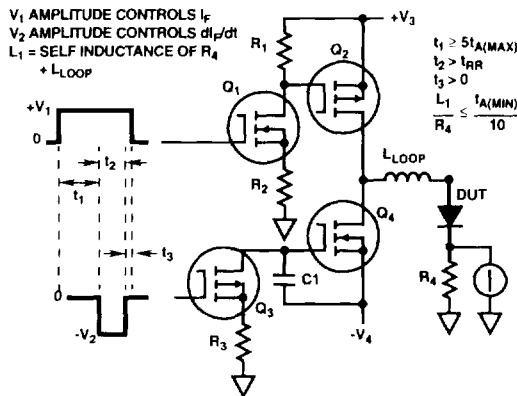

FIGURE 1. t_{RR} TEST CIRCUIT

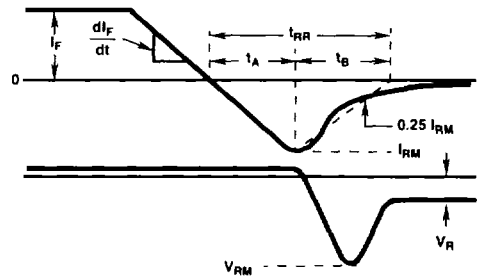

FIGURE 2. t_{RR} WAVEFORMS AND DEFINITIONS

Typical Performance Curves

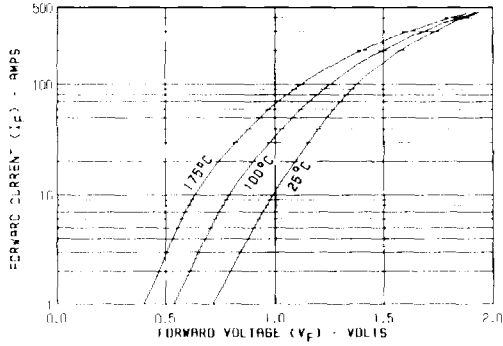

FIGURE 3. TYPICAL FORWARD CURRENT vs FORWARD VOLTAGE DROP

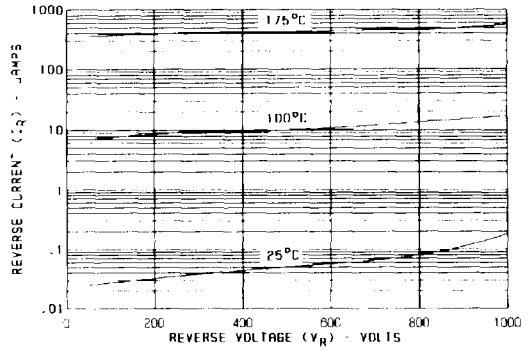

FIGURE 4. TYPICAL REVERSE CURRENT vs VOLTAGE

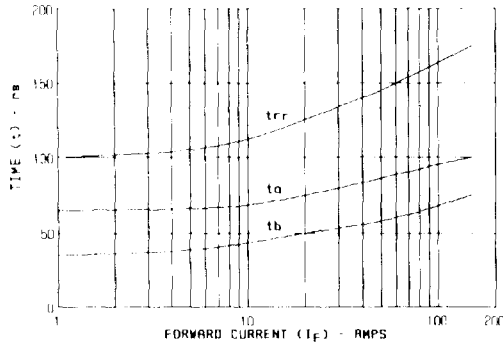

FIGURE 5. TYPICAL t_{RR} , t_A AND t_B CURVES vs FORWARD CURRENT

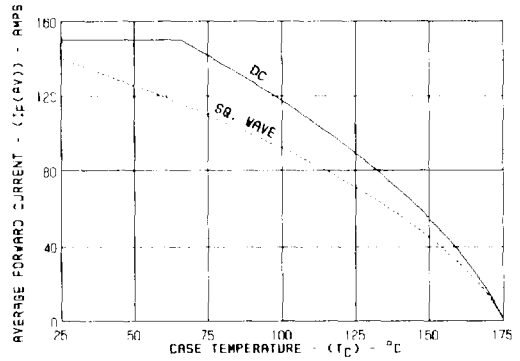

FIGURE 6. CURRENT DERATING CURVE FOR ALL TYPES

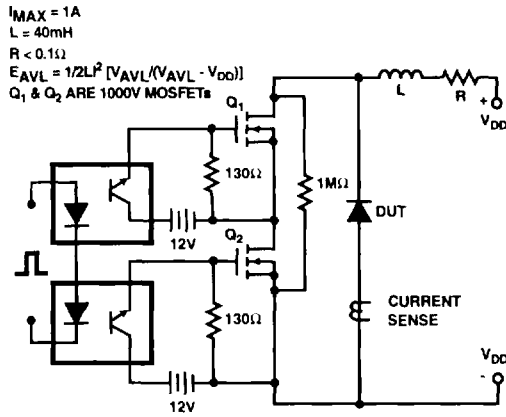

FIGURE 7. AVALANCHE ENERGY TEST CIRCUIT

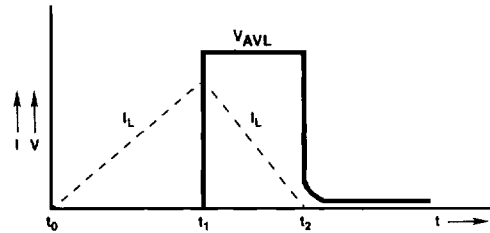

FIGURE 8. AVALANCHE CURRENT AND VOLTAGE WAVEFORMS

5
ULTRAFAST
SINGLE DIODES