

# DIGITAL Potentiometer™

## Manual

*All Mikroelektronika's development systems feature a large number of peripheral modules expanding microcontroller's range of application and making the process of program testing easier. In addition to these modules, it is also possible to use numerous additional modules linked to the development system through the I/O port connectors. Some of these additional modules can operate as stand-alone devices without being connected to the microcontroller.*

# Additional Board

 **MikroElektronika**

SOFTWARE AND HARDWARE SOLUTIONS FOR EMBEDDED WORLD ...making it simple

## DIGITAL Potentiometer Additional Board

The *DIGITAL Potentiometer* additional board is used for digital resistance regulation. Resistance regulation is performed via SPI communication between the additional board and the microcontroller supplied on a development system. The board is connected to a development system via a 2x5 female connector on the additional board and a 2x5 male connector on the development system. Depending on the development system to be connected to the additional board, it is necessary to set the appropriate switches on the DIP switch SW1 to the ON position. Screw terminals CN2 and CN3 are used to connect the potentiometer to a controlled device (for example, audio amplifier's volume regulation). Next to these connectors, there are pins the marks of which have the following meanings:

- PA - potentiometer terminal A connection;
- PW - potentiometer wiper connection; and
- PB - potentiometer terminal B connection.

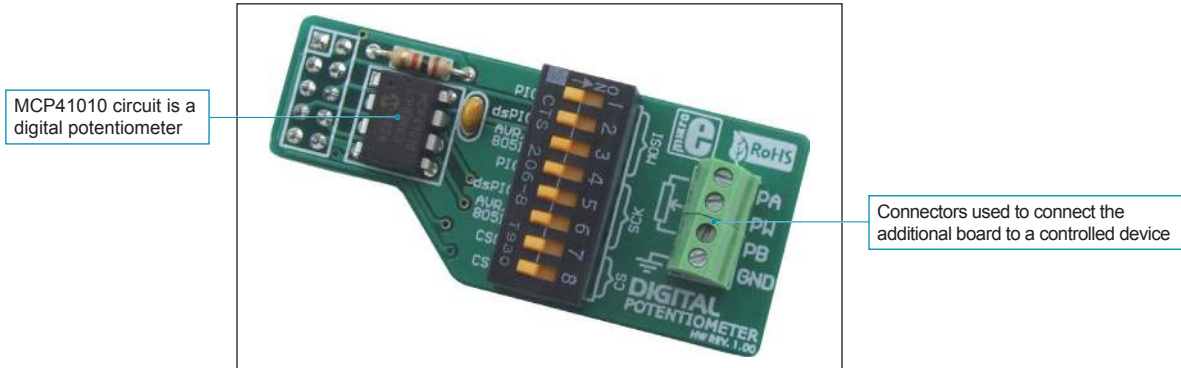

Figure 1: *DIGITAL Potentiometer* additional board

DIP switch SW1 is used to turn on MOSI, SCK and CS lines that connect a microcontroller and the additional board.

When the *DIGITAL Potentiometer* board is connected to EasyPIC, LV18F, EasyLV-18F, Easy24-33 and BigPIC development systems, the following switches on the DIP switch SW1 should be set to the ON position:

- SW1-1 -> MOSI
- SW1-4 -> SCK

For EasyAVR and Easy8051 development systems, the following switches should be set to the ON position:

- SW1-3 -> MOSI
- SW1-6 -> SCK

For the EASYdsPIC development system, the following switches on the DIP switch SW1 should be set to the ON position:

- SW1-2 -> MOSI
- SW1-5 -> SCK

The *DIGITAL Potentiometer* additional board is capable of regulating up to 10k resistance.

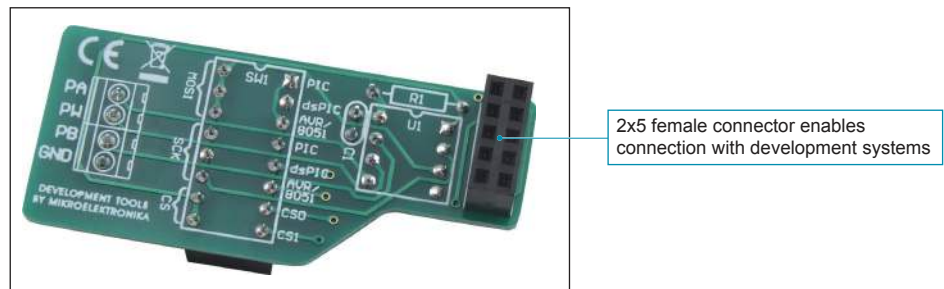

Figure 2: Back of the *DIGITAL Potentiometer* additional board

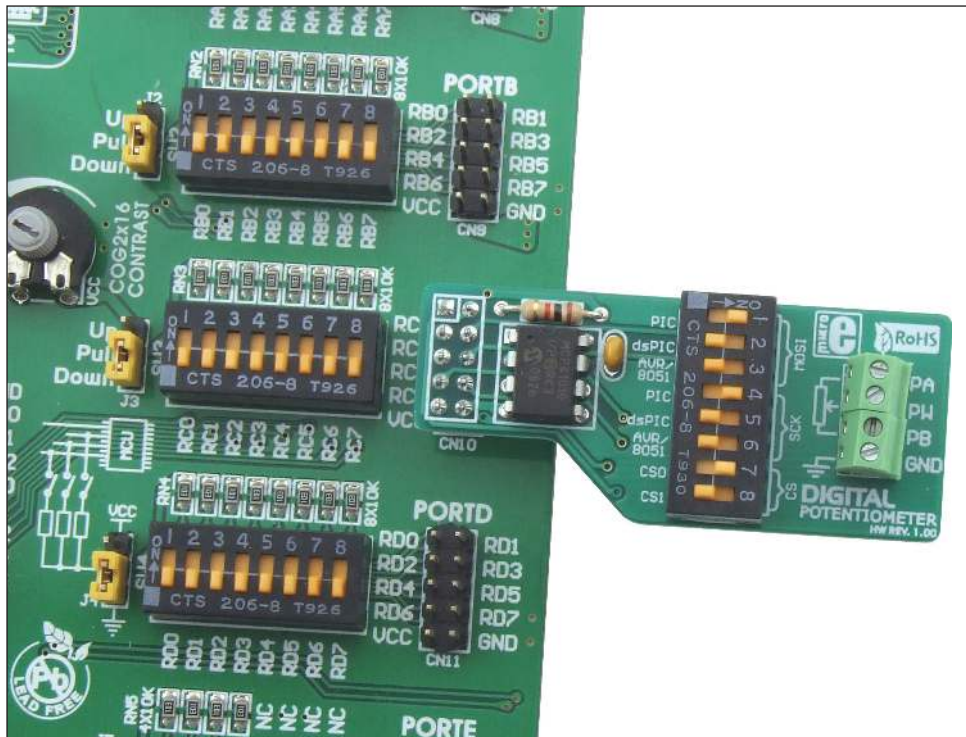

Figure 3: DIGITAL Potentiometer additional board connected to a development systems

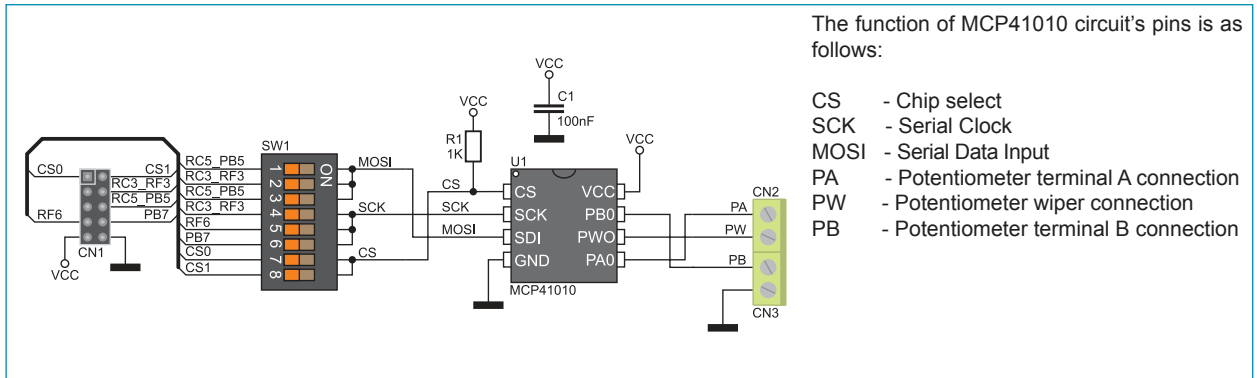

Figure 4: DIGITAL Potentiometer additional board connection schematic



**MikroElektronika**  
SOFTWARE AND HARDWARE SOLUTIONS FOR EMBEDDED WORLD ...making it simple

If you want to learn more about our products, please visit our website at [www.mikroe.com](http://www.mikroe.com)

If you are experiencing some problems with any of our products or just need additional information, please place your ticket at [www.mikroe.com/en/support](http://www.mikroe.com/en/support)

If you have any questions, comments or business proposals, do not hesitate to contact us at [office@mikroe.com](mailto:office@mikroe.com)