

REVISIONS			
REV	DESCRIPTION, ECN, EAR NO.	DATE	APP'D
A	PRODUCT DRAWING (EAR14988)	JAN10/22	K.L.

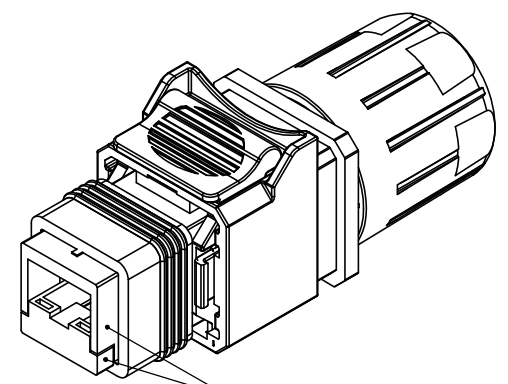

THE TOP & BOTTOM PLUG COVERS HAVE A POKE-YOKE FEATURE. THEY CAN ONLY BE ASSEMBLED ONTO THE PLUG AND INTO THE HOOD BODY IN ONE WAY.

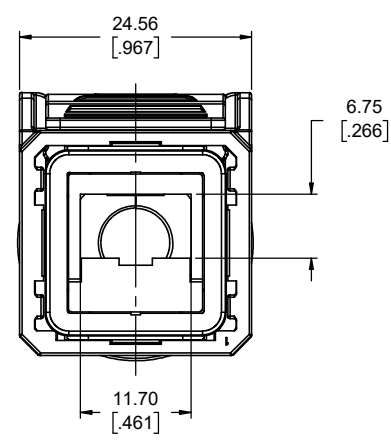
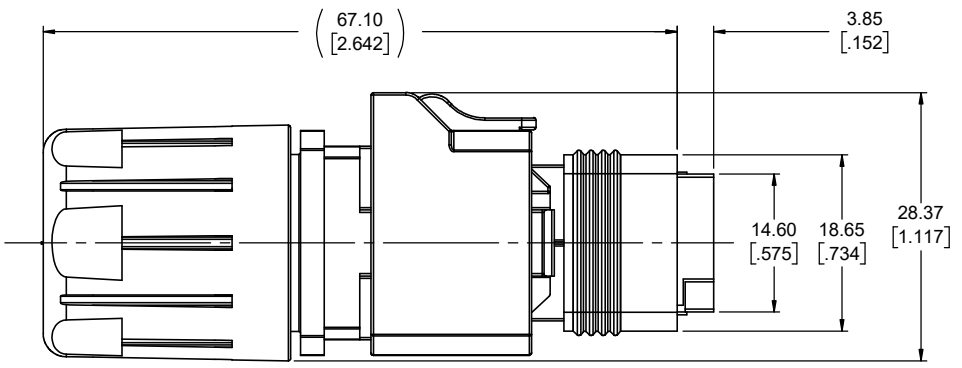
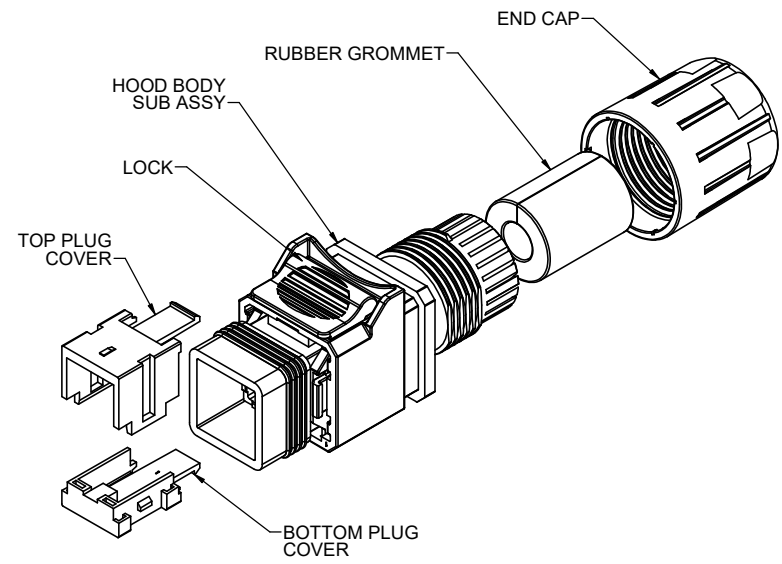
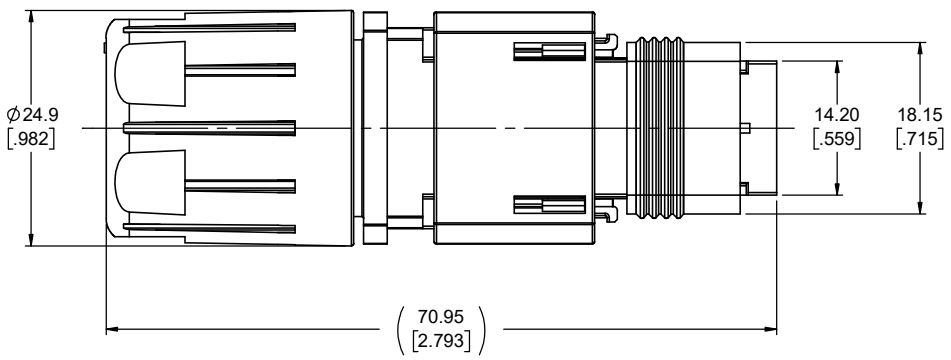

**NOTES:**

- MATERIAL: RoHS COMPLIANT PER EU DIRECTIVE 2011/65/EU AND AMENDMENTS.
  - HOOD COVERS, BODY, SLIDE & END CAP : PBT GLASS REINFORCED, COLOUR: BLACK
  - HOOD LOCK: PBT GLASS REINFORCED, COLOUR: RED
  - GASKETS & GROMMET: SILICONE RUBBER, COLOUR: BLACK
- NDH HOOD FOR RJ45 CONNECTORS IS INTENDED FOR USE WITH MODULAR JACKS THAT HAVE PLUG TAB DOWN ORIENTATION. PLUGS MAY BE SHIELDED OR NON-SHIELDED. NOTE THAT SOME PLUG OVER-MOULDLS OR BOOT DESIGNS MAY NOT BE SUITABLE.
- OPERATING TEMPERATURE -40° TO +80°C.
- NDH-R100 HOODS ARE PART OF AN IP67 SEALED SOLUTION WITH PUSH/PULL MATING FOR RJ45 ETHERNET APPLICATIONS. THE IP67 RATING APPLIES IN THE MATED CONDITION FOR BOTH THE ENCLOSURE AND THE MATING INTERFACE.
- FOR THE PCB MOUNTED MODULAR JACK, SEE AMPHENOL DRAWING P-RJULE-4X183-01. THE JACK IS AN 8 CONTACT, SHIELDED, TAB DOWN, ULTRA LOW PROFILE, RIGHT ANGLE DESIGN CONNECTOR.
- FOR THE BULKHEAD, REFER TO AMPHENOL DRAWING P-NDH-N200.
- FOR PART NUMBERS WITH CABLE ASSEMBLY AND/OR BULKHEAD INCLUDED, REFER TO AMPHENOL DRAWINGS P-NDH-R4AX-AXXA AND P-NDH-R5AX-AXXA.

**AMPHENOL PART NUMBER: NDH-R100**



UNLESS SPECIFIED OTHERWISE	DRAWN	P. GOBUI	JAN07/22
PRIMARY UNITS MILLIMETRES	CHECKED	K. LAMBIE	JAN10/22
SECONDARY UNITS INCHES	M.E. APP'D		
REFERENCE IN PARENTHESES	Q.A. APP'D		
GENERAL TOLERANCES	DWG APPR.		
1 DECIMAL PLACE	ENG. REL. NO.	EAR 14988	
2 DECIMAL PLACES	REF.		
3 DECIMAL PLACES	THIRD ANGLE PROJECTION		
ANGULAR DEGREES	DO NOT SCALE DRAWING		

<b>Amphenol Canada Corp.</b> Commercial Products	
NDH SERIES RJ HOOD KIT, TAB DOWN, IP67 RATING, RoHS COMPLIANT	
DWG. NO.	REV
<b>P-NDH-R100</b>	<b>A</b>
CODE ID NO. 03554	DWG SIZE: X
SCALE: 2:1	SHEET 1 OF 2

REVISIONS			
REV	DESCRIPTION, ECN, EAR NO.	DATE	APP'D
A	PRODUCT DRAWING (EAR14988)	JAN10/22	K.L.

**BULKHEAD PORT SPACING**

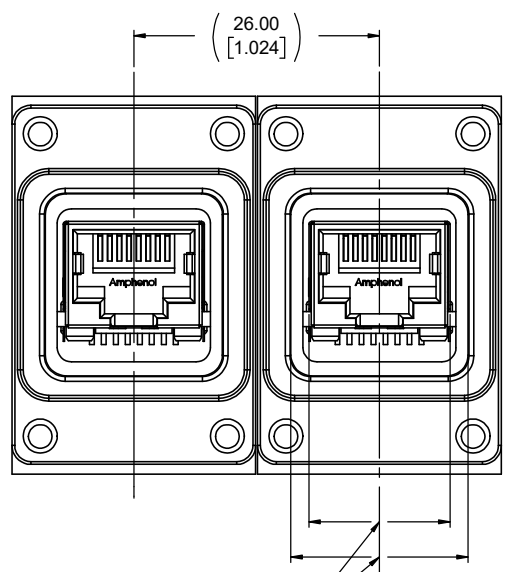

±0.6mm CENTERING OF THE BOARD CONNECTOR WITH BULKHEAD CAVITY

**APPLICATION NOTE:**

IF A CAST OR MOULDED PANEL IS NOT DESIRED TO ACHIEVE A BLIND HOLE SUITABLE FOR THE 6mm THREAD LENGTH, BLIND SEALED PEM NUTS OR MOUNTING SCREWS WITH A BUILT IN O-RING UNDER THE SEALING HEAD CAN ALSO BE USED TO ACHIEVE A PROPER MOUNTING HOLE SEAL.

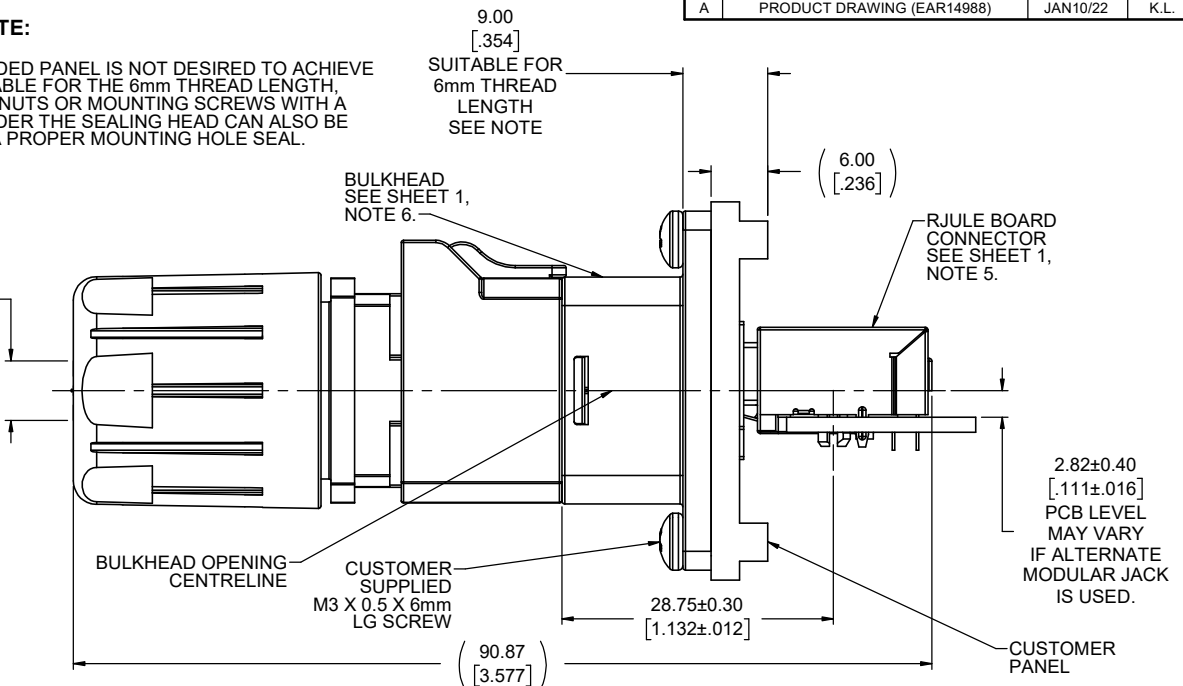

**APPLICATION VIEWS**

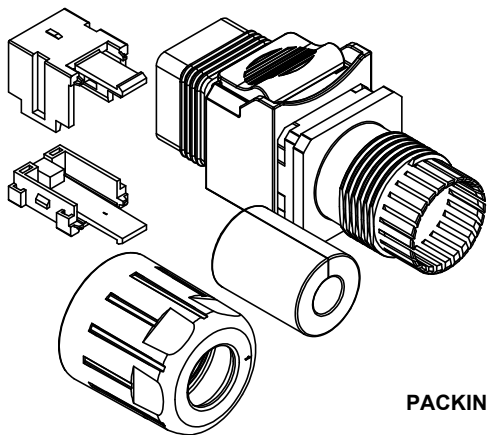

**PACKING CONFIGURATION NDH-R100**

EACH OF THE ITEMS SHOWN ARE SUPPLIED BULK PACKED. EACH CARTON TO PROVIDE AN EQUAL NUMBER OF PARTS.

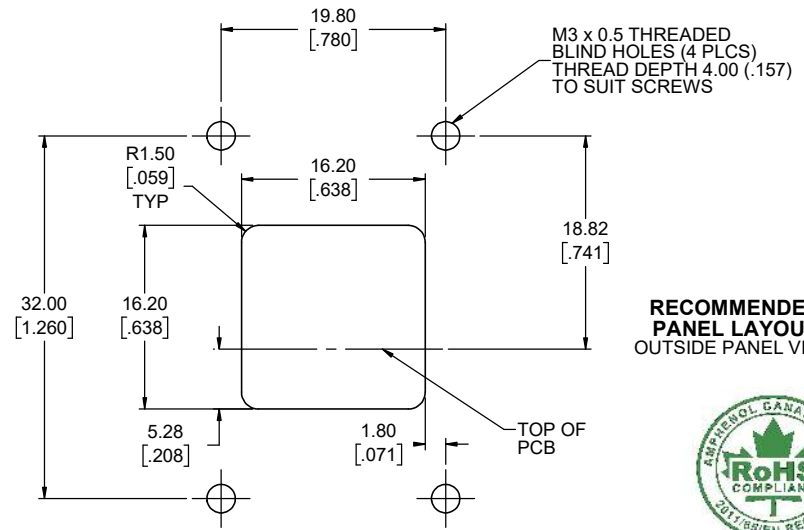

**RECOMMENDED PANEL LAYOUT**  
OUTSIDE PANEL VIEW



THIS DOCUMENT CONTAINS PROPRIETARY INFORMATION AND SUCH INFORMATION MAY NOT BE DISCLOSED TO OTHERS FOR ANY PURPOSE OR USED FOR MANUFACTURING PURPOSES WITHOUT WRITTEN PERMISSION FROM AMPHENOL CANADA CORP.

UNLESS SPECIFIED OTHERWISE	DRAWN	P. GOBUI	JAN07/22
PRIMARY UNITS MILLIMETRES	CHECKED	K. LAMBIE	JAN10/22
SECONDARY UNITS INCHES	M.E. APP'D		
REFERENCE IN PARENTHESES	Q.A. APP'D		
GENERAL TOLERANCES	DWG APPR.		
1 DECIMAL PLACE	ENG. REL. NO.	EAR 14988	
2 DECIMAL PLACES	REF.		
3 DECIMAL PLACES	THIRD ANGLE PROJECTION		
ANGULAR DEGREES	DO NOT SCALE DRAWING		

<b>Amphenol Canada Corp.</b> Commercial Products			
NDH SERIES RJ HOOD KIT, TAB DOWN, IP67 RATING, RoHS COMPLIANT			
DWG. NO.	P-NDH-R100		REV A
CODE ID NO. 03554	DWG SIZE: X	SCALE: X	SHEET 2 OF 2