

NPA 201

Digital Output Absolute Pressure Sensor

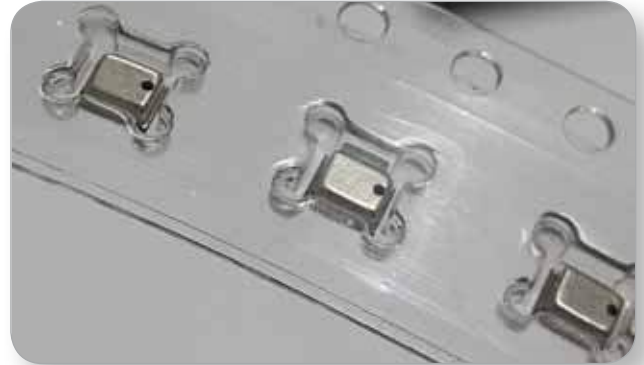

Applications

- Pressure sensor for mobile devices (*smart phones, smart watches, tablets*)
- Indoor and outdoor navigation
- Enhancement of GPS navigation
- Altimeter and barometer for portable devices
- Weather station equipment
- Leisure and sports
- Hard Disk Drive (HDD)
- Weather forecast

Features

- 260 to 1260 mBar absolute pressure range
- Temperature measurement included
- Sleep State current <250nA (25°C)
- Temperature resolution: <0.003K/LSB
- 16bit pressure and temperature resolution
- Operation temperature: -40°C to +85 °C
- Absolute accuracy +/- 0.2 mbar/Relative accuracy +/- 0.1 mbar
- I²C interface
- Operating range 1.7 ~ 3.6V
- Small size package (2.0 x 2.5 x 1.0mm)
- 8-HCLGA package
- Fully Calibrated and Compensated
- Digital compensation via 18bit internal digital signal processor (DSP) running a correction algorithm



Overview

- The NPA 201 is an absolute pressure sensor with digital output for low cost applications.
- A miniature 2.0 x 2.5 x 1.0mm HCLGA package ideally suits it for portable electronics and space constrained applications.
- Low current consumption of 250nA during Shutdown (Sleep) mode is ideal for battery and other low-power applications.
- A wide operating temperature range from -40°C to +85°C fits well with demanding environmental requirements.
- NPA 201 employs a MEMS pressure sensor with a signal-conditioning IC to provide accurate pressure measurement from 260 to 1260 mBar.
- The NPA 201 was developed to compensate and calibrate resistive bridge sensors, but it can also provide a corrected temperature output using an internal sensor.
- The measured and corrected bridge values are provided at the digital output pins, through an I2C interface.
- Digital compensation of the signal offset, sensitivity, temperature, and non-linearity is accomplished via an 18bit internal digital signal processor (DSP) running a correction algorithm.
- Calibration coefficients are stored on-chip in highly reliable, nonvolatile, multiple-time programmable (MTP) memory.

Block Diagram

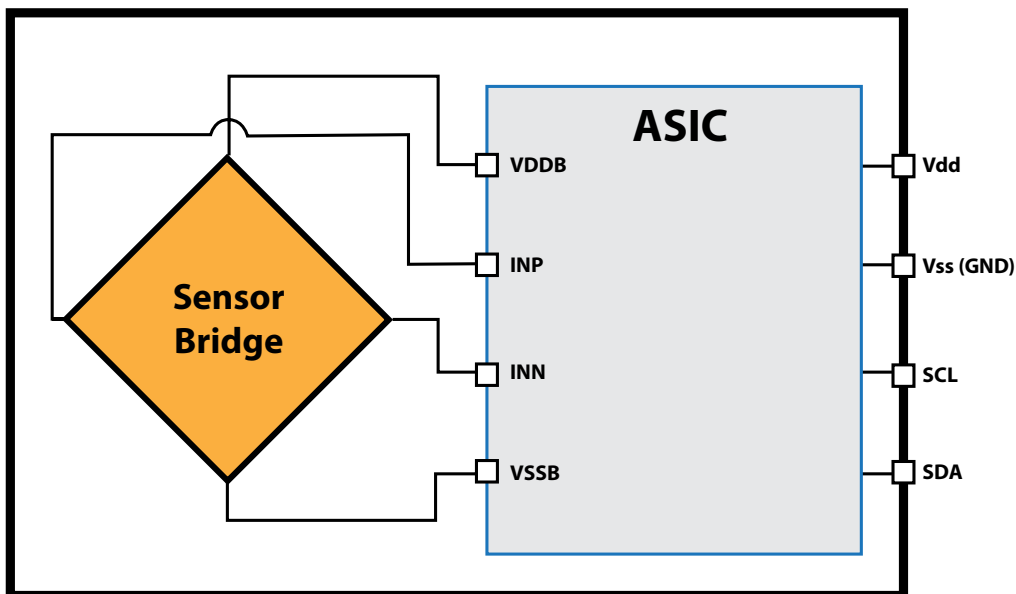

Figure 1 - Block Diagram

Pin Configuration

8 -HCLGA

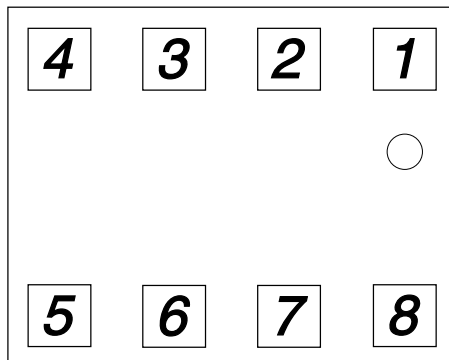

Figure 2 - PKG Diagram

Pin Description

PIN Number	PIN Name	Description	I/O
1	GND	Ground	ground
2	N/C	Not Connected	-
3	SDA	Data in/out for I ² C	I/O
4	SCL	Clock input for I ² C	I
5	N/C	Not Connected	-
6	VDD	Power supply	power
7	GND	Ground	ground
8	VDD	Power supply	power

Electrical Specifications

Symbol	Parameter	Limits			Unit	Remark
		Min	Typ	Max		
V _{DD}	Supply Voltage	1.7	-	3.6	V	
T _{op}	Operating Temperature	-40	-	85	°C	
T _{acc}	Full Accuracy Temperature	-20	-	80	°C	
I _{VDD}	Current Consumption	-	35	-	μA	Read time = 500ms
		-	20	250	nA	Sleep State, Idle Current, <85 C
P _{op}	Operating Pressure Range	260	-	1260	mBar	
P _{bit}	Pressure output data bits	-	16	-	bit	
P _{res}	Pressure resolution	-	0.015 (0.12)	-	mBar(m)	
T _{bit}	Temperature output data	-	16	-	bit	
T _{abs}	Absolute accuracy Temperature	-	± 1	-	°C	T= -20~+80 °C
	Total error band	-1		+1	%FS	
POWER UP						
T _{STA1}	Start-up Time			1	ms	VDD ramp up to interface communication
T _{STA2}				2.5	ms	VDD ramp up to analog operation
T _{WUP1}	Wake-up Time			0.5	ms	Sleep to Active State interface communication
T _{WUP2}				2	ms	Sleep to Active State analog operation
INTERFACE						
	I ² C Slave Address			0x27		Procedure for changing address is detailed in Application Guide AAS-910-290
f _{C,I2C}	I ² C Clock Frequency			3.4	MHz	

Absolute Maximum Ratings

Symbol	Parameter	Limits			Unit
		Min	Typ	Max	
V _{SS}	Voltage Reference	0	-	0	V
V _{dd}	Supply voltage	-0.4	-	3.63	V
P	Overpressure	-	-	20,000	mBar
V _{HBM1}	Electrostatic Discharge Tolerance – Human Body Model	-8	-	8	kV
T _{STOR}	Storage Temperature	-40	-	120	°C

Functional Description

I²C

In I²C Mode, each command is started as shown in Figure 3. Only the number of bytes that is needed for the command has to be sent. After the execution of a command (busy = 0) the expected data can be read as illustrated in Figure 5, or if no data are returned by the command the next command can be sent. The status can be read at any time as described in Figure 4.

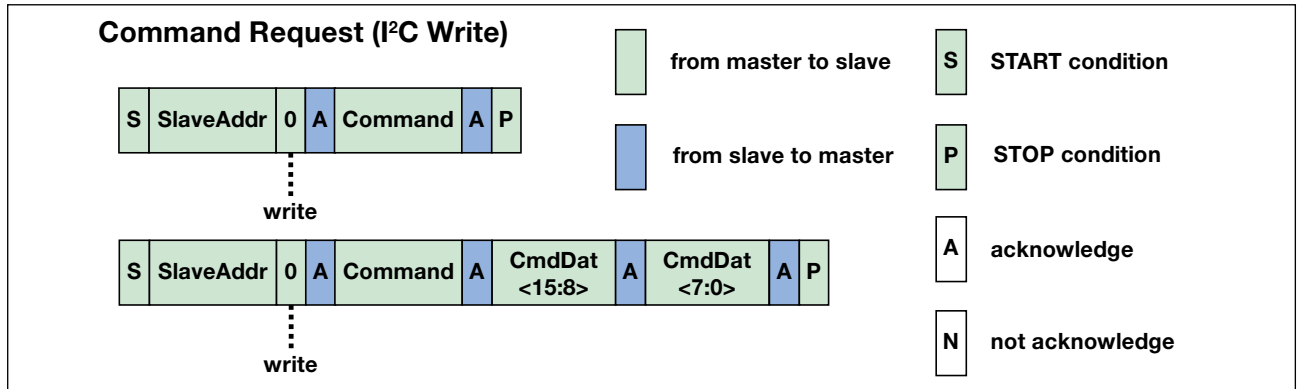

Figure 3 - I²C Command Request

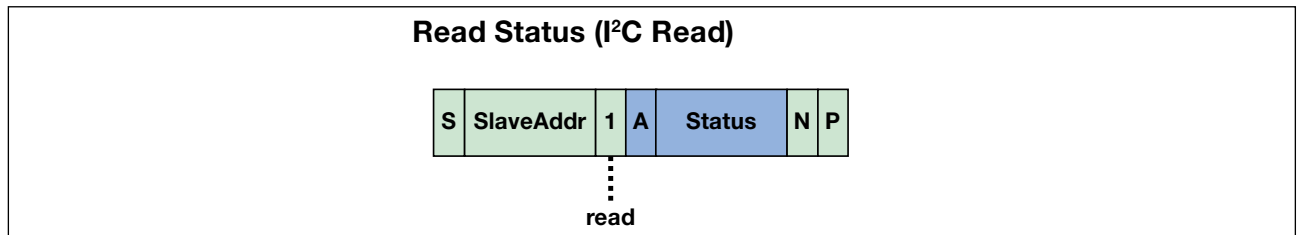

Figure 4 - I²C Read Status

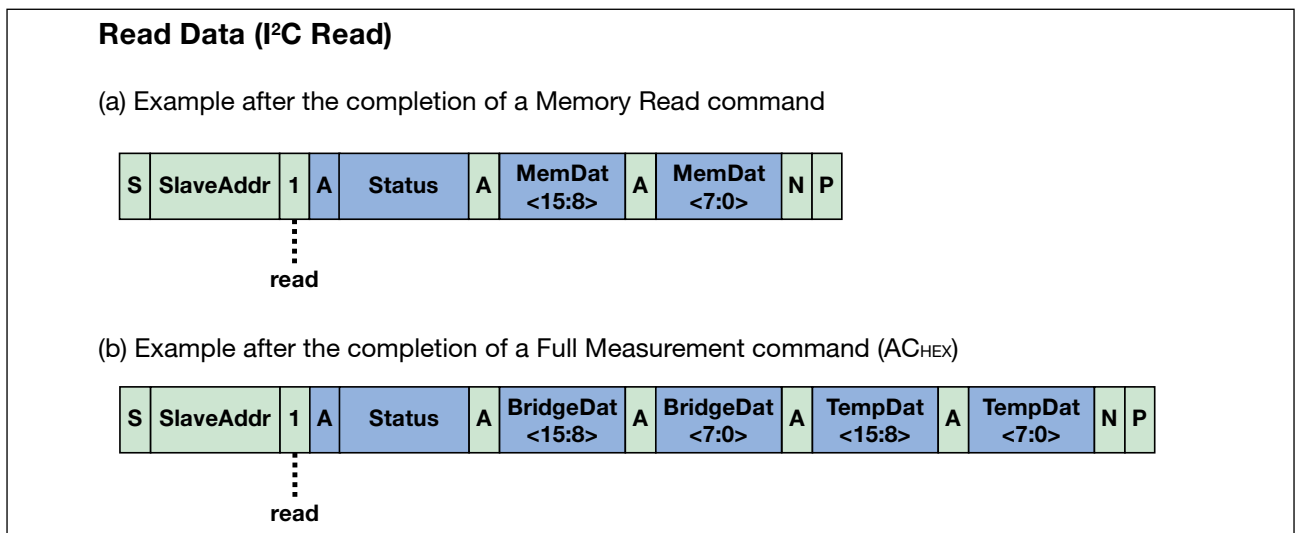

Figure 5 - I²C Read Data

All mandatory I²C-bus protocol features are implemented. Optional features like clock stretching, 10bit slave address, etc., are not supported by the NPA 201's interface.

In I²C-High Speed Mode, a command consists of a fixed length of three bytes.

I²C Commands

The I²C commands supported by the NPA 201 are listed in the table below.

The command to read an address in the user memory is the same as its address.

Command (Byte)	Returns	Description
AC _{HEX}	8 bit status byte + 16 bit corrected bridge pressure data + 16 bit corrected internal temperature data	Measure Triggers full measurement cycle and calculation and storage of data in interface (configurations from MTP). Minimum Read time = 20ms - Convert formula - Temperature = TempData/65535*(85+40) -40 Pressure = BridgeData/65535*(1260-260) +260

Calculating Absolute Altitude

With the measured pressure p and the pressure at sea level p_0 e.g. 1013.25 mBar. The altitude in meters can be calculated with the international formula.

$$\text{altitude} = 44330 * \left(1 - \left(\frac{p}{p_0} \right)^{\frac{1}{5.255}} \right)$$

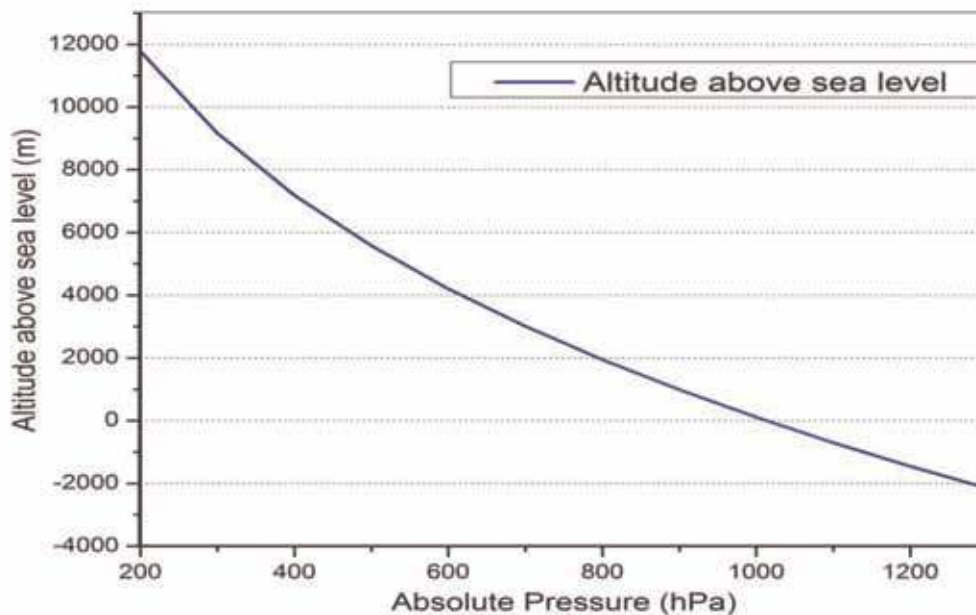
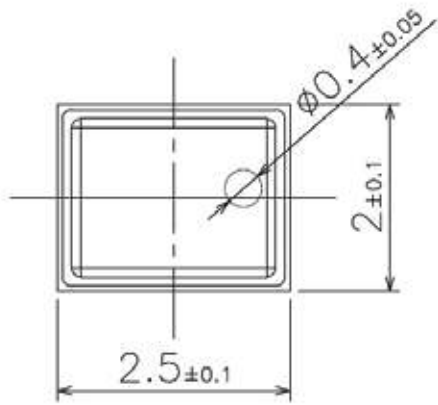

Figure 6 - Altitude above sea level

Mechanical Data

Mechanical Data (unit: mm)



<Top View>

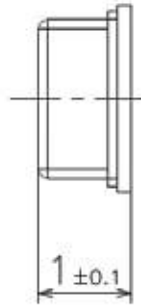

<Side View>

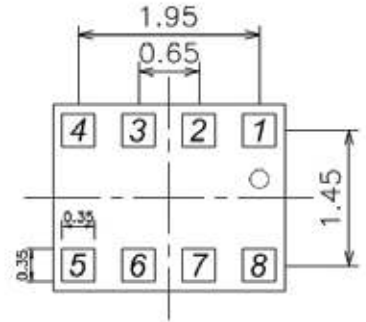

<Bottom View>

Pin No.	Function	Pin No.	Function
1	GND	5	N/C
2	N/C	6	VDD
3	SDA	7	GND
4	SCL	8	VDD

PCB Layout Footprint (unit: mm)

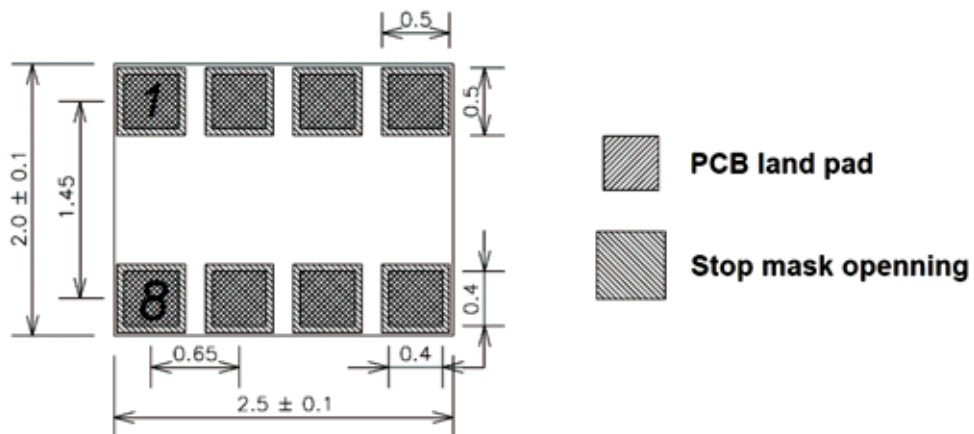

Application Information

Application Note

The pull up resistors (R1, R2) of two line serial bus are recommended to be around 2.2~10K ohm. VDD is recommended 1.7 ~ 3.6V. Pull up voltage should be use VDD.

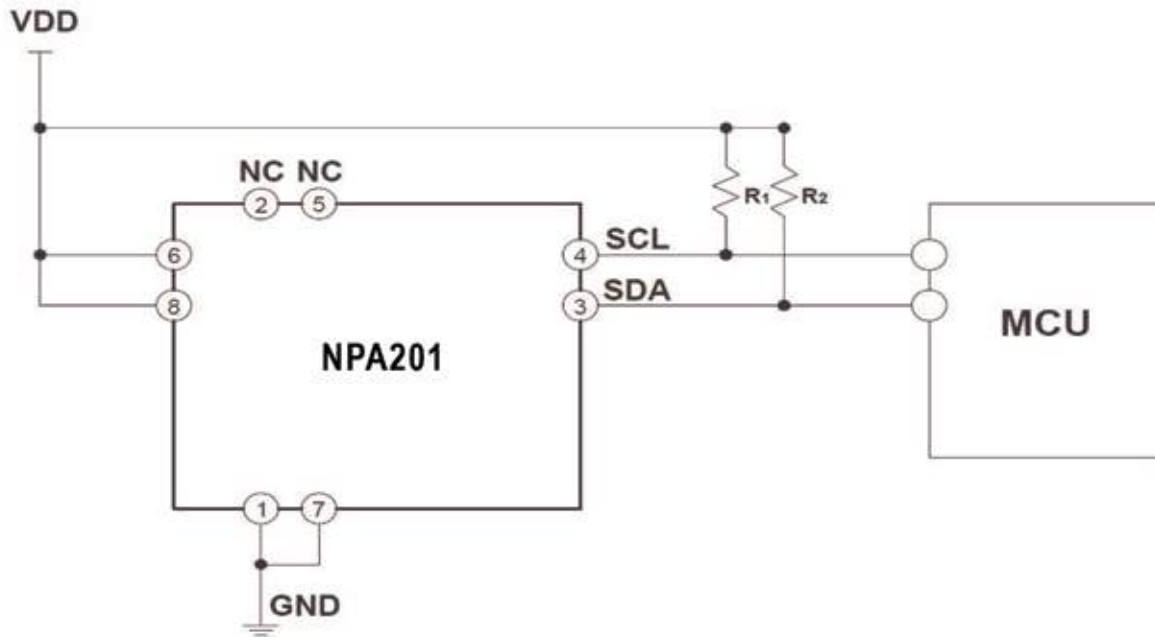

Figure 7 - Hardware pin connection diagram

Reflow Profile

* Standard Reflow Soldering Condition

Reference	J-STD-020-C, J-STD-033		
Maximum Peak Temperature	260°C		
Moisture Sensitivity Level	MSL 3		
Bake Condition		Exposure Time > 72 hours	Exposure Time < 72 hours
	Bake @ 125°C	9 hours	7 hours
	Bake @ 90°C, < 5% RH	33 hours	23 hours
	Bake @ 40°C, < 5% RH	13 days	9 days

- Recommended Solder Reflow

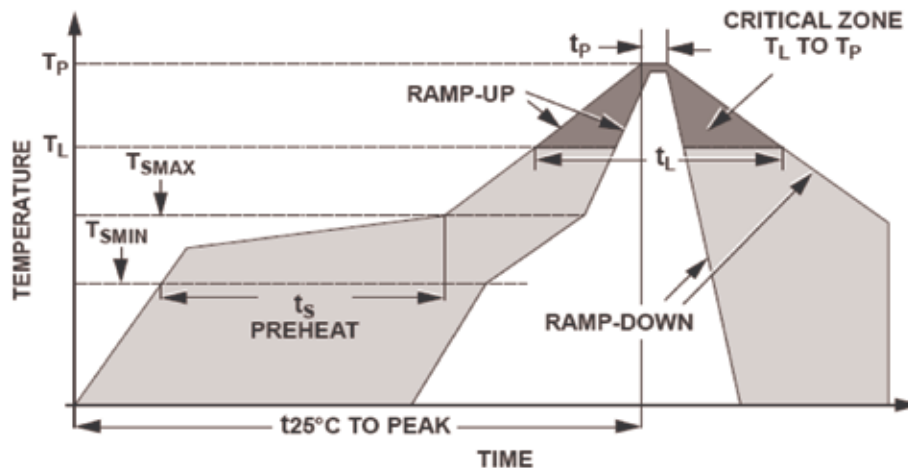

Profile Feature	Pb-Free Assembly
Average ramp-up rate (T_{SMAX} to T_p)	3°C/second max.
Preheat <ul style="list-style-type: none"> - Temperature Min. (T_{SMIN}) - Temperature Max. (T_{SMAX}) - Time (T_{SMIN} to T_{SMAX}) (T_s) 	150°C 200°C 60 ~ 180 seconds
Time maintained above : <ul style="list-style-type: none"> - Temperature (T_L) - Time (t_L) 	217°C 60 ~ 150 seconds
Peak temperature (T_p)	260°C
Time within 5°C of actual peak temperature (T_p) ²	20 ~ 40 seconds
Ramp-down rate	6°C/second max.
Time 25°C to peak temperature	8 minutes max.



CAUTION

- If cleaning process is needed after reflow, you must attach Antipollution Tape.
 - Cleaner can flow into the Air Hole and damage the product.
- Do Not expose to ultrasonic processing or cleaning.
- High-Pressure Air Brush is NOT Allowed.
 - The Air Brush may Damage the Membrane and/or Dust Inflow.

Package Specifications

Carrier Tape Information I (unit: mm)

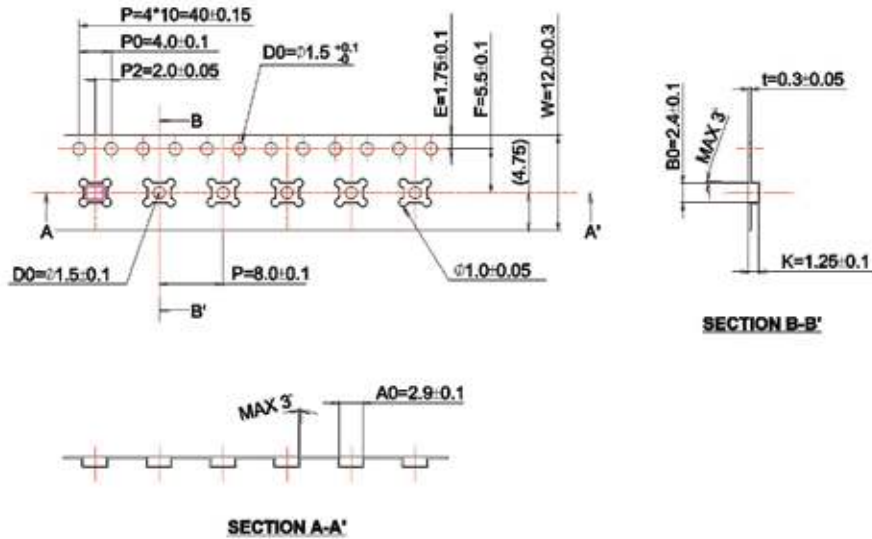

Carrier Tape Information II (unit: mm)

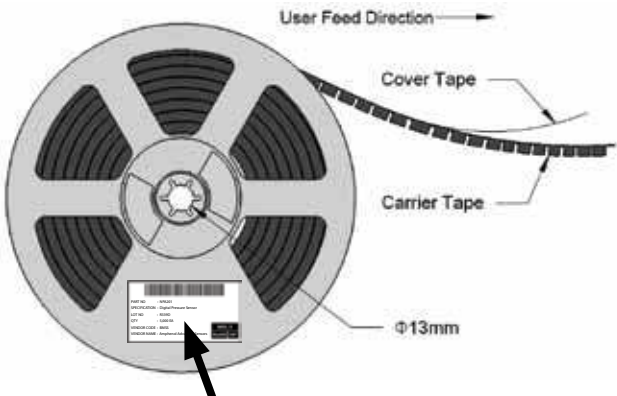



PART NO : NPA201
 SPECIFICATION : Digital Barometric Pressure Sensor
 LOT NO : XXXX
 QTY : 5,000 EA
 VENDOR NAME : Amphenol Advanced Sensors

MSL 3
RoHS HF

- Notes:**
1. MSL 3 (IPC/JEDEC J-STD-020C)
 2. REEL DIAMETER : 330 ± 1 mm
 3. Quantity Per Reel : 5,000EA
 4. Label : external package & reel

Reel Information (unit: mm)

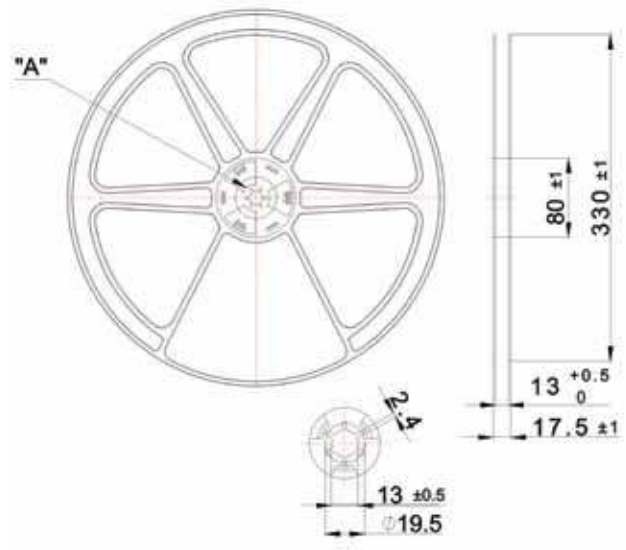

Ordering Information

Part Number : NPA 201

Conditions of Storage & Bake

- Use this product within 6 months after receipt.
- The unopened packaged parts should be stored from 5 to 35°C and 20 to 70% RH.
- Product used more than 6 months after receipt, must be inspected for humidity exposure before reflow solder. If baking is required, then bake product in heat-resistant trays. Do not bake in the packing materials (Base Tape, Reel Tape and Cover Tape).
- The product shall be stored in non-corrosive gas (N₂, Argon).
- Prevent damage to the product and packing materials by avoiding excessive mechanical shock, which includes, but is not limited to dropping the product or poking it with sharp objects.
- This product is applicable to MSL3 (Based on JEDEC Standard J-STD-020).
- After the packing opened, the product shall be stored at <30°C / <60% RH and the product shall be used within 168 hours.
- When the color of the indicator in the packing changed, the product shall be baked before soldering.
- Baking condition : See table on page 9 for complete details.

Warranty

Amphenol Advanced Sensors warrants its products against defects in material and workmanship for 12 months from the date of shipment. Products not subjected to misuse will be repaired or replaced. Amphenol Advanced Sensors reserves the right to make changes without further notice to any products herein. Amphenol Advanced Sensors makes no warranty, representation or guarantee regarding the suitability of its products for any particular application, nor does Amphenol Advanced Sensors assume any liability arising out of the application or use of any product or circuit and specifically disclaims and all liability without limitation consequential or incidental damages. The foregoing warranties are exclusive and in lieu of all other warranties, whether written, oral, implied or statutory. No implied statutory warranty of merchantability or fitness for particular purpose shall apply.

Amphenol

Advanced Sensors

www.amphenol-sensors.com

© 2016 Amphenol Corporation. All Rights Reserved. Specifications are subject to change without notice.
Other company names and product names used in this document are the registered trademarks or
trademarks of their respective owners.

AAS-920-649C - 02/2016