

3mm (T1) Package Discrete LED YELLOW, Ultra Bright



3UYC-X

- ◆ Industry Standard 3mm (T1) Package
- ◆ RoHS Compliant
- ◆ Water Clear Lens
- ◆ Available in Flange (F) and Shouldered (S) Lead Frame styles
- ◆ Up to 300 mcd Luminous Intensity at 20 mA
- ◆ Ideal for Back Lighting, Status Indication, and Display
- ◆ Recommended for Bivar Flexible Light Pipe assemblies

Bivar 3mm T1 Package Ultra Bright LED is ideal for those applications where intensive ambient lighting exists such as Back Lighting, Signage, and Sunlight Readable applications. Bivar offers water clear LED lens for maximum light output. The Flanged LED is ideal for Panel Mount Clip & Ring assemblies. The Shouldered Lead frame LED is ideal for vertical spacer assemblies without lead bends and also has a built in strain relief feature which is ideal for right angle holder assemblies that require lead bends.

Part Number	Material	Emitted Color	Peak. Wavelength λ_p (nm) TYP.	Lens Appearance	Viewing Angle
3UYC-F	AlGaInP	YELLOW	590nm	Water Clear	20°
3UYC-S				Water Clear	30°

Part Number Designation

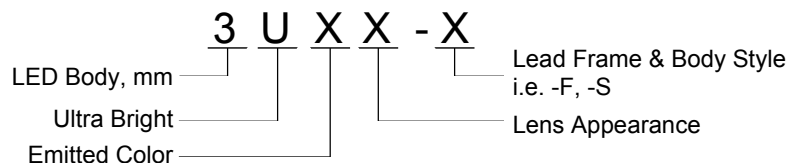

Bivar reserves the right to make changes at any time without notice.

3mm (T1) Package Discrete LED YELLOW, Ultra Bright



Outline Dimensions

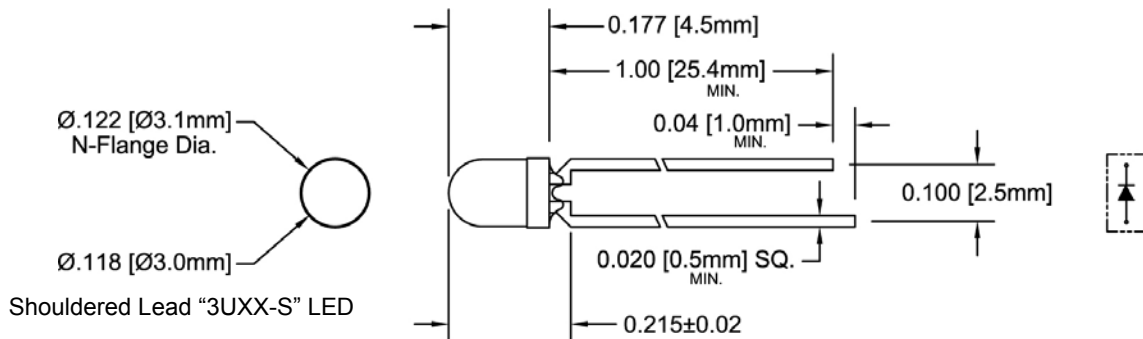
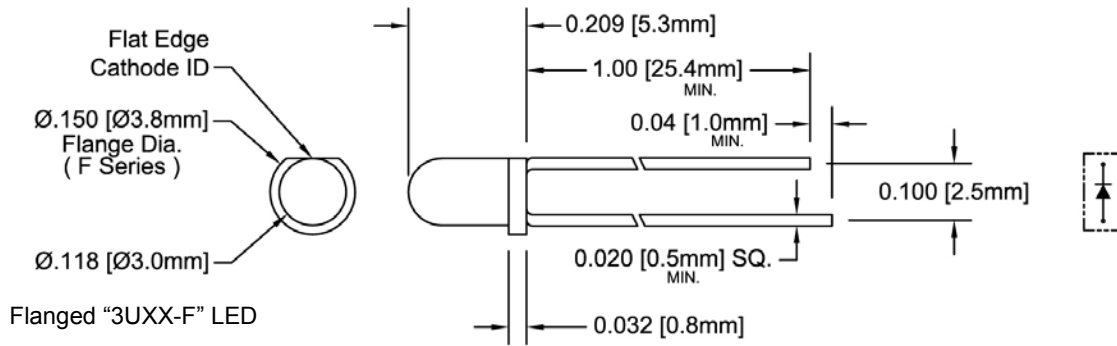

Recommended Mounting

Hole Size = $\text{Ø}0.032^{+.003}_{-.002}$

Outline Drawings Notes:

1. All dimensions are in inches [millimeters].
2. Standard tolerance: ± 0.010 " unless otherwise noted.
3. Tolerance of overall epoxy outline: ± 0.020 " unless otherwise noted.
4. Epoxy meniscus may extend to 0.060" max.

Bivar reserves the right to make changes at any time without notice.

3mm (T1) Package Discrete LED YELLOW, Ultra Bright



Absolute Maximum Ratings

T_A = 25°C unless otherwise noted

Power Dissipation	85 mW
Forward Current (DC)	30 mA
Peak Forward Current ¹	150 mA
Reverse Voltage	5 V
Operating Temperature Range	-25 ~ +85°C
Storage Temperature Range	-30 ~ +100°C
Lead Soldering Temperature (3 mm from the base of the epoxy bulb) ²	260°C

Notes: 1. 10% Duty Cycle, Pulse Width ≤ 0.1 msec. 2. Solder time less than 5 seconds at temperature extreme.

Electrical / Optical Characteristics

T_A = 25°C & I_F = 20 mA unless otherwise noted

Part Number	Forward Voltage (V) ¹			Recommend Forward Current (mA)			Reverse Current (μA)	Dominant Wavelength (nm) ²			Luminous Intensity I _v (mcd)			Viewing Angle 2Θ ½ (deg)
	MIN	TYP	MAX	MIN	TYP	MAX	MAX	MIN	TYP	MAX	MIN	TYP	MAX	TYP
3UYC-F	/	2.0	2.4	/	20	/	100	/	/	/	/	300	/	20
3UYC-S	/	2.0	2.4	/	20	/	100	/	/	/	/	300	/	30

Notes: 1. Tolerance of forward voltage : ±0.05V. 2. Tolerance of dominant wavelength : ±1.0nm.

Bivar reserves the right to make changes at any time without notice.

3mm (T1) Package Discrete LED YELLOW, Ultra Bright



Typical Electrical / Optical Characteristics

$T_A = 25^\circ\text{C}$ unless otherwise noted

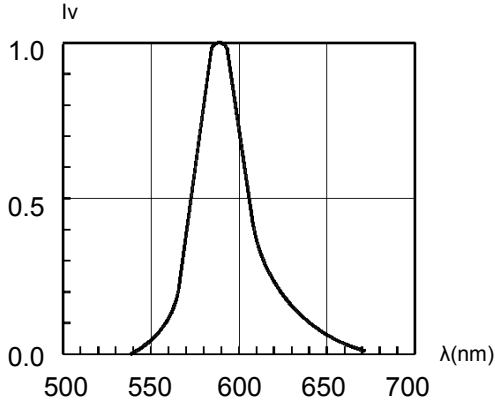

Fig. 1 Relative Luminous Intensity vs. Wavelength @ 20mA

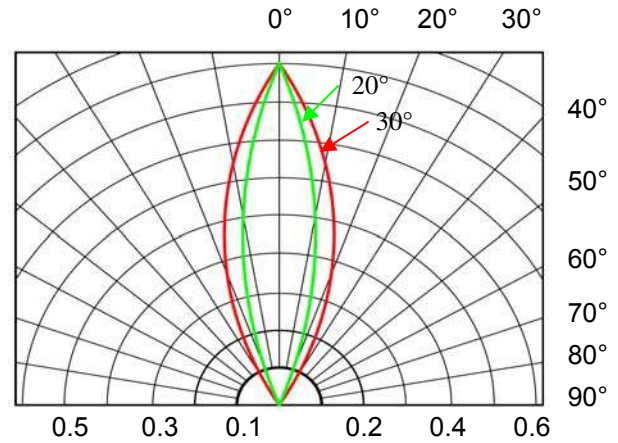

Fig. 2 Directivity Radiation Diagram

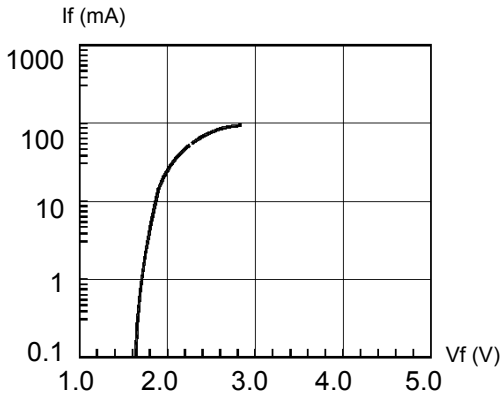

Fig. 3 Forward Current vs. Forward Voltage

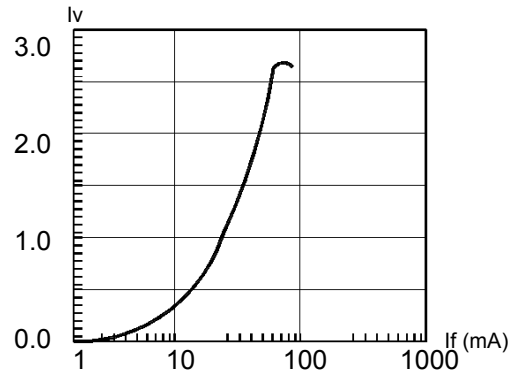

Fig. 4 Relative Luminous Intensity vs. Forward Current Normalize @ 20 mA

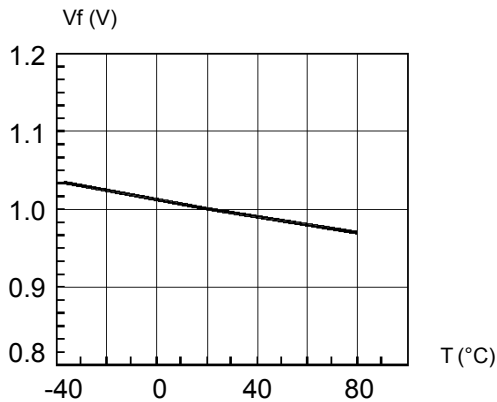

Fig. 5 Forward Voltage vs. Temperature

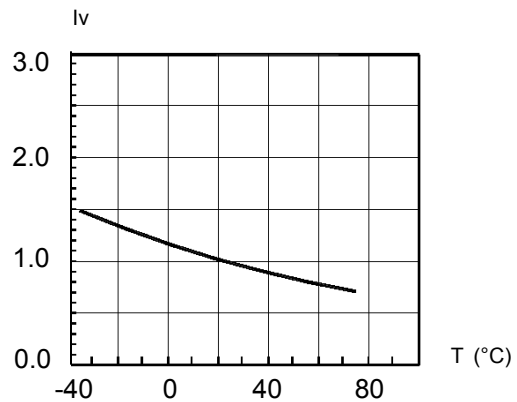

Fig. 6 Relative Luminous Intensity vs. Temperature

Bivar reserves the right to make changes at any time without notice.

3mm (T1) Package Discrete LED YELLOW, Ultra Bright



Recommended Soldering Conditions

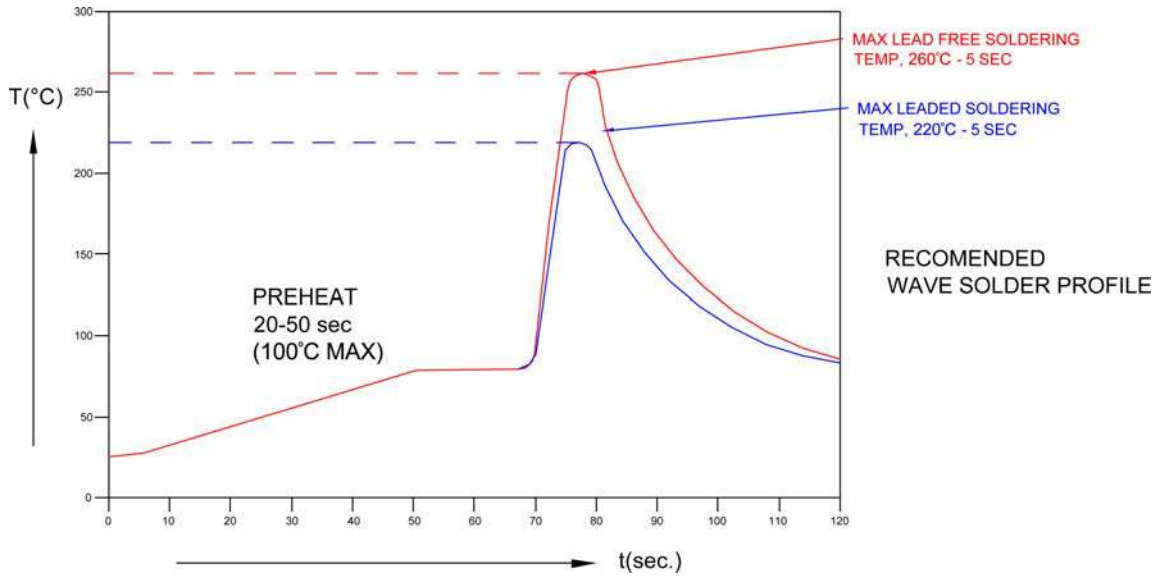

Recommended Lead Free Wave Soldering Profile	
Preheat Temperature: 100°C Max.	Peak Temperature: 260°C Max.
Preheat Time: 20 ~ 50 Seconds	Solder Time Above 217°C: 5 Seconds Max.
Note: Turn off top heater at preheat to prevent the lamp body directly exposed to the heat source.	

Packaging and Labeling Plan

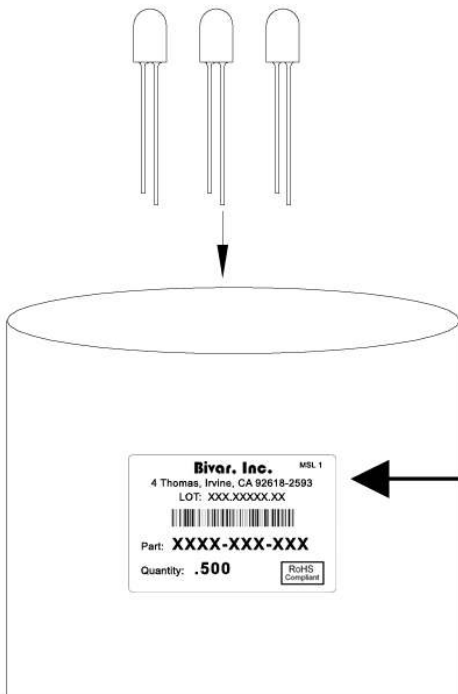

Bivar, Inc. MSL 1

4 Thomas, Irvine, CA 92618-2593
LOT: XXX.XXXXX.XX

Part: **XXXX-XXX-XXX**

Quantity: **.500**

RoHS
Compliant

Anti-Static Poly Bag with Desiccant
(500 pcs Max. per Bag)

Bivar reserves the right to make changes at any time without notice.