

### FEATURES

- InGaP HBT Technology
- High Efficiency:
  - 41% - Low Bias Mode
  - 39% - High Bias Mode
- Low Quiescent Current: 50 mA
- Low Leakage Current in Shutdown Mode:  $<1 \mu\text{A}$
- $V_{\text{REF}} = +2.85 \text{ V}$  (+2.75 V min over temp)
- Optimized for a 50  $\Omega$  System
- Low Profile Miniature Surface Mount Package: 1.56mm Max
- RoHS Compliant Package Option, 250 °C MSL-3

### APPLICATIONS

- Dual Mode 3GPP Wireless Handsets

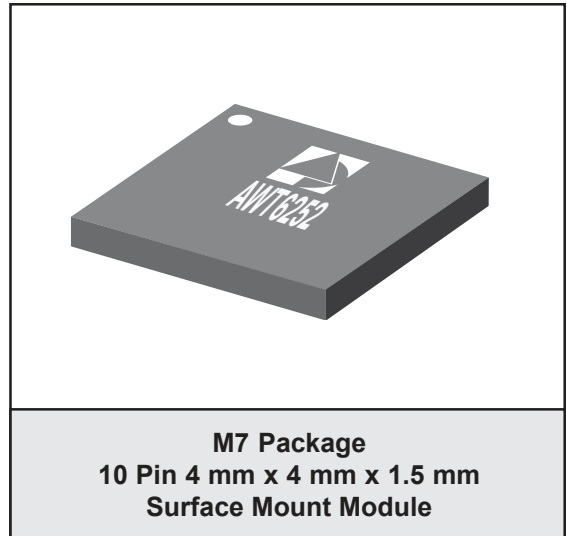

### PRODUCT DESCRIPTION

The AWT6252 meets the increasing demands for higher output power in 3GPP 1XRTT handsets. The PA module is optimized for  $V_{\text{REF}} = +2.85 \text{ V}$ , a requirement for compatibility with the Qualcomm® 6250 chipset. The device is manufactured on an advanced InGaP HBT MMIC technology offering state-of-the-art reliability, temperature stability, and ruggedness.

Selectable bias modes that optimize efficiency for different output power levels, and a shutdown mode with low leakage current, increase handset talk and standby time. The self-contained 4 mm x 4 mm x 1.5 mm surface mount package incorporates matching networks optimized for output power, efficiency, and linearity in a 50  $\Omega$  system.

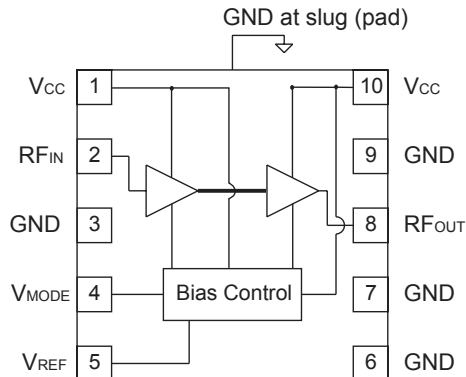

**Figure 1: Block Diagram**

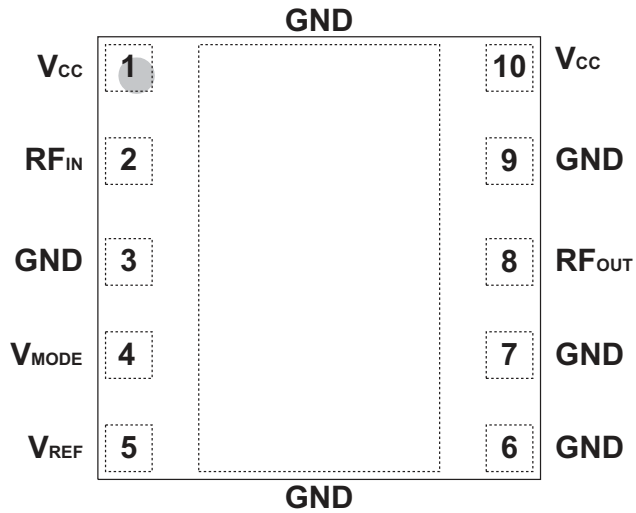

Figure 2: Pinout (X-ray Top View)

Table 1: Pin Description

PIN	NAME	DESCRIPTION
1	V <sub>CC</sub>	Supply Voltage
2	RF <sub>IN</sub>	RF Input
3	GND	Ground
4	V <sub>MODE</sub>	Mode Control Voltage
5	V <sub>REF</sub>	Reference Voltage
6	GND	Ground
7	GND	Ground
8	RF <sub>OUT</sub>	RF Output
9	GND	Ground
10	V <sub>CC</sub>	Supply Voltage

## ELECTRICAL CHARACTERISTICS

Table 2: Absolute Minimum and Maximum Ratings

PARAMETER	MIN	MAX	UNIT
Supply Voltage ( $V_{CC}$ )	0	+5	V
Mode Control Voltage ( $V_{MODE}$ )	0	+3.5	V
Reference Voltage ( $V_{REF}$ )	0	+3.5	V
RF Input Power ( $P_{IN}$ )	-	+10	dBm
Storage Temperature ( $T_{STG}$ )	-40	+150	°C

Stresses in excess of the absolute ratings may cause permanent damage. Functional operation is not implied under these conditions. Exposure to absolute ratings for extended periods of time may adversely affect reliability.

Table 3: Operating Ranges

PARAMETER	MIN	TYP	MAX	UNIT	COMMENTS
Operating Frequency (f)	1920	-	1980	MHz	
Supply Voltage ( $V_{CC}$ )	+3.2	+3.4	+4.2	V	
Reference Voltage ( $V_{REF}$ )	+2.75 0	+2.85 -	+2.95 +0.5	V	PA "on" PA "shut down"
Mode Control Voltage ( $V_{MODE}$ )	+2.5 0	+2.8 -	+3.1 +0.5	V	Low Bias Mode High Bias Mode
RF Output Power ( $P_{OUT}$ )	+27.0 <sup>(1)</sup>	+27.5	-	dBm	
Case Temperature ( $T_C$ )	-10	-	+90	°C	

The device may be operated safely over these conditions; however, parametric performance is guaranteed only over the conditions defined in the electrical specifications.

## Notes:

(1) For operation at  $T_C = +90$  °C and  $V_{CC} = +3.2$  V,  $P_{OUT}$  is derated by 0.5 dB.

**Table 4: Electrical Specifications**  
 (T<sub>C</sub> = +25 °C, V<sub>CC</sub> = +3.4 V, V<sub>REF</sub> = +2.85 V, 50 Ω system)

PARAMETER	MIN	TYP	MAX	UNIT	COMMENTS
Gain	24.5 22 17	26.5 24.5 20.5	29 27 24	dB	P <sub>OUT</sub> = +27.5 dBm, V <sub>MODE</sub> = 0 V P <sub>OUT</sub> = +16 dBm, V <sub>MODE</sub> = +2.85 V P <sub>OUT</sub> = +16 dBm, V <sub>CC</sub> = 1.5 V, V <sub>MODE</sub> = +2.85 V
ACLR1 at 5 MHz offset <sup>(1)</sup>	- - -	-43 -41 -46	-38 -38 -38	dBc	P <sub>OUT</sub> = +27.5 dBm, V <sub>MODE</sub> = 0 V P <sub>OUT</sub> = +16 dBm, V <sub>MODE</sub> = +2.85 V P <sub>OUT</sub> = +16 dBm, V <sub>CC</sub> = 1.5 V, V <sub>MODE</sub> = +2.85 V
ACLR2 at 10 MHz offset	- - -	-60 -62 -60	-50 -50 -48	dBc	P <sub>OUT</sub> = +27.5 dBm, V <sub>MODE</sub> = 0 V P <sub>OUT</sub> = +16 dBm, V <sub>MODE</sub> = +2.85 V P <sub>OUT</sub> = +16 dBm, V <sub>CC</sub> = 1.5 V, V <sub>MODE</sub> = +2.85 V
Power-Added Efficiency <sup>(1)</sup>	37 8.5 19	39 9.5 21.5	- - -	%	P <sub>OUT</sub> = +27.5 dBm, V <sub>MODE</sub> = 0 V P <sub>OUT</sub> = +16 dBm, V <sub>MODE</sub> = +2.85 V P <sub>OUT</sub> = +16 dBm, V <sub>CC</sub> = 1.5 V, V <sub>MODE</sub> = +2.85 V
Quiescent Current (I <sub>q</sub> )	-	53	65	mA	V <sub>MODE</sub> = +2.85 V
Reference Current	-	3.8	5	mA	through V <sub>REF</sub> pin
Mode Control Current	-	0.3	0.5	mA	through V <sub>MODE</sub> pin, V <sub>MODE</sub> = +2.85 V
Leakage Current	-	<1	5	μA	V <sub>CC</sub> = +4.2 V, V <sub>REF</sub> = 0 V, V <sub>MODE</sub> = 0 V
Noise in Receive Band	-	-139	-137	dBm/Hz	2110 MHz to 2170 MHz
Harmonics 2fo 3fo, 4fo	- - -	-45 -50	-30 -30	dBc	
Input Impedance	-	-	2:1	VSWR	
Spurious Output Level (all spurious outputs)	-	-	-70	dBc	P <sub>OUT</sub> ≤ +27.5 dBm In-band load VSWR < 5:1 Out-of-band load VSWR < 10:1 Applies over all voltage and temperature operating ranges
Load mismatch stress with no permanent degradation or failure	8:1	-	-	VSWR	V <sub>CC</sub> = +5.0 V, P <sub>IN</sub> = +5 dBm Applies over full operating temperature range

Notes:

(1) ACLR and Efficiency measured at 1950 MHz.

**Table 5: Electrical Specifications**  
**(T<sub>C</sub> = +25 °C, V<sub>CC</sub> = +3.4 V, V<sub>REF</sub> = +2.85 V, V<sub>MODE</sub> = +2.85 V, 50 Ω system)**

PARAMETER	MIN	TYP	MAX	UNIT	COMMENTS
Gain	24 22 17	26 24.5 20.5	28 27 24	dB	P <sub>OUT</sub> = +27.5 dBm P <sub>OUT</sub> = +16 dBm P <sub>OUT</sub> = +16 dBm, V <sub>CC</sub> = 1.5 V
ACLR1 at 5 MHz offset <sup>(1)</sup>	- - -	-41 -41 -46	-37 -38 -38	dBc	P <sub>OUT</sub> = +27.5 dBm, P <sub>OUT</sub> = +16 dBm, P <sub>OUT</sub> = +16 dBm, V <sub>CC</sub> = 1.5 V,
ACLR2 at 10 MHz offset	- - -	-56 -62 -60	-50 -50 -48	dBc	P <sub>OUT</sub> = +27.5 dBm P <sub>OUT</sub> = +16 dBm, P <sub>OUT</sub> = +16 dBm, V <sub>CC</sub> = 1.5 V
Power-Added Efficiency <sup>(1)</sup>	38 8.5 19	41 9.5 21.5	- - -	%	P <sub>OUT</sub> = +27.5 dBm P <sub>OUT</sub> = +16 dBm P <sub>OUT</sub> = +16 dBm, V <sub>CC</sub> = 1.5 V,
Quiescent Current (I <sub>q</sub> )	-	53	65	mA	
Reference Current	-	3.8	5	mA	through V <sub>REF</sub> pin
Mode Control Current	-	0.3	0.5	mA	through V <sub>MODE</sub> pin
Leakage Current	-	<1	5	μA	V <sub>CC</sub> = +4.2 V, V <sub>REF</sub> = 0 V, V <sub>MODE</sub> = 0 V
Noise in Receive Band	-	-138	-136	dBm/Hz	2110 MHz to 2170 MHz
Harmonics 2fo 3fo, 4fo	- - -	-45 -50	-30 -30	dBc	
Input Impedance	-	-	2:1	VSWR	
Spurious Output Level (all spurious outputs)	-	-	-70	dBc	P <sub>OUT</sub> ≤ +27.5 dBm In-band load VSWR < 5:1 Out-of-band load VSWR < 10:1 Applies over all voltage and temperature operating ranges
Load mismatch stress with no permanent degradation or failure	8:1	-	-	VSWR	V <sub>CC</sub> = +5.0 V, P <sub>IN</sub> = +5 dBm Applies over full operating temperature range

Notes:

(1) ACLR and Efficiency measured at 1950 MHz.

**APPLICATION INFORMATION**

To ensure proper performance, refer to all related Application Notes on the ANADIGICS web site: <http://www.anadigics.com>

**Shutdown Mode**

The power amplifier may be placed in a shutdown mode by applying logic low levels (see Operating Ranges table) to both the  $V_{REF}$  and  $V_{MODE}$  voltages.

**Bias Modes**

The power amplifier may be placed in either a Low Bias mode or a High Bias mode by applying the appropriate logic level (see Operating Ranges table) to the  $V_{MODE}$  voltage. The Bias Control table lists the recommended modes of operation for various applications.

**Table 6: Bias Control**

APPLICATION	P <sub>OUT</sub> LEVELS	BIAS MODE	V <sub>REF</sub>	V <sub>MODE</sub>	V <sub>CC</sub>
CDMA - low power	≤+16dBm	Low	+2.85 V	+2.85 V	≥ +1.5
CDMA - high power	>+16 dBm	High	+2.85 V	0 V	+3.4
Shutdown	-	Shutdown	0 V	0 V	-

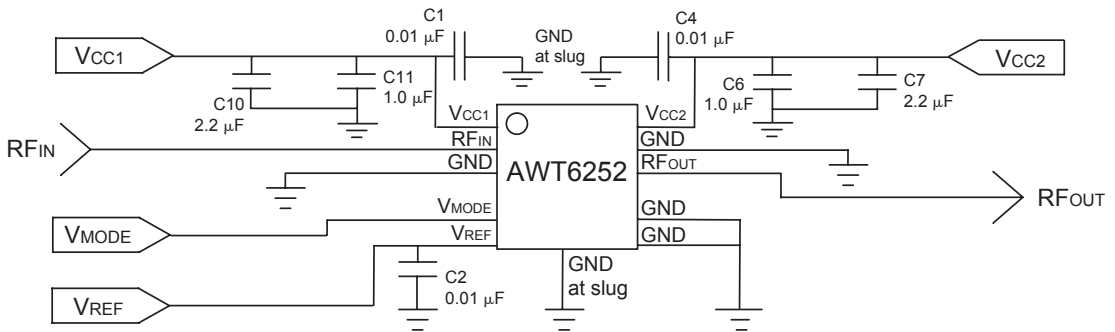

**Figure 3: Application Circuit Schematic**

PACKAGE OUTLINE

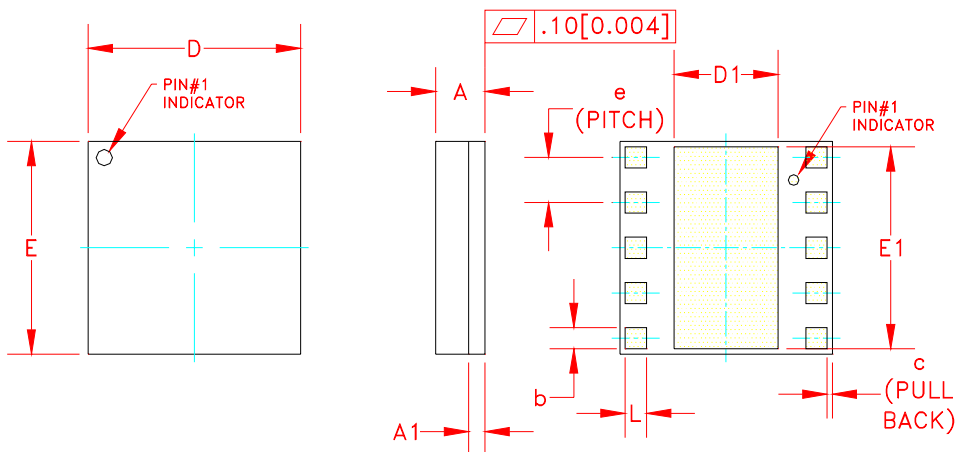

	MILLIMETERS			INCHES			NOTE
	MIN.	NOM.	MAX.	MIN.	NOM.	MAX.	
A	1.26	1.41	1.56	0.049	0.055	0.061	—
A1	—	0.30	—	—	0.012	—	—
b	0.35	—	0.60	0.013	—	0.024	3
c	—	0.10	—	—	0.004	—	—
D	3.88	4.00	4.12	0.152	0.157	0.162	—
D1	1.90	—	2.20	0.075	—	0.086	—
E	3.88	4.00	4.12	0.152	0.157	0.162	—
E1	3.75	—	3.85	0.148	—	0.152	—
e	—	0.85	—	—	0.033	—	3
L	0.35	—	0.60	0.013	—	0.024	3

NOTES:

1. CONTROLLING DIMENSIONS: MILLIMETERS
2. UNLESS SPECIFIED TOLERANCE=±0.076[0.003].
3. PADS (INCLUDING CENTER) SHOWN UNIFORM SIZE FOR REFERENCE ONLY. ACTUAL PAD SIZE AND LOCATION WILL VARY WITHIN MIN. AND MAX. DIMENSIONS ACCORDING TO SPECIFIC LAMINATE DESIGN.

Figure 4: M7 Package Outline - 10 Pin 4 mm x 4 mm x 1.5 mm Surface Mount Module

TOP BRAND



NOTES:

1. ANADIGICS LOGO SIZE: X=0.040±0.010 Y=0.048±0.010
2. PART # AWT6252
3. YEAR AND WORK WEEK: YYWW: YY = YEAR, WW = WORK WEEK
4. LOT - WAFER I.D.: LLLLL - SS = WAFER/LOT I.D.
5. PIN 1 INDICATOR: MOLD NOTCH -or- INK DOT
6. BOM # BBB
7. COUNTRY CODE: CCCCC
8. TYPE : ELITE  
SIZE : AS LARGE AS POSSIBLE  
LASER MARKED

Figure 5: Branding Specification

TOP BRAND



**NOTES:**

- 1. ANADIGICS LOGO SIZE: X=0.040±0.010 Y=0.048±0.010
- 2. PART # AWT6252R
- 3. YEAR AND WORK WEEK: YYWW: YY = YEAR, WW = WORK WEEK
- 4. LOT - WAFER I.D.: LLLLL - SS = WAFER / LOT I.D.
- 5. PIN 1 INDICATOR: MOLD NOTCH -or- INK DOT
- 6. BOM # BBB
- 7. COUNTRY CODE: CCCCC
- 8. TYPE : ELITE  
SIZE : AS LARGE AS POSSIBLE  
LASER MARKED

**Figure 6: Branding Specification - RoHS Compliant Package**



COMPONENT PACKAGING

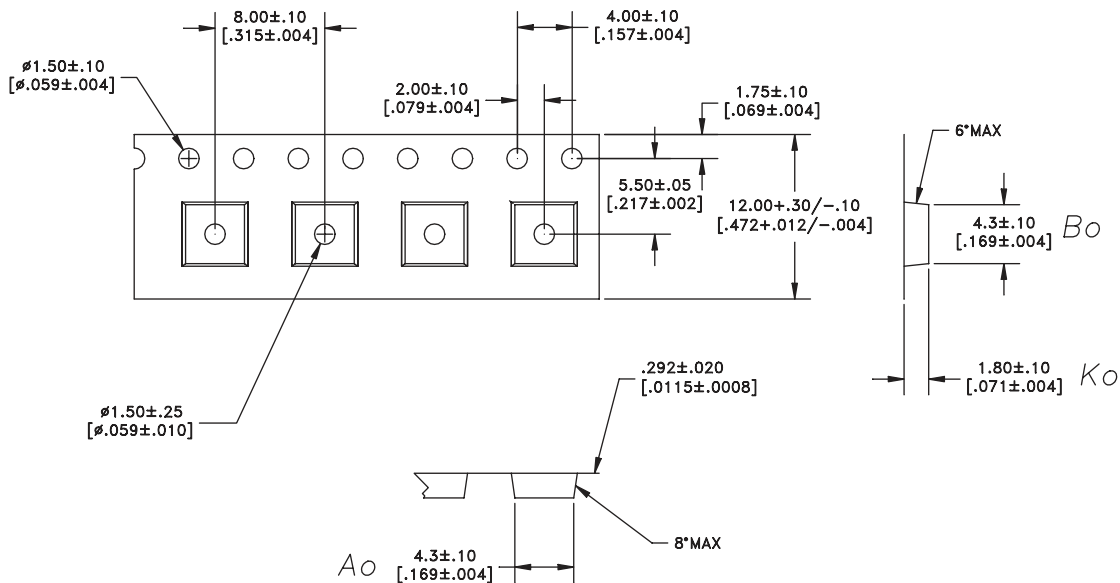

DIMENSIONS ARE IN MILLIMETERS [INCHES]  
STANDARD TOLERANCES

Figure 7: Tape & Reel Packaging

Table 7: Tape & Reel Dimensions

PACKAGE TYPE	TAPE WIDTH	POCKET PITCH	REEL CAPACITY	MAX REEL DIA
4 mm x 4 mm x 1.5 mm	12 mm	8 mm	2500	13"



NOTES



**ORDERING INFORMATION**

ORDER NUMBER	TEMPERATURE RANGE	PACKAGE DESCRIPTION	COMPONENT PACKAGING
AWT6252M7P8	-10 °C to +90 °C	10 Pin 4 mm x 4 mm x 1.5 mm Surface Mount Module	Tape and Reel, 2500 pieces per Reel
AWT6252RM7P8	-10 °C to +90 °C	RoHS Compliant 10 Pin 4 mm x 4 mm x 1.5 mm Surface Mount Module	Tape and Reel, 2500 pieces per Reel



**ANADIGICS, Inc.**  
 141 Mount Bethel Road  
 Warren, New Jersey 07059, U.S.A.  
 Tel: +1 (908) 668-5000  
 Fax: +1 (908) 668-5132

URL: <http://www.anadigics.com>  
 E-mail: [Mktg@anadigics.com](mailto:Mktg@anadigics.com)

**IMPORTANT NOTICE**

ANADIGICS, Inc. reserves the right to make changes to its products or to discontinue any product at any time without notice. The product specifications contained in Advanced Product Information sheets and Preliminary Data Sheets are subject to change prior to a product's formal introduction. Information in Data Sheets have been carefully checked and are assumed to be reliable; however, ANADIGICS assumes no responsibilities for inaccuracies. ANADIGICS strongly urges customers to verify that the information they are using is current before placing orders.

**WARNING**

ANADIGICS products are not intended for use in life support appliances, devices or systems. Use of an ANADIGICS product in any such application without written consent is prohibited.