

LOC		DIST		REVISIONS			
FR	LTR	DESCRIPTION	DATE	DRN	APVD		
B1		ECR-08-013486	28MAY2008	DZ	SY		

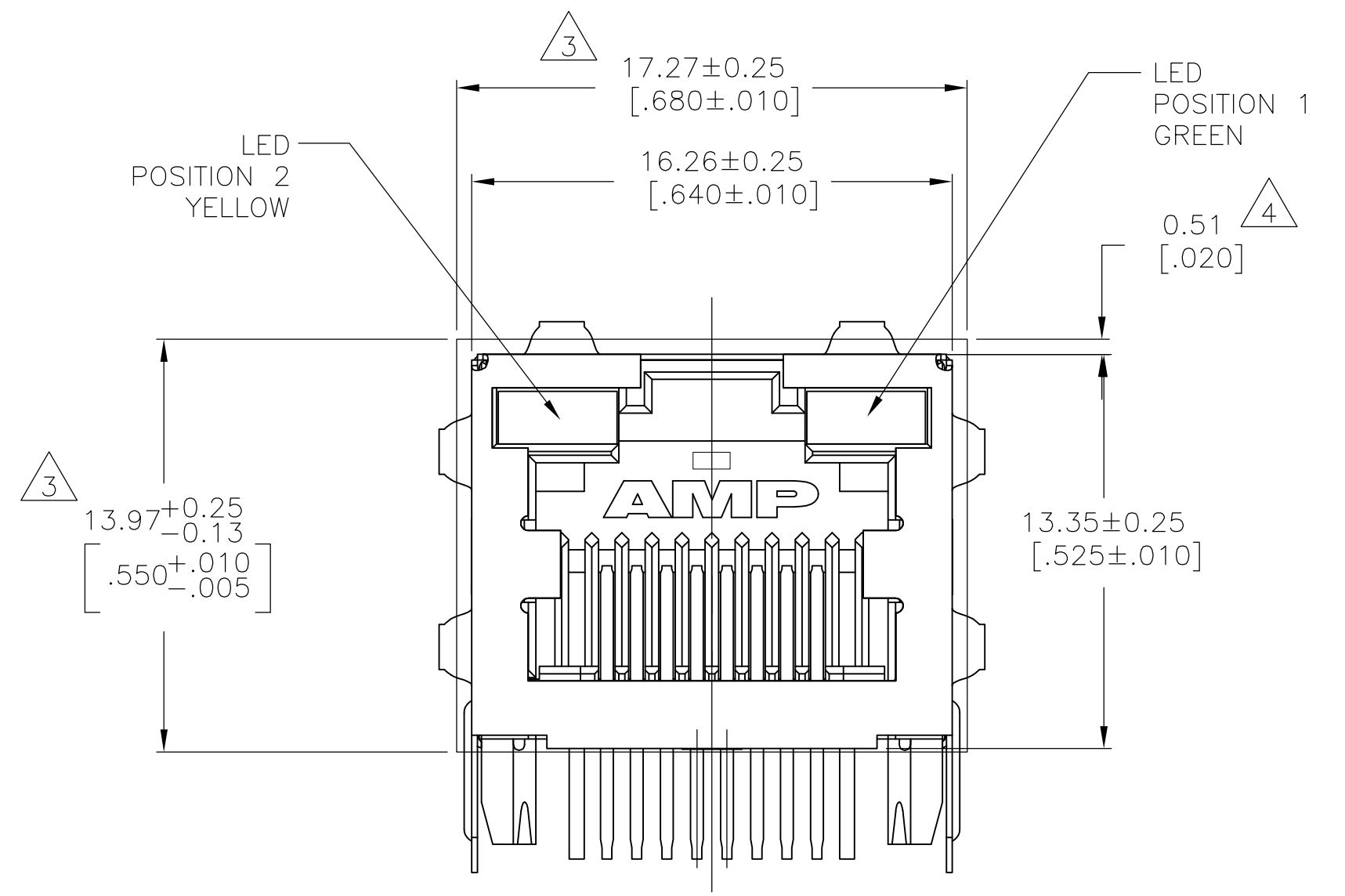

- 1 MATERIAL: HOUSING – HIGH TEMPERATURE THERMOPLASTIC, BLACK, UL94V-0.
 TERMINALS – 0.36[.014] THICK PHOS BRONZE PLATED WITH 3.81µm[.000150] MINIMUM THICK MATTE TIN IN SOLDER AREA. 1.27µm [.000050] MINIMUM GOLD IN LOCALIZED PLATE AREA. ENTIRE TERMINAL PLATED WITH 1.27µm [.000050] MINIMUM THICK NICKEL.
 SHIELD – 0.196[.0077] THICK COPPER ZINC ALLOY PREPLATED WITH 1.27µm[.000050] MINIMUM SATIN NICKEL WITH 2.03µm[.000080] MINIMUM TIN POST DIPPED ON PCB GROUND TABS.
 LIGHT EMITTING DIODE (LED) – DIFFUSED EPOXY LENS, 0.51 x 0.51[.020 x .020] CARBON STEEL WIREFRAME LEADS – 8.89µm[.000350] THICK Sn/Cu OVER 2.03µm[.000080] THICK Ag OVER 1.02µm[.000040] THICK Cu OVER 3.56µm[.000140] THICK Ni OVER 1.02µm[.000040] THICK Cu UNDERPLATE
- 2. JACK CAVITY CONFORMS TO FCC RULES AND REGULATIONS PART 68, SUBPART F.
- 3 SUGGESTED PANEL OPENING DIMENSIONS.
- 4 SUGGESTED CLEARANCE BETWEEN TOP OF CONNECTOR AND TOP PANEL OPENING.
- 5. THIS MODULAR JACK WITH INTEGRATED LED IS NOT IR REFLOW SOLDERING PROCESS COMPATIBLE.
- 6 MANUFACTURING DATE CODE: LOCATED APPROX. AS SHOWN.
 FIRST 2 DIGITS = LAST 2 DIGITS OF YEAR.
 NEXT 2 DIGITS = MANUFACTURING WORK WEEK.
 LAST DIGIT = DAY OF WEEK WITH SUNDAY = 1.

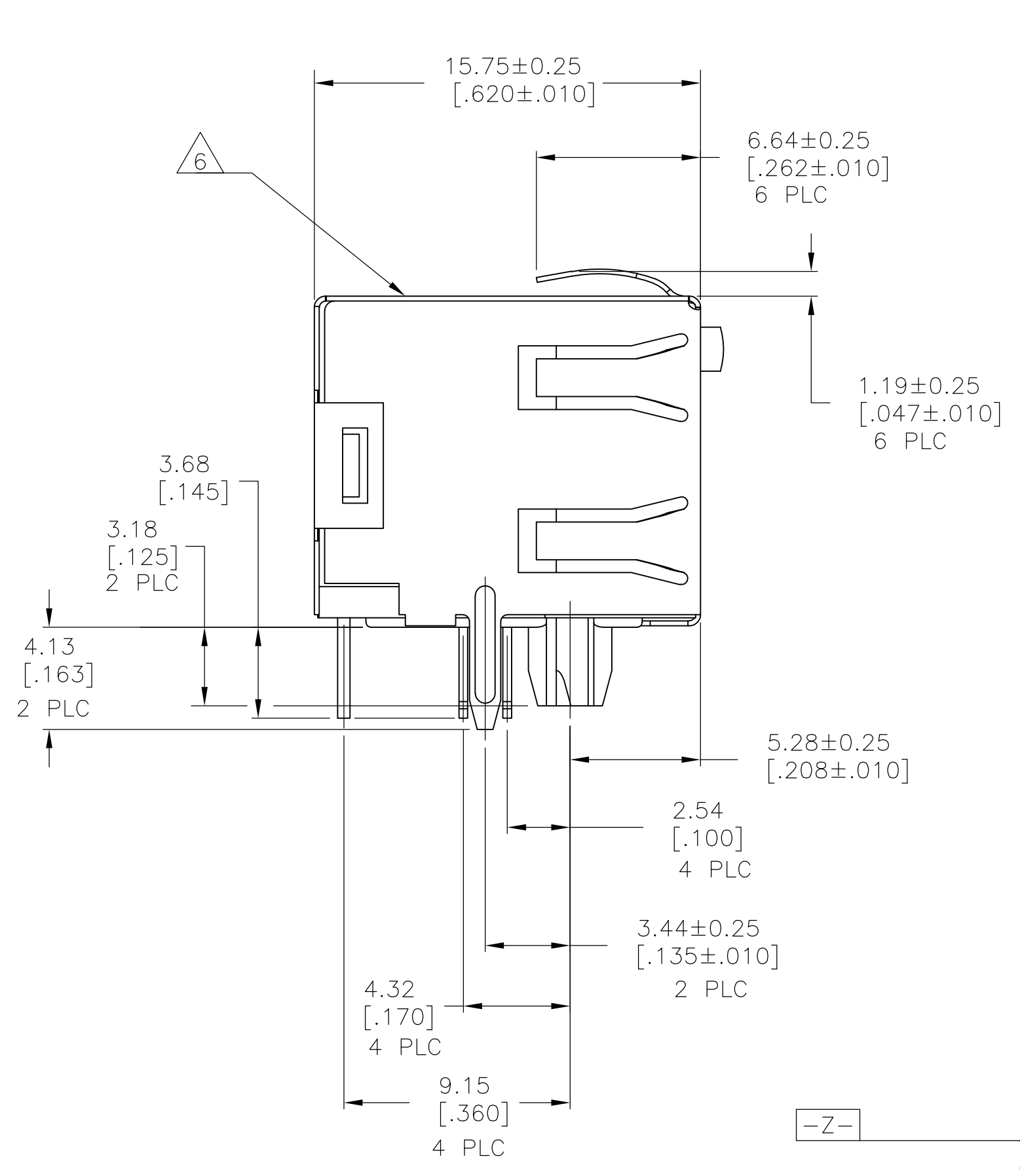
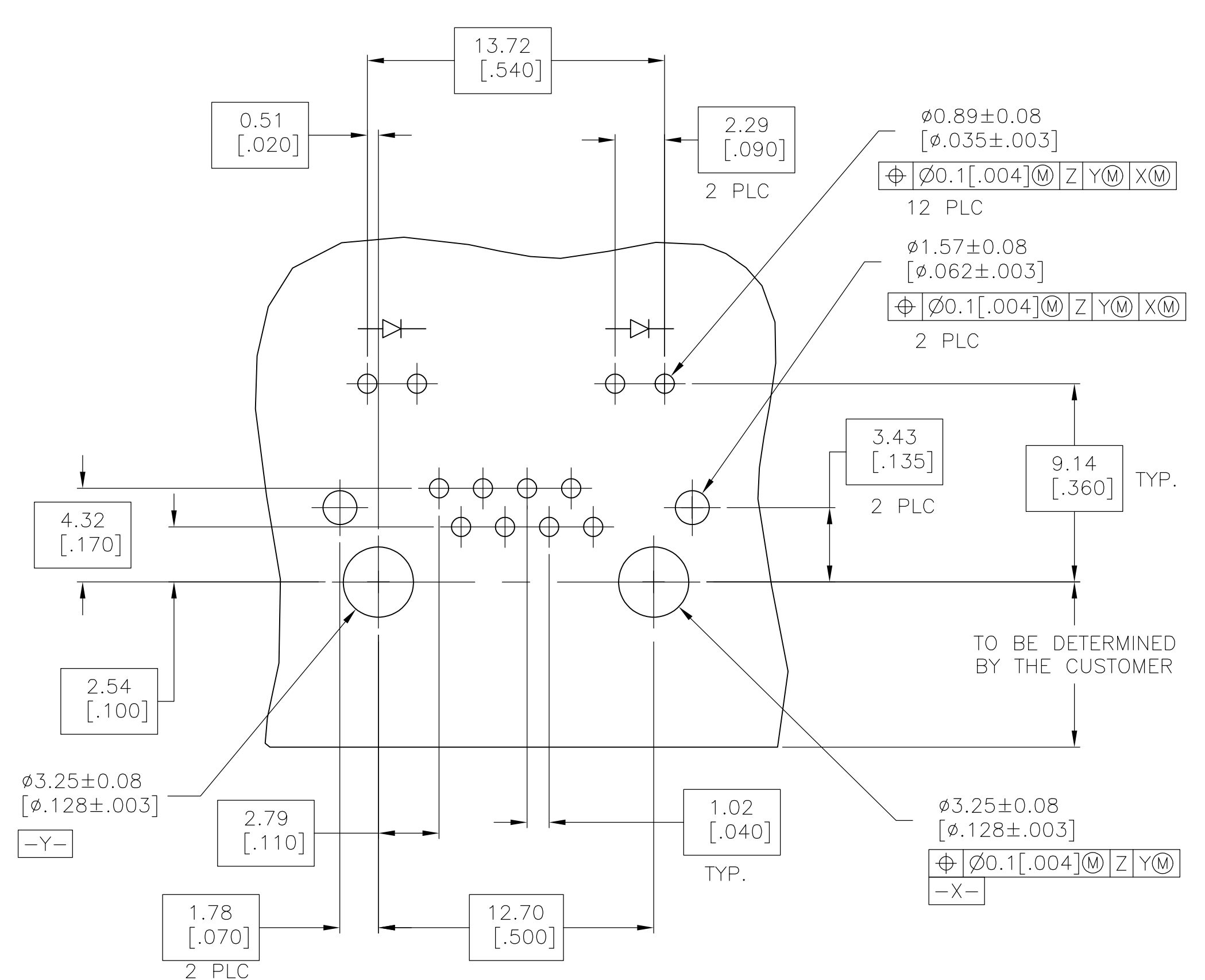

SUGGESTED PRINTED CIRCUIT BOARD LAYOUT (COMPONENT SIDE)

AS SHOWN	1761750-1
DESCRIPTION	PART NUMBER

THIS DRAWING IS A CONTROLLED DOCUMENT.		DWN R. GRZYBOWSKI 23AUG05		Tyco Electronics Corporation	
DIMENSIONS: mm [INCHES]		CHK J. WESTMAN 23AUG05		Harrisburg, Pa 17105-3608	
TOLERANCES UNLESS OTHERWISE SPECIFIED:		APPD S. FLICKINGER 23AUG05		NAME	
0 PLC ± -	1 PLC ± -	PRODUCT SPEC		INVERTED MODULAR JACK ASSEMBLY, 1X1, SHIELDED, PANEL GROUND, LED	
2 PLC ± 0.25[.01]	3 PLC ± 0.13[.005]	108-1163-4		SIZE	
4 PLC ± -	ANGLES ± -	APPLICATION SPEC		CAGE CODE DRAWING NO	
MATERIAL		114-2154		RESTRICTED TO	
FINISH		WEIGHT -		A1 00779 ©=1761750	
		CUSTOMER DRAWING		SCALE 4:1 SHEET 1 OF 1 REV B1	