

2 Watts ISP Series



- Single & Dual Regulated Outputs
- 2:1 Input Range
- SMD Package
- Industry Standard Pinout
- 1500 VDC Isolation
- -40 °C to +85 °C Operation
- 3 Year Warranty

Specification

Input

- Input Voltage Range • 12 V (9-18 VDC)
24 V (18-36 VDC)
- Input Reverse Voltage Protection • None
- Input Surge • 12 V: 22 VDC for 100 ms
24 V: 40 VDC for 100 ms

Output

- Output Voltage • See table
- Minimum Load • 10%⁽¹⁾
- Line Regulation • ±0.5%
- Load Regulation • ±1%, balanced load on dual outputs
- Setpoint Accuracy • ±3%/±5%, positive/negative output
- Ripple & Noise • 150 mV pk-pk 20 MHz bandwidth
- Temperature Coefficient • 0.03%/°C
- Short Circuit Protection • Continuous, automatic recovery

General

- Efficiency • See table
- Isolation Voltage • 1500 VDC
- Isolation Resistance • 10⁹ Ω
- Isolation Capacitance • 85 pF typical
- Switching Frequency • 300 kHz typical at nominal input, full load
- MTBF • >1 Mhrs to MIL-HDBK-217F at 25 °C, GB
- Recommended Solder Profile • IPC/JEDEC J-STD-020D.1

Environmental

- Operating Temperature • -40 °C to +70 °C, derate linearly to 0% load at +100 °C
- Storage Temperature • -55 °C to +125 °C
- Case Temperature • 100 °C max
- Cooling • Convection-cooled
- Lead Temperature • 240 °C, 0.06 in (1.5 mm) from case, 10 s

Notes

1. Operation at no load will not damage unit but it may not meet all specifications.

Input Voltage	Output Voltage	Output Current	Efficiency (typ)	Model Number ⁽⁹⁾
24 VDC	3.3 V	500 mA	72%	ISP2403A
	5.0 V	400 mA	76%	ISP2405A
	±12.0 V	±83 mA	78%	ISP2412

Mechanical Details

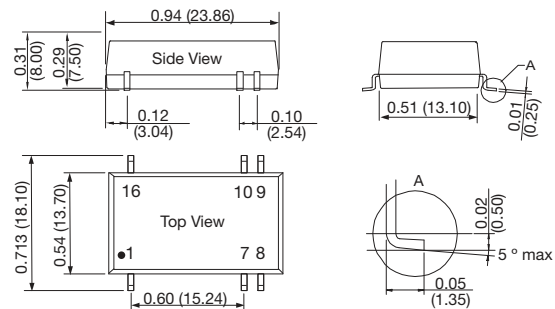

Recommended footprint

Top view grid: 0.1 x 0.1 in (2.54 x 2.54 mm)

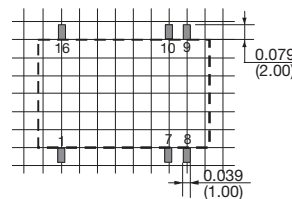

Pin	Single	Dual
1	-Vin	-Vin
7	N.C.	N.C.
8	N.C.	0V
9	+Vo	+Vo
10	0V	-Vo
16	Vin	Vin

N.C. Not connected

Notes

1. All dimensions in inches (mm)
2. Tolerance: ±0.010 (±0.25)
3. Pin tolerance: ±0.004 (±0.10 mm)
4. Weight: 0.011 lbs (5.2 g)
5. For optional tape & reel option add suffix -TR to the end of the p/n. Reel quantity = 200