



**MICROCHIP**

---

# **TC1047A Temperature-to-Voltage Converter PICtail™ Demo Board User's Guide**

---

**Note the following details of the code protection feature on Microchip devices:**

- Microchip products meet the specification contained in their particular Microchip Data Sheet.
- Microchip believes that its family of products is one of the most secure families of its kind on the market today, when used in the intended manner and under normal conditions.
- There are dishonest and possibly illegal methods used to breach the code protection feature. All of these methods, to our knowledge, require using the Microchip products in a manner outside the operating specifications contained in Microchip's Data Sheets. Most likely, the person doing so is engaged in theft of intellectual property.
- Microchip is willing to work with the customer who is concerned about the integrity of their code.
- Neither Microchip nor any other semiconductor manufacturer can guarantee the security of their code. Code protection does not mean that we are guaranteeing the product as "unbreakable."

Code protection is constantly evolving. We at Microchip are committed to continuously improving the code protection features of our products. Attempts to break Microchip's code protection feature may be a violation of the Digital Millennium Copyright Act. If such acts allow unauthorized access to your software or other copyrighted work, you may have a right to sue for relief under that Act.

---

Information contained in this publication regarding device applications and the like is provided only for your convenience and may be superseded by updates. It is your responsibility to ensure that your application meets with your specifications. MICROCHIP MAKES NO REPRESENTATIONS OR WARRANTIES OF ANY KIND WHETHER EXPRESS OR IMPLIED, WRITTEN OR ORAL, STATUTORY OR OTHERWISE, RELATED TO THE INFORMATION, INCLUDING BUT NOT LIMITED TO ITS CONDITION, QUALITY, PERFORMANCE, MERCHANTABILITY OR FITNESS FOR PURPOSE. Microchip disclaims all liability arising from this information and its use. Use of Microchip devices in life support and/or safety applications is entirely at the buyer's risk, and the buyer agrees to defend, indemnify and hold harmless Microchip from any and all damages, claims, suits, or expenses resulting from such use. No licenses are conveyed, implicitly or otherwise, under any Microchip intellectual property rights.

**Trademarks**

The Microchip name and logo, the Microchip logo, Accuron, dsPIC, KEELOQ, microID, MPLAB, PIC, PICmicro, PICSTART, PRO MATE, PowerSmart, rfPIC and SmartShunt are registered trademarks of Microchip Technology Incorporated in the U.S.A. and other countries.

AmpLab, FilterLab, Migratable Memory, MXDEV, MXLAB, SEEVAL, SmartSensor and The Embedded Control Solutions Company are registered trademarks of Microchip Technology Incorporated in the U.S.A.

Analog-for-the-Digital Age, Application Maestro, dsPICDEM, dsPICDEM.net, dsPICworks, ECAN, ECONOMONITOR, FanSense, FlexROM, fuzzyLAB, In-Circuit Serial Programming, ICSP, ICEPIC, Linear Active Thermistor, Mindi, MiWi, MPASM, MPLIB, MPLINK, PICKit, PICDEM, PICDEM.net, PICLAB, PICTail, PowerCal, PowerInfo, PowerMate, PowerTool, REAL ICE, rLAB, rfPICDEM, Select Mode, Smart Serial, SmartTel, Total Endurance, UNI/O, WiperLock and ZENA are trademarks of Microchip Technology Incorporated in the U.S.A. and other countries.

SQTP is a service mark of Microchip Technology Incorporated in the U.S.A.

All other trademarks mentioned herein are property of their respective companies.

© 2006, Microchip Technology Incorporated, Printed in the U.S.A., All Rights Reserved.

 Printed on recycled paper.

**QUALITY MANAGEMENT SYSTEM  
CERTIFIED BY DNV  
== ISO/TS 16949:2002 ==**

*Microchip received ISO/TS-16949:2002 certification for its worldwide headquarters, design and wafer fabrication facilities in Chandler and Tempe, Arizona, Gresham, Oregon and Mountain View, California. The Company's quality system processes and procedures are for its PICmicro® 8-bit MCUs, KEELOQ® code hopping devices, Serial EEPROMs, microperipherals, nonvolatile memory and analog products. In addition, Microchip's quality system for the design and manufacture of development systems is ISO 9001:2000 certified.*



# TC1047A TEMPERATURE-TO-VOLTAGE CONVERTER PICtail™ DEMO BOARD USER'S GUIDE

---

---

## Table of Contents

---

---

<b>Preface</b> .....	<b>1</b>
<b>Chapter 1. Product Overview</b>	
1.1 Introduction .....	5
1.2 What is the TC1047A Temperature-to-Voltage Converter PICtail™ Demo Board? .....	5
1.3 What the TC1047A Temperature-to-Voltage Converter PICtail™ Demo Board Kit includes .....	5
<b>Chapter 2. Installation and Operation</b>	
2.1 Introduction .....	7
2.2 Features .....	7
2.3 Getting Started .....	7
<b>Appendix A. Schematic and Layouts</b>	
A.1 Introduction .....	13
A.2 Board SchemAtic .....	14
A.3 Board - Top Layer .....	14
A.4 Board - Silk screen Layer .....	15
A.5 Board - Bottom Layer .....	15
<b>Appendix B. Bill Of Materials (BOM)</b>	
<b>Worldwide Sales and Service</b> .....	<b>18</b>

**NOTES:**



# TC1047A TEMPERATURE-TO-VOLTAGE CONVERTER PICtail™ DEMO BOARD USER'S GUIDE

## Preface

### NOTICE TO CUSTOMERS

All documentation becomes dated, and this manual is no exception. Microchip tools and documentation are constantly evolving to meet customer needs, so some actual dialogs and/or tool descriptions may differ from those in this document. Please refer to our web site ([www.microchip.com](http://www.microchip.com)) to obtain the latest documentation available.

Documents are identified with a “DS” number. This number is located on the bottom of each page, in front of the page number. The numbering convention for the DS number is “DSXXXXA”, where “XXXX” is the document number and “A” is the revision level of the document.

### INTRODUCTION

This chapter contains general information that will be useful to know before using the TC1047A Temperature-to-Voltage Converter PICtail™ Demo Board. Items discussed in this chapter include:

- Document Layout
- Conventions Used in this Guide
- Recommended Reading
- The Microchip Web Site
- Customer Support
- Document Revision History

### DOCUMENT LAYOUT

This document describes how to use the TC1047A Temperature-to-Voltage Converter PICtail™ Demo Board as a development tool. The manual layout is as follows:

- **Chapter 1. “Product Overview”** – Important information about the TC1047A Temperature-to-Voltage Converter PICtail™ Demo Board.
- **Chapter 2. “Installation and Operation”** – This chapter includes instructions on how to get started, with a detailed description of each of the board’s functions.
- **Appendix A. “Schematic and Layouts”** – Shows the schematic and layout diagrams for the TC1047A Temperature-to-Voltage Converter PICtail™ Demo Board.
- **Appendix B. “Bill Of Materials (BOM)”** – Lists the parts used to build the TC1047A Temperature-to-Voltage Converter PICtail™ Demo Board.

## CONVENTIONS USED IN THIS GUIDE

This manual uses the following documentation conventions:

### DOCUMENTATION CONVENTIONS

Description	Represents	Examples
<b>Arial font:</b>		
Italic characters	Referenced books	<i>MPLAB® IDE User's Guide</i>
	Emphasized text	...is the <i>only</i> compiler...
Initial caps	A window	the Output window
	A dialog	the Settings dialog
	A menu selection	select Enable Programmer
Quotes	A field name in a window or dialog	"Save project before build"
Underlined, italic text with right angle bracket	A menu path	<u><i>File&gt;Save</i></u>
Bold characters	A dialog button	Click <b>OK</b>
	A tab	Click the <b>Power</b> tab
N'Rnnnn	A number in verilog format, where N is the total number of digits, R is the radix and n is a digit.	4'b0010, 2'hF1
Text in angle brackets < >	A key on the keyboard	Press <Enter>, <F1>
<b>Courier New font:</b>		
Plain Courier New	Sample source code	#define START
	Filenames	autoexec.bat
	File paths	c:\mcc18\h
	Keywords	_asm, _endasm, static
	Command-line options	-Opa+, -Opa-
	Bit values	0, 1
	Constants	0xFF, 'A'
Italic Courier New	A variable argument	<i>file.o</i> , where <i>file</i> can be any valid filename
Square brackets [ ]	Optional arguments	mcc18 [options] <i>file</i> [options]
Curly brackets and pipe character: {   }	Choice of mutually exclusive arguments; an OR selection	errorlevel {0 1}
Ellipses...	Replaces repeated text	var_name [, var_name...]
	Represents code supplied by user	void main (void) { ... }

## RECOMMENDED READING

This user's guide describes how to use TC1047A Temperature-to-Voltage Converter PICtail™ Demo Board. The following Microchip documents are available and recommended as supplemental reference resources.

### TC1047A Data Sheet, "Precision Temperature-to-Voltage Converter" (DS21498)

This data sheet provides detailed information regarding the TC1047A device.

## THE MICROCHIP WEB SITE

Microchip provides online support via our web site at [www.microchip.com](http://www.microchip.com). This web site is used as a means to make files and information easily available to customers. Accessible by using your favorite Internet browser, the web site contains the following information:

- **Product Support** – Data sheets and errata, application notes and sample programs, design resources, user's guides and hardware support documents, latest software releases and archived software
- **General Technical Support** – Frequently Asked Questions (FAQs), technical support requests, online discussion groups, Microchip consultant program member listing
- **Business of Microchip** – Product selector and ordering guides, latest Microchip press releases, listing of seminars and events, listings of Microchip sales offices, distributors and factory representatives

## CUSTOMER SUPPORT

Users of Microchip products can receive assistance through several channels:

- Distributor or Representative
- Local Sales Office
- Field Application Engineer (FAE)
- Technical Support
- Development Systems Information Line

Customers should contact their distributor, representative or field application engineer for support. Local sales offices are also available to help customers. A listing of sales offices and locations is included in the back of this document.

Technical support is available through the web site at: <http://support.microchip.com>

## DOCUMENT REVISION HISTORY

### Revision B (July 2006)

- Add disclaimer to Bill of Materials regarding RoHS-Compliant part numbers.

### Revision A (June 2004)

- Initial Release of this Document.

**NOTES:**





# TC1047A TEMPERATURE-TO-VOLTAGE CONVERTER PICtail™ DEMO BOARD USER'S GUIDE

---

---

## Chapter 1. Product Overview

---

---

### 1.1 INTRODUCTION

This chapter provides an overview of the TC1047A Temperature-to-Voltage Converter PICtail™ Demo Board, and covers the following topics:

- What is the TC1047A Temperature-to-Voltage Converter PICtail™ Demo Board?
- What the TC1047A Temperature-to-Voltage Converter PICtail™ Demo Board Kit includes

### 1.2 WHAT IS THE TC1047A TEMPERATURE-TO-VOLTAGE CONVERTER PICTAIL™ DEMO BOARD?

The TC1047A Temperature-to-Voltage Converter PICtail™ Demo Board demonstrates how to interface the TC1047A to a PICmicro® microcontroller using the PICKit™ 1 Flash Starter Kit as a platform. A PIC16F676 14-pin Flash-based 8-bit CMOS microcontroller device is included with the Demo Board that can be used with PICKit 1 Flash Starter Kit, along with firmware that provides the interface to the TC1047A and the voltage-to-temperature conversion routines.

The TC1047A Temperature-to-Voltage Converter PICtail™ Demo Board can also be used as a “stand-alone” module to quickly add thermal sensing capability to any existing application. This basic sensor functionality is implemented on a small Printed Circuit Board (PCB) and an interface via a standard 100 mil header.

### 1.3 WHAT THE TC1047A TEMPERATURE-TO-VOLTAGE CONVERTER PICTAIL™ DEMO BOARD KIT INCLUDES

This TC1047A Temperature-to-Voltage Converter PICtail™ Demo Board Kit includes:

- The TC1047A Temperature-to-Voltage Converter PICtail™ Demo Board
- TC1047A Temperature-to-Voltage Converter PICtail™ Demo Board User's Guide (DS51483)
- AN938, “Interfacing a TC1047A Analog Output Temperature Sensor to a PICmicro Microcontroller”, DS00938
- PIC16F676 14-pin Flash-based 8-bit CMOS Microcontroller
- PIC16F676 Firmware (TC1047A PICtail.HEX)

**NOTES:**

## Chapter 2. Installation and Operation

### 2.1 INTRODUCTION

The TC1047A Temperature-to-Voltage Converter PICtail™ Demo Board demonstrates how to interface the TC1047A device to a microcontroller for use by the system designer as an example of how to integrate an analog temperature sensor into their system.

### 2.2 FEATURES

The TC1047A Temperature-to-Voltage Converter PICtail™ Demo Board has the following features:

- Small PCB layout
- Standard 100 mil 14-pin header (P1) for easy interface to PICkit™ 1 Flash Starter Kit or custom application

### 2.3 GETTING STARTED

This section describes how to quickly set up the TC1047A Temperature-to-Voltage Converter PICtail™ Demo Board and PICkit 1 Flash Starter Kit. A block diagram of the setup is presented in Figure 2-1. Refer to Application Note 938, “Interfacing a TC1047A Analog Output Temperature Sensor to a PICmicro® Microcontroller” (DS00938), for detailed information on the TC1047A Temperature-to-Voltage Converter PICtail™ Demo Board and the TC1047A PICtail.HEX firmware.

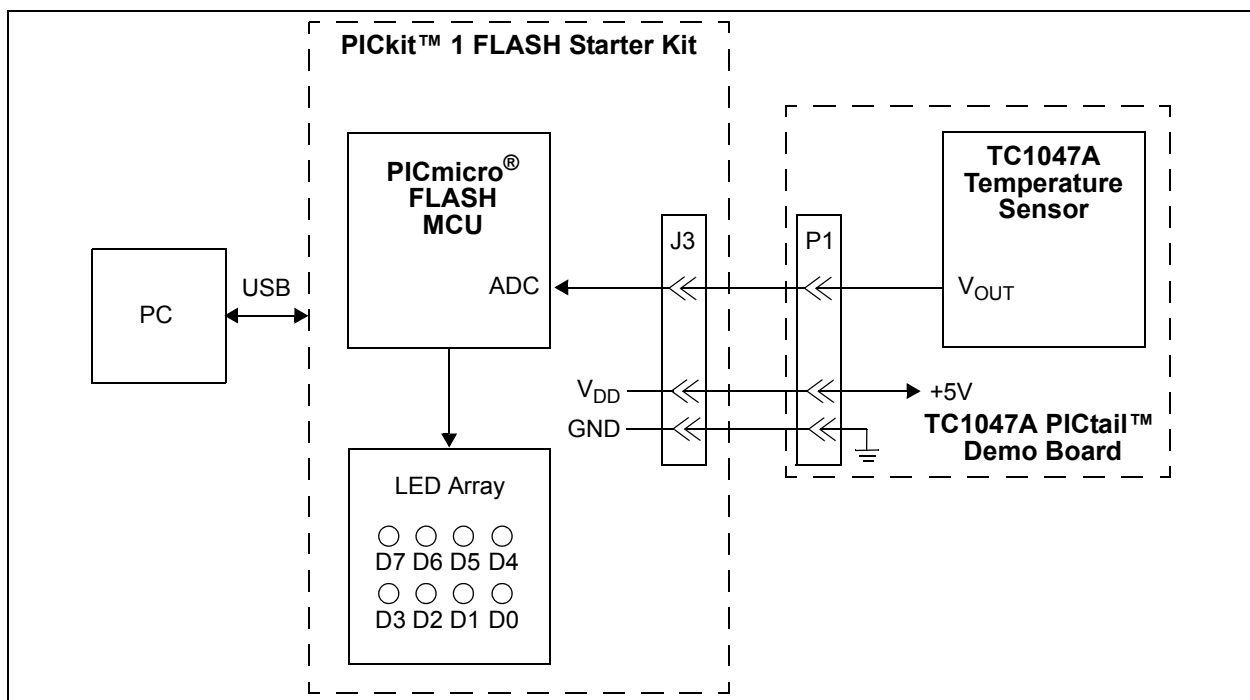

**FIGURE 2-1:** TC1047A Temperature-to-Voltage Converter PICtail™ Demo Board Block Diagram.

## 2.3.1 Hardware Setup

1. Connect the P1 header of the TC1047A Temperature-to-Voltage Converter PICtail™ Demo Board to the J3 connector on the PICKit 1 Flash Starter Kit board. Refer to Figure 2-2 for proper orientation of the TC1047A Temperature-to-Voltage Converter PICtail™ Demo Board and Figure 2-3 for the simplified board schematic.
2. Insert the PIC16F676 into the Evaluation socket of the PICKit 1 Flash Starter Kit board.
3. Connect the PICKit 1 Flash Starter Kit USB cable from the USB port of the PC to the USB port (J1) on the PICKit 1 Flash Starter Kit board. +5V power is supplied to the PICKit 1 Flash Starter Kit board via the USB cable. The green **POWER** LED and the red **BUSY** LED will turn on, indicating that power is being supplied to the board.

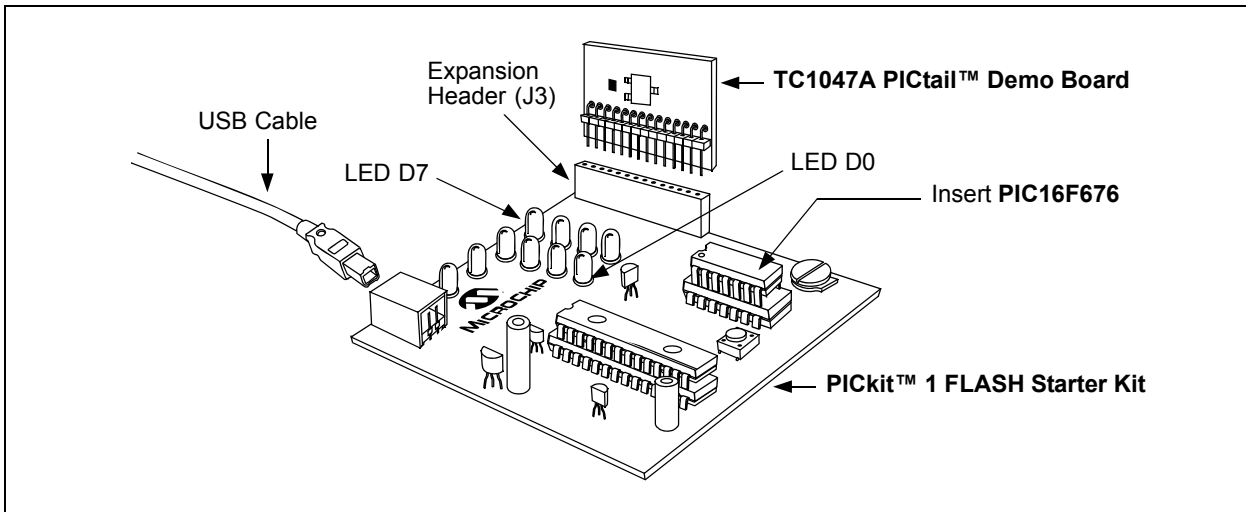

**FIGURE 2-2:** TC1047A PICtail™ Daughter Board and PICKit™ 1 Flash Starter Kit.

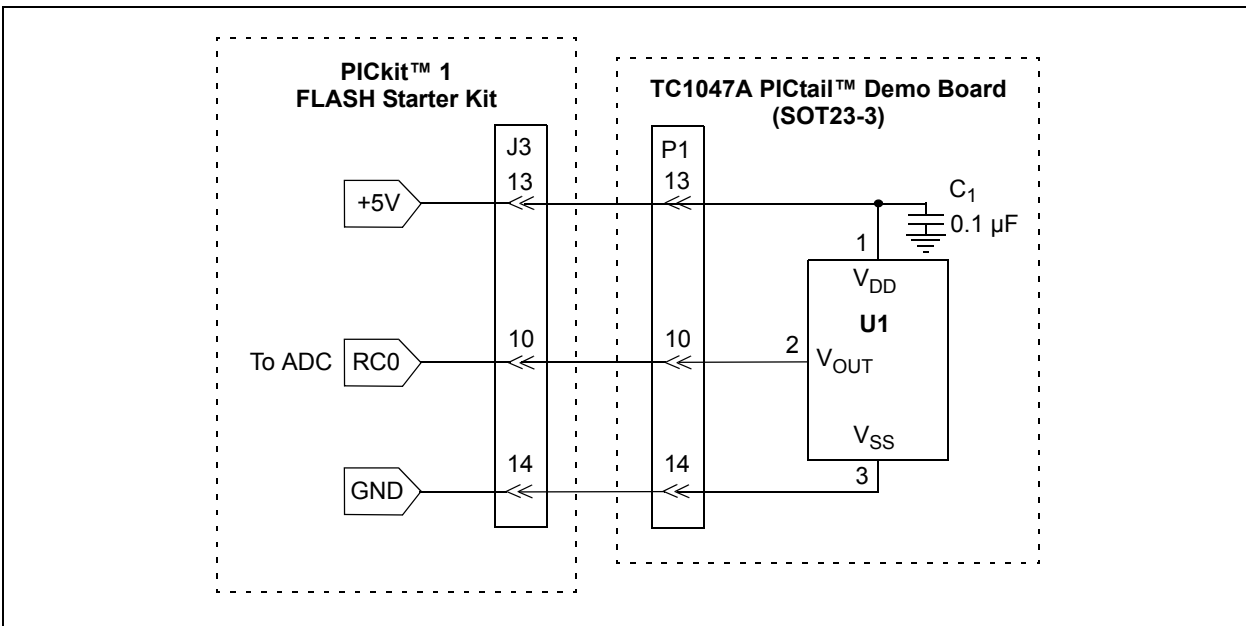

**FIGURE 2-3:** Simplified TC1047A PICtail™ Daughter Board Schematic.

## 2.3.2 Programming the PIC16F676

1. Download and install the PICkit 1 Flash Starter Kit software to your PC.
2. Copy the TC1047A PICtail.HEX file, supplied on the CD that came with this kit, to your PC.
3. When the PICkit 1 Flash Starter Kit is started, the main window will be displayed on the PC, as indicated in Figure 2-4.

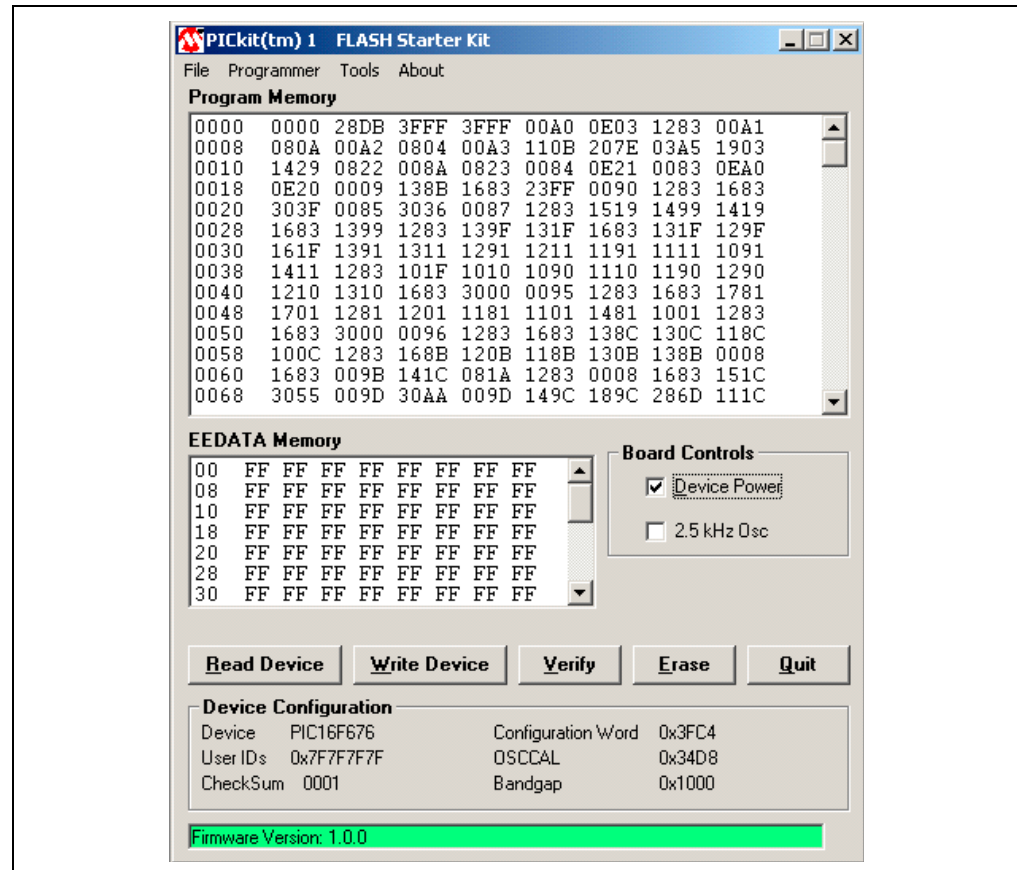

**FIGURE 2-4:** PICkit™ 1 Flash Starter Kit GUI Window on the PC.

4. Toggle device power to off by unchecking the **Device Power** box under **Board Controls** in the PICkit 1 Flash Starter Kit window (Figure 2-4). The **BUSY** LED on the PICkit 1 Flash Starter Kit board will turn off once the device power is turned off.
5. Click on the **Erase** button in the window to ensure that the PIC16F676 device has been erased.
6. From the **File** pull down menu, select **Import HEX**. A file window will appear. Select and open "**TC1047A PICtail.HEX**".
7. Click on the **Write Device** button in the PICkit 1 Flash Starter Kit window. The PIC16F676 device will be written to with the TC1047A PICtail.HEX firmware. When completed, the status bar at the bottom of the window will indicate **Write Successful**.
8. Toggle the device power on by checking the **Device Power** box under **Board Controls** in the PICkit 1 Flash Starter Kit window. The **BUSY** LED on the PICkit 1 Flash Starter Kit board will turn on when device power is turned on. Some of the red LEDs (D7-D0) will turn on as well.

At this point, the PIC16F676 device is reading the temperature data from the TC1047A and displaying the temperature on the eight red LEDs (D7-D0) on the PICKit 1 Flash Starter Kit board. The ten's digit of the temperature data is represented by bits D7-D4, with D7 being defined as the Most Significant bit (MSb). The one's digit is defined by bits D3-D0, with D3 serving as the MSb.

The temperature can be displayed in degrees Fahrenheit or Celsius. The board defaults to the temperature being displayed in Fahrenheit. To display the temperature in Celsius, depress the **SW1** push button switch on the PICKit 1 Flash Starter Kit board. The display will change back to Fahrenheit once the **SW1** push button switch is released.

Table 2-1 provides a list of the LED patterns that correspond to the BCD coding representation of the temperature measurement.

**TABLE 2-1: BCD CODE REPRESENTATION ON PICKit™ 1 FLASH STARTER KIT LEDES**

Binary	BCD Number	D7 D3	D6 D2	D5 D1	D4 D0
0000	0	OFF	OFF	OFF	OFF
0001	1	OFF	OFF	OFF	ON
0010	2	OFF	OFF	ON	OFF
0011	3	OFF	OFF	ON	ON
0100	4	OFF	ON	OFF	OFF
0101	5	OFF	ON	OFF	ON
0110	6	OFF	ON	ON	OFF
0111	7	OFF	ON	ON	ON
1000	8	ON	OFF	OFF	OFF
1001	9	ON	OFF	OFF	ON

For example, a temperature reading of 75°F will be displayed by turning on LEDs D6, D5, D4, D2 and D0 (LEDs D7, D3 and D1 will be turned off), as indicated in Figure 2-5.

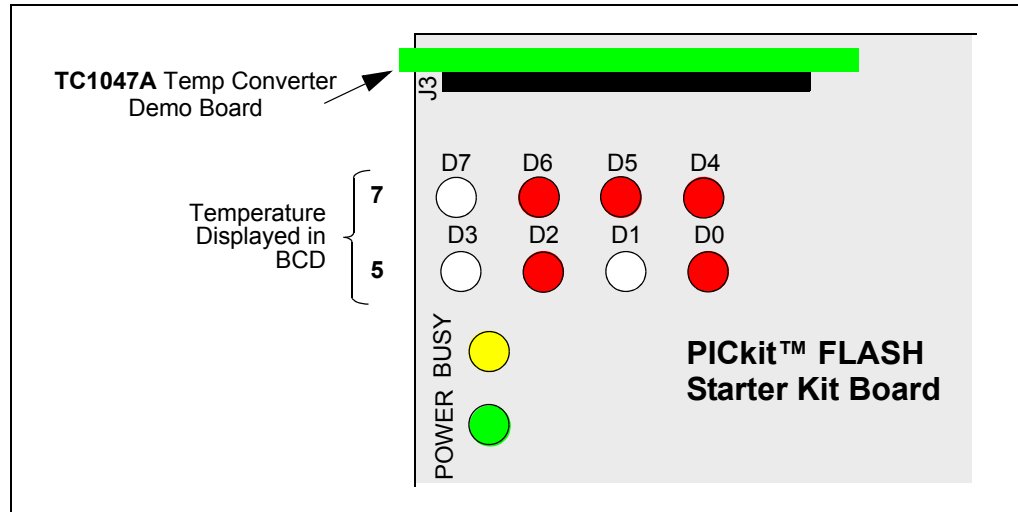

**FIGURE 2-5:** PICkit™ 1 Flash Starter Kit LED Display of 75°F.

The temperature display will change when the temperature of the TC1047A is varied. A simple example of this can be seen by pressing your finger on the TC1047A device (U1) on the TC1047A Temperature-to-Voltage Converter PICtail™ Demo Board. More dramatic changes can be seen by applying heat to the TC1047A with a hair dryer or hot air gun, or by cooling the device down.

Refer to the TC1047A Data Sheet, “Precision Temperature-to-Voltage Converter” (DS21498), for more information on the TC1047A, and Application Note 938, “Interfacing a TC1047A Analog Output Temperature Sensor to a PICmicro® Microcontroller”, for more information on the TC1047A Temperature-to-Voltage Converter PICtail™ Demo Board and the TC1047A PICtail.HEX firmware.

**NOTES:**





# TC1047A TEMPERATURE-TO-VOLTAGE CONVERTER PICtail™ DEMO BOARD USER'S GUIDE

---

---

## Appendix A. Schematic and Layouts

---

---

### A.1 INTRODUCTION

This appendix contains the following schematics and layouts for the TC1047A Temperature-to-Voltage Converter PICtail™ Demo Board User's Guide:

- Board Schematic
- Board - Top Layer
- Board - Silk Screen Layer
- Board - Bottom Layer

A.2 BOARD SCHEMATIC

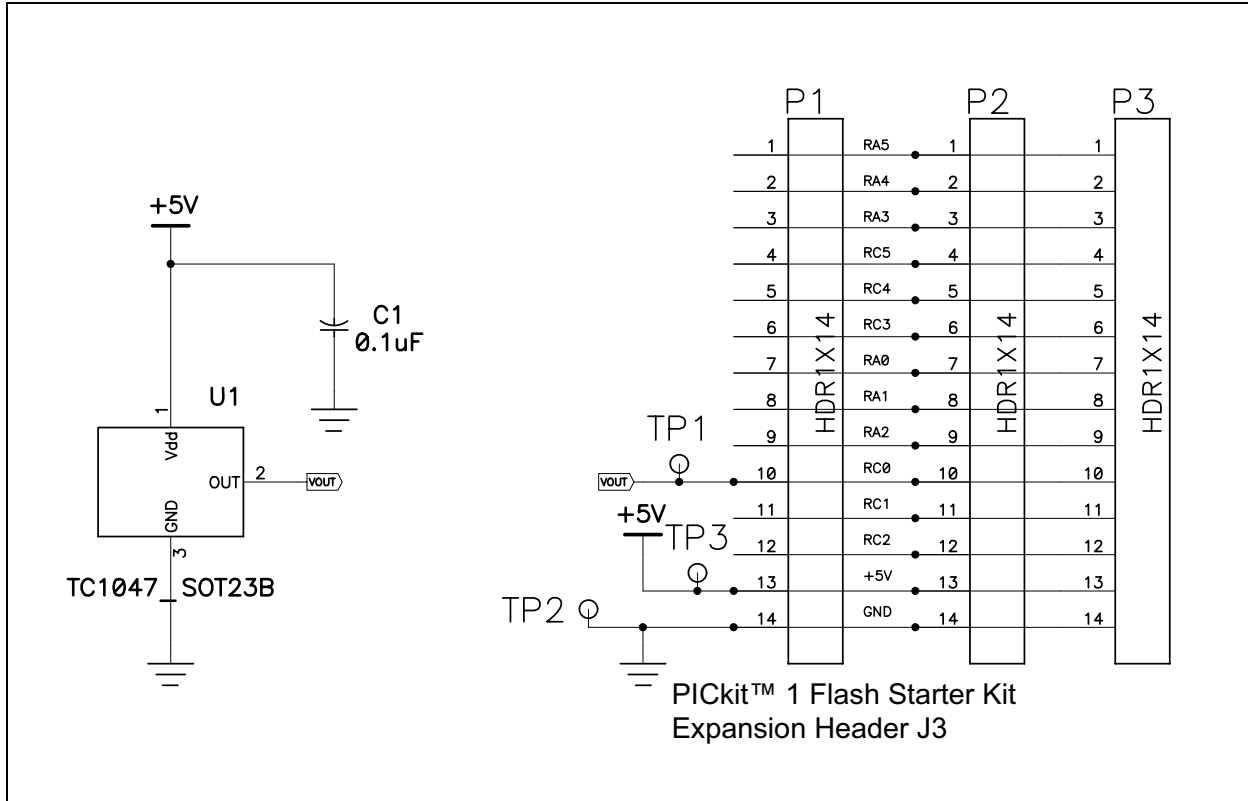

A.3 BOARD - TOP LAYER

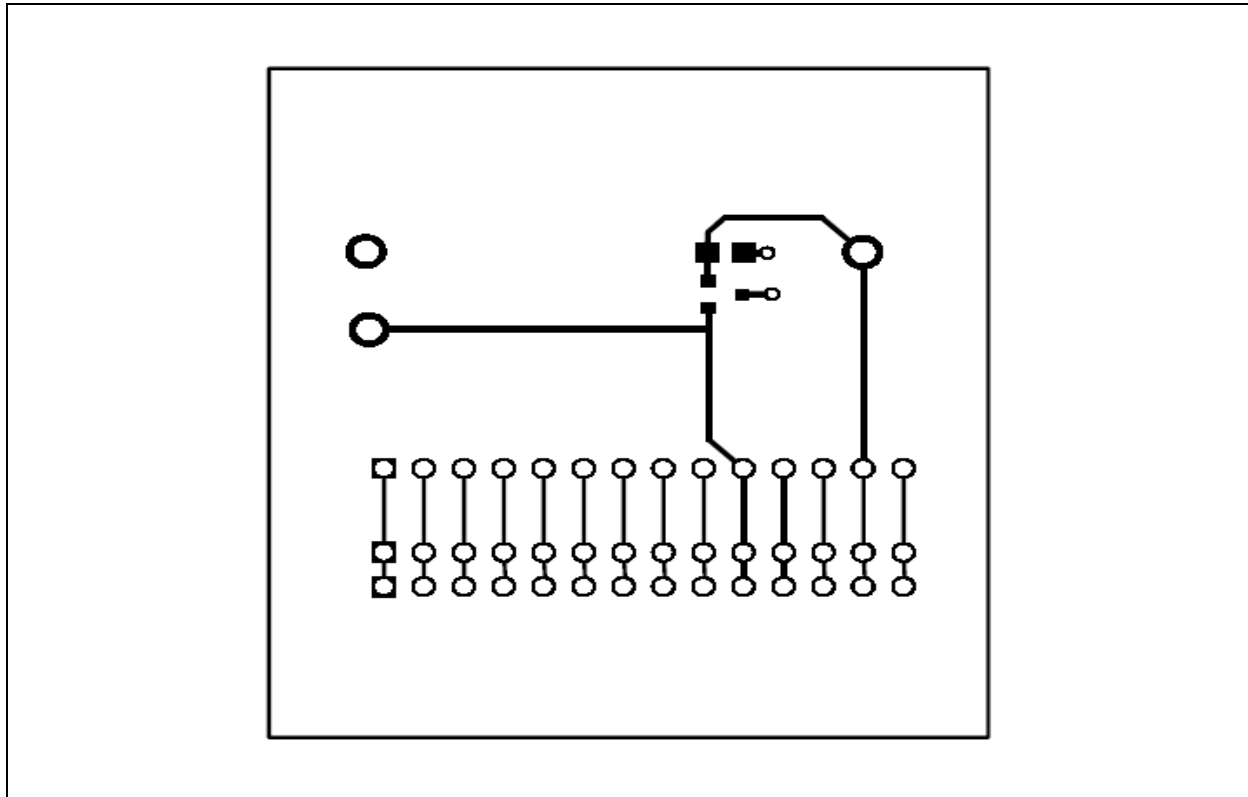

## A.4 BOARD - SILK SCREEN LAYER

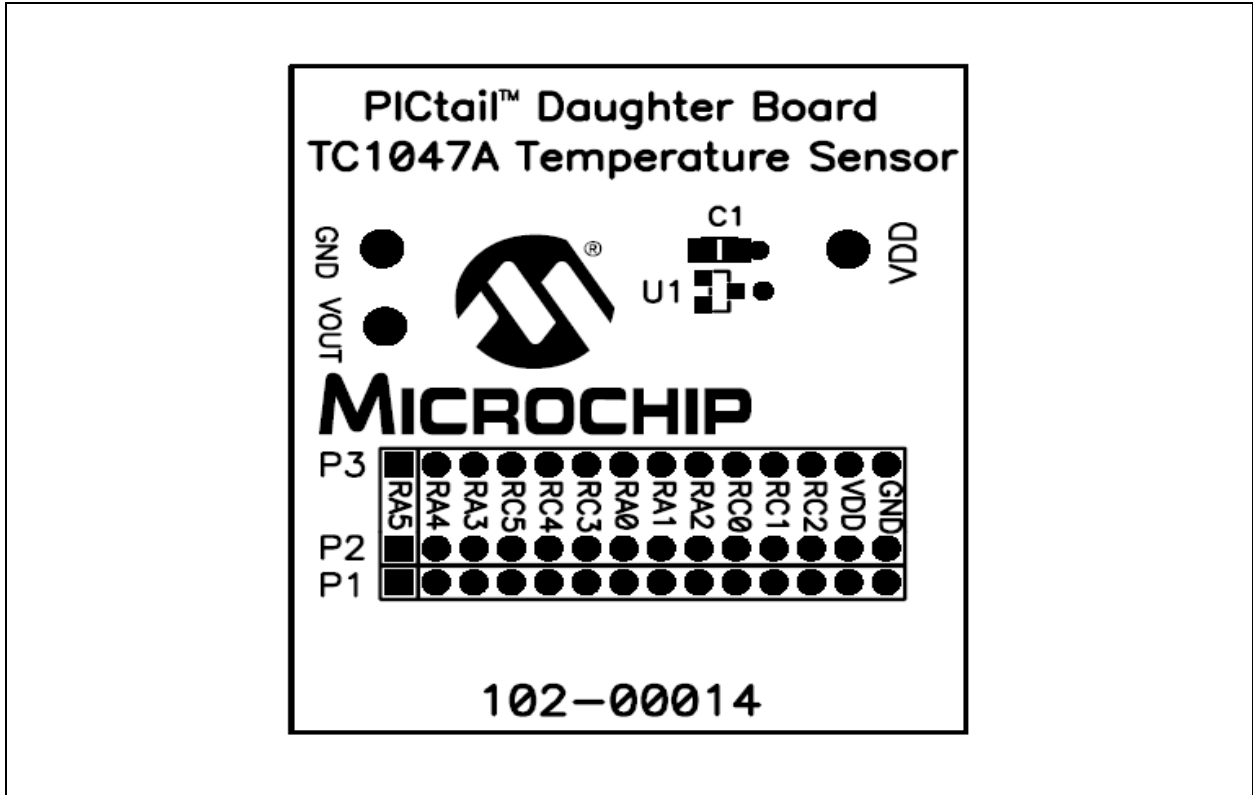

## A.5 BOARD - BOTTOM LAYER

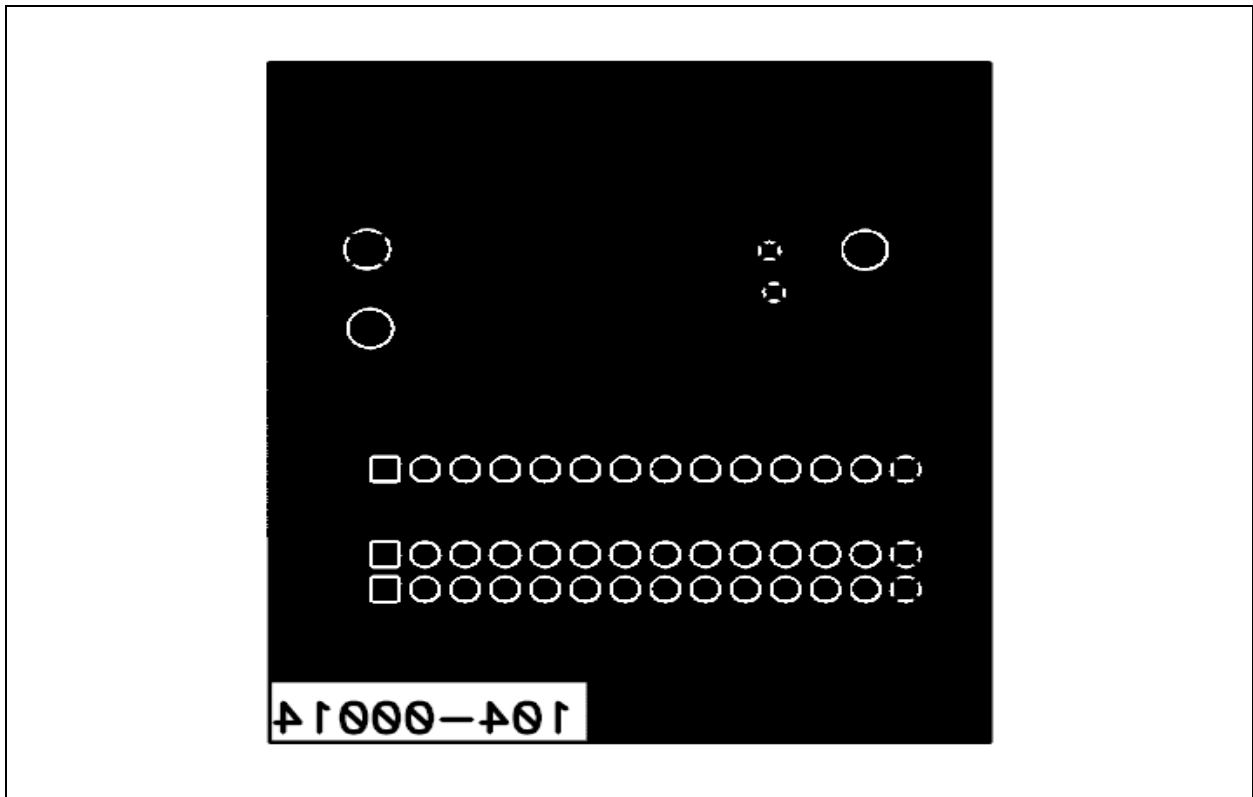

**NOTES:**



# TC1047A TEMPERATURE-TO-VOLTAGE CONVERTER PICtail™ DEMO BOARD USER'S GUIDE

## Appendix B. Bill Of Materials (BOM)

TABLE B-1: BILL OF MATERIALS

Qty	Designator	Description	Manufacturer	Part Number
1	C1	Cap., 0.1 $\mu$ F, 25V, Ceramic, X7R 0805	Panasonic®-ECG	ECJ-2VB1E104K
1	P1	Conn Hdr Brkway .100 40pos RT/A	AMP®/Tyco® Electronics	4-103765-0
1	U1	TC1047A Precision Temperature To Voltage Converter	Microchip Technology Inc.	TC1047AVNB

**Note 1:** The components listed in this Bill of Materials are representative of the PCB assembly. The released BOM used in manufacturing uses all RoHS-compliant components.



**MICROCHIP**

## WORLDWIDE SALES AND SERVICE

### AMERICAS

**Corporate Office**  
2355 West Chandler Blvd.  
Chandler, AZ 85224-6199  
Tel: 480-792-7200  
Fax: 480-792-7277  
Technical Support:  
<http://support.microchip.com>  
Web Address:  
[www.microchip.com](http://www.microchip.com)

**Asia Pacific Office**  
Suites 3707-14, 37th Floor  
Tower 6, The Gateway  
Harbour City, Kowloon  
Hong Kong  
Tel: 852-2401-1200  
Fax: 852-2401-3431

**Atlanta**  
Alpharetta, GA  
Tel: 770-640-0034  
Fax: 770-640-0307

**Boston**  
Westborough, MA  
Tel: 774-760-0087  
Fax: 774-760-0088

**Chicago**  
Itasca, IL  
Tel: 630-285-0071  
Fax: 630-285-0075

**Dallas**  
Addison, TX  
Tel: 972-818-7423  
Fax: 972-818-2924

**Detroit**  
Farmington Hills, MI  
Tel: 248-538-2250  
Fax: 248-538-2260

**Kokomo**  
Kokomo, IN  
Tel: 765-864-8360  
Fax: 765-864-8387

**Los Angeles**  
Mission Viejo, CA  
Tel: 949-462-9523  
Fax: 949-462-9608

**San Jose**  
Mountain View, CA  
Tel: 650-215-1444  
Fax: 650-961-0286

**Toronto**  
Mississauga, Ontario,  
Canada  
Tel: 905-673-0699  
Fax: 905-673-6509

### ASIA/PACIFIC

**Australia - Sydney**  
Tel: 61-2-9868-6733  
Fax: 61-2-9868-6755

**China - Beijing**  
Tel: 86-10-8528-2100  
Fax: 86-10-8528-2104

**China - Chengdu**  
Tel: 86-28-8676-6200  
Fax: 86-28-8676-6599

**China - Fuzhou**  
Tel: 86-591-8750-3506  
Fax: 86-591-8750-3521

**China - Hong Kong SAR**  
Tel: 852-2401-1200  
Fax: 852-2401-3431

**China - Qingdao**  
Tel: 86-532-8502-7355  
Fax: 86-532-8502-7205

**China - Shanghai**  
Tel: 86-21-5407-5533  
Fax: 86-21-5407-5066

**China - Shenyang**  
Tel: 86-24-2334-2829  
Fax: 86-24-2334-2393

**China - Shenzhen**  
Tel: 86-755-8203-2660  
Fax: 86-755-8203-1760

**China - Shunde**  
Tel: 86-757-2839-5507  
Fax: 86-757-2839-5571

**China - Wuhan**  
Tel: 86-27-5980-5300  
Fax: 86-27-5980-5118

**China - Xian**  
Tel: 86-29-8833-7250  
Fax: 86-29-8833-7256

### ASIA/PACIFIC

**India - Bangalore**  
Tel: 91-80-4182-8400  
Fax: 91-80-4182-8422

**India - New Delhi**  
Tel: 91-11-5160-8631  
Fax: 91-11-5160-8632

**India - Pune**  
Tel: 91-20-2566-1512  
Fax: 91-20-2566-1513

**Japan - Yokohama**  
Tel: 81-45-471-6166  
Fax: 81-45-471-6122

**Korea - Gumi**  
Tel: 82-54-473-4301  
Fax: 82-54-473-4302

**Korea - Seoul**  
Tel: 82-2-554-7200  
Fax: 82-2-558-5932 or  
82-2-558-5934

**Malaysia - Penang**  
Tel: 60-4-646-8870  
Fax: 60-4-646-5086

**Philippines - Manila**  
Tel: 63-2-634-9065  
Fax: 63-2-634-9069

**Singapore**  
Tel: 65-6334-8870  
Fax: 65-6334-8850

**Taiwan - Hsin Chu**  
Tel: 886-3-572-9526  
Fax: 886-3-572-6459

**Taiwan - Kaohsiung**  
Tel: 886-7-536-4818  
Fax: 886-7-536-4803

**Taiwan - Taipei**  
Tel: 886-2-2500-6610  
Fax: 886-2-2508-0102

**Thailand - Bangkok**  
Tel: 66-2-694-1351  
Fax: 66-2-694-1350

### EUROPE

**Austria - Wels**  
Tel: 43-7242-2244-3910  
Fax: 43-7242-2244-393

**Denmark - Copenhagen**  
Tel: 45-4450-2828  
Fax: 45-4485-2829

**France - Paris**  
Tel: 33-1-69-53-63-20  
Fax: 33-1-69-30-90-79

**Germany - Munich**  
Tel: 49-89-627-144-0  
Fax: 49-89-627-144-44

**Italy - Milan**  
Tel: 39-0331-742611  
Fax: 39-0331-466781

**Netherlands - Drunen**  
Tel: 31-416-690399  
Fax: 31-416-690340

**Spain - Madrid**  
Tel: 34-91-708-08-90  
Fax: 34-91-708-08-91

**UK - Wokingham**  
Tel: 44-118-921-5869  
Fax: 44-118-921-5820

06/08/06