

## Quad channel high-side driver

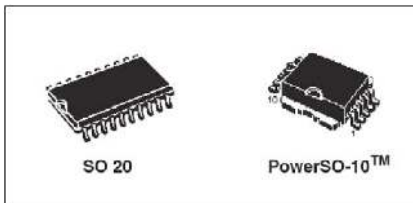

### Features

- $V_{CC(AMR)} = 41\text{ V}$
- $R_{DS(on)} \leq 0.270\ \Omega$  @  $T_J = 25\text{ }^\circ\text{C}$  (per channel)
- Fast demagnetization of inductive loads,  $V_{DEMAG(TYP)} = V_{CC} - 52\text{ V}$
- Very low standby current
- CMOS compatible I/Os
- Per channel process side op. current  $I_{OUT}$  up to 0.35A
- Undervoltage and overvoltage shutdown
- Short circuit protection on output channels
- Per-channel thermal shutdown protection and diagnostic
- Protection against loss of ground

### Application

- Industrial PC peripheral input/output
- Numerical control machines
- Drivers for all type of loads (resistive, capacitive, inductive)

### Description

The VNQ860-E and VNQ860SP-E are monolithic devices realized in STMicroelectronics VIPower M0-3 technology, intended to drive any kind of load with one side connected to ground. Active current limitation combined with thermal shutdown and automatic restart protect the device against overload. The device automatically turns OFF in case of ground pin disconnection. This device is especially suitable for IEC 61131 compliant industrial applications.

#### Product status link

[VNQ860-E](#)

[VNQ860SP-E](#)

#### Product label



# 1 Block diagram

Figure 1. Block diagram

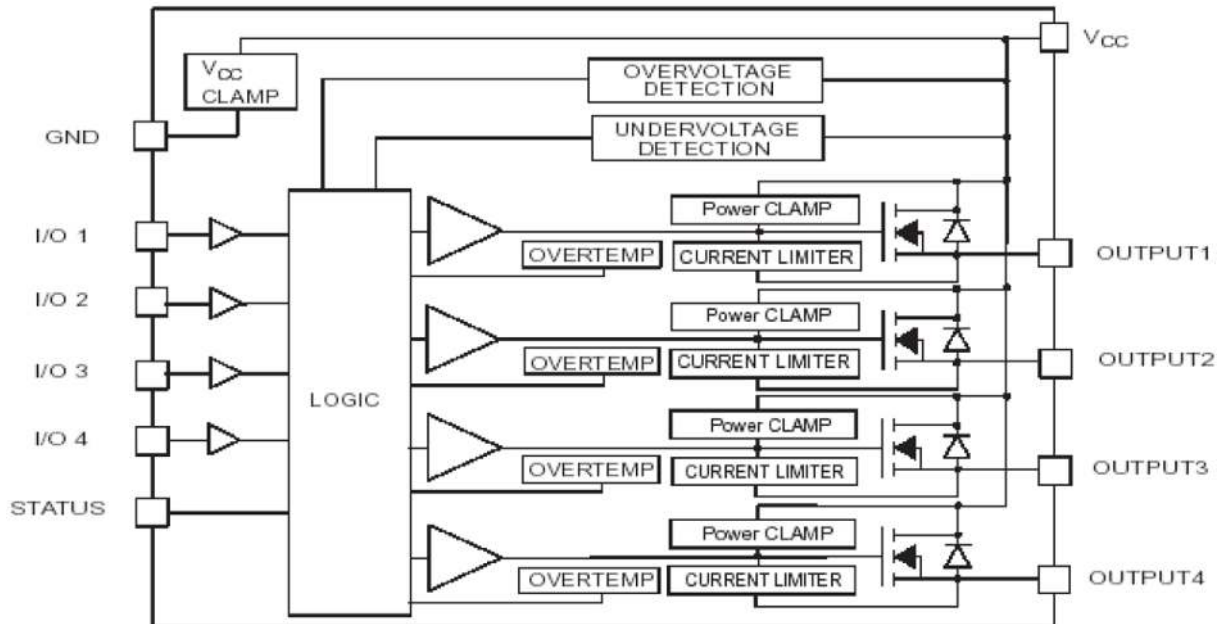

## 2 Absolute maximum ratings

**Table 1. Absolute maximum ratings**

Symbol	Parameter	Value	Unit
$V_{CC}$	DC supply voltage	41	V
$-V_{CC}$	Reverse DC supply voltage	-0.3	V
$-I_{GND}$	Reverse DC ground pin	-200	mA
$I_{OUT}$	DC output current	Internally limited	A
$-I_{OUT}$	Reverse DC output current	-2	A
$I_{IN}$	DC input current	$\pm 10$	mA
$V_{IN}$	Input voltage range	-3/+ $V_{CC}$	V
$V_{STAT}$	DC status pin voltage	+ $V_{CC}$	V
$V_{ESD}$	Electrostatic discharge ( $R = 1.5\text{ k}\Omega$ ; $C = 100\text{ pF}$ )	2000	V
$P_{tot}$	Power dissipation at $T_c \leq 25\text{ }^\circ\text{C}$	Internally limited <sup>(1)</sup>	W
$T_J$	Junction operating temperature	Internally limited <sup>(1)</sup>	$^\circ\text{C}$
$T_c$	Case operating temperature	-40 to 150	$^\circ\text{C}$
$T_{stg}$	Storage temperature	-55 to 150	$^\circ\text{C}$

1. Protection functions are intended to avoid IC damage in fault conditions and are not intended for continuous operation. Continuous and repetitive operation of protection functions may reduce the IC lifetime.

### 3 Thermal data

Table 2. Thermal data

Symbol	Parameter	Max. Values		Unit
		SO20	PowerSO-10	
Rth(j-p)	Thermal resistance junction-pins	8	-	°C/W
Rth(j-a)	Thermal resistance junction-ambient	58	52 <sup>(1)</sup> ; 37 <sup>(2)</sup>	
Rth(j-c)	Thermal resistance junction-case	-	1.4	

1. When mounted on FR4 printed circuit board with 0.5 cm<sup>2</sup> of copper area (at least 35µm thick) connected to all VCC pins.
2. When mounted on FR4 printed circuit board with 6 cm<sup>2</sup> of copper area (at least 35µm thick) connected to all VCC pins.

## 4 Pin connection

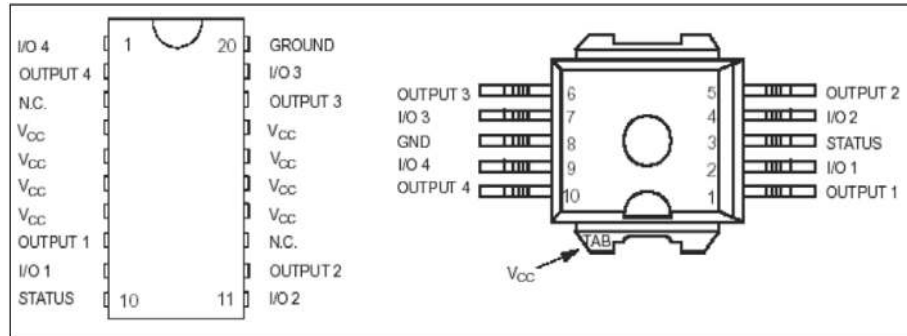
**Figure 2. Configuration diagram (top view)**

**Table 3. Pin connection**

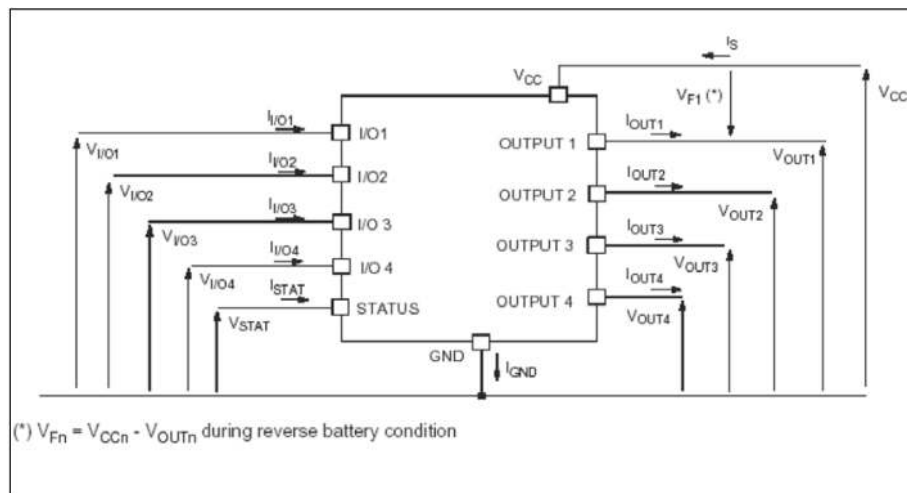
Connection/Pin	Status	N.C.	Output	Input
Floating	X	X	X	X
To ground		X		Through 10 kΩ resistor

**Figure 3. Current and Voltage Conventions**

## 5 Electrical characteristics

8 V < V<sub>CC</sub> < 36 V; -40 °C < T<sub>J</sub> < 150 °C; unless otherwise specified.

**Table 4. Power section**

Symbol	Parameter	Test conditions	Min.	Typ.	Max.	Unit
V <sub>CC</sub>	Operating supply-voltage		5.5		36	V
V <sub>USD</sub>	Undervoltage shutdown		3	4	5.5	V
V <sub>OV</sub>	Overvoltage shutdown		36	42	48	V
R <sub>ON</sub>	On state resistance (per channel)	I <sub>OUT</sub> = 0.25 A; T <sub>J</sub> = 25 °C			270	mΩ
		I <sub>OUT</sub> = 0.25 A			540	
I <sub>S</sub>	Supply current	OFF state; V <sub>CC</sub> = 24 V; T <sub>C</sub> = 25°C		70	120	μA
		ON state (all channels ON)		5	10	mA
I <sub>LGND</sub>	Output current at GND disconnection	V <sub>CC</sub> = V <sub>STAT</sub> = V <sub>IN</sub> = V <sub>GND</sub> = 24V; V <sub>OUT</sub> = 0 V			1	mA
I <sub>L(OFF)</sub>	OFF state output current	V <sub>IN</sub> = V <sub>OUT</sub> = 0 V	0		10	μA
I <sub>OUTleak</sub>	OFF state output leakage current	V <sub>IN</sub> = V <sub>GND</sub> = 0 V; V <sub>CC</sub> = V <sub>OUT</sub> = 24 V; T <sub>A</sub> = 25 °C			240	μA
		V <sub>IN</sub> = V <sub>GND</sub> = 0 V; V <sub>CC</sub> = 24 V; V <sub>OUT</sub> = 10 V; T <sub>A</sub> = 25 °C			100	

**Table 5. Switching (V<sub>CC</sub> = 24 V, R<sub>LOAD</sub> = 96 Ω)**

Symbol	Parameter	Test conditions	Min.	Typ.	Max.	Unit
t <sub>(ON)</sub>	Turn-on delay time of output current	From V <sub>IN</sub> rising edge to V <sub>OUT</sub> = 2.4 V		10		μs
t <sub>(OFF)</sub>	Turn-off delay time of output current	From V <sub>IN</sub> falling edge to V <sub>OUT</sub> = 21.6 V		40		μs
(dV <sub>OUT</sub> /dt) <sub>ON</sub>	Turn-on voltage slope	From V <sub>OUT</sub> = 2.4 V to 19.2 V		0.75		V/μs
(dV <sub>OUT</sub> /dt) <sub>OFF</sub>	Turn-off voltage slope	From V <sub>OUT</sub> = 21.6 V to 2.4 V		0.25		V/μs

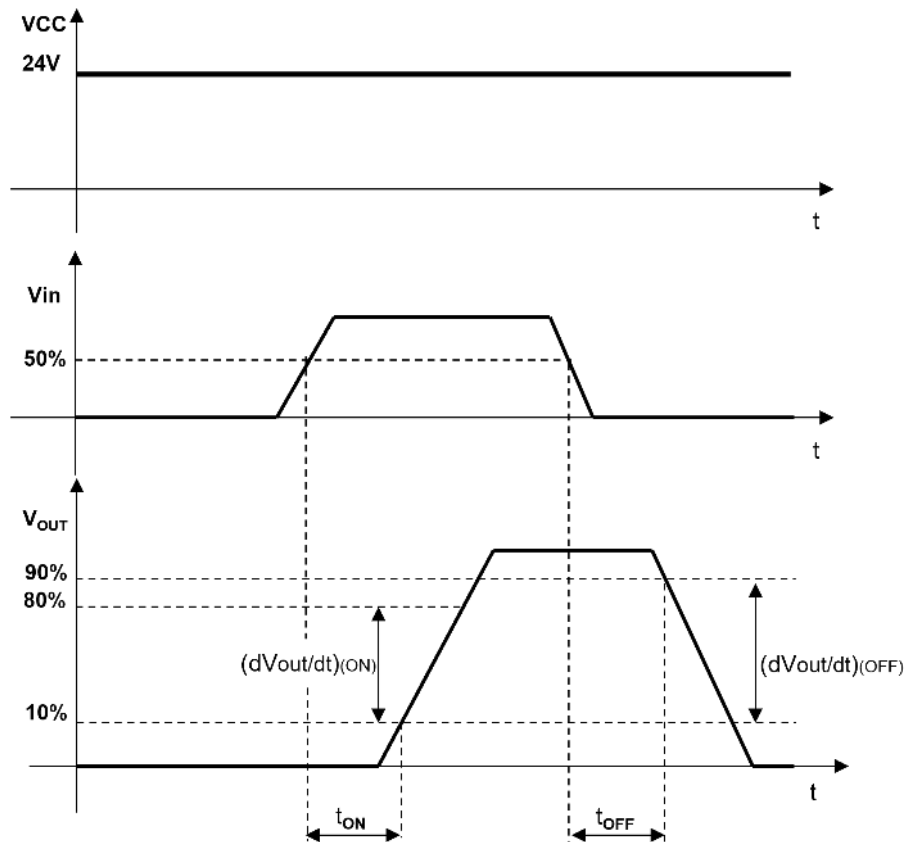
**Figure 4. Switching characteristics**

**Table 6. Protections (per channels)**

Symbol	Parameter	Test conditions	Min.	Typ.	Max.	Unit
$I_{LIM}$	Current limitation		0.35	0.7	1.1	A
$T_{TSD}$	Thermal shutdown temperature		150	175	200	°C
$T_R$	Reset temperature		135			°C
$T_{(hyst)}$	Thermal hysteresis		7	15		°C
$V_{demag}$	Turn-off output clamp voltage	$I_{OUT} = 0.25 \text{ A}$ , $V_{CC} = 24 \text{ V}$	$V_{CC}-59$	$V_{CC}-52$	$V_{CC}-47$	V

**Table 7. Logic Input (per channel)**

Symbol	Parameter	Test conditions	Min.	Typ.	Max.	Unit
$V_{IL}$	Low level input voltage				1.25	V
$I_{IL}$	Low level input current	$V_{IN} = 1.25 \text{ V}$	1			$\mu\text{A}$
$V_{IH}$	High level input voltage		3.25			V
$I_{IH}$	High level input current	$V_{IN} = 3.25 \text{ V}$			10	$\mu\text{A}$
$V_{I(HYST)}$	Input hysteresis voltage		0.5			V
$I_{IN}$	Input current	$V_{IN} = V_{CC} = 36 \text{ V}$			200	$\mu\text{A}$
$V_{OL}$	I/O output voltage	$I_{IN} = 5 \text{ mA}$ (fault condition)			1	V

**Table 8. Status pin**

Symbol	Parameter	Test conditions	Min.	Typ.	Max.	Unit
$V_{STAT}$	Status low output voltage	$I_{STAT} = 5 \text{ mA}$ (fault condition)			1	V
$I_{LSTAT}$	Status leakage current	Normal operation; $V_{STAT} = V_{CC} = 36 \text{ V}$			20	$\mu\text{A}$
$C_{STAT}$	Status pin input capacitance	Normal operation; $V_{STAT} = 5 \text{ V}$			100	pF

**Table 9.  $V_{CC}$  - output diode**

Symbol	Parameter	Test conditions	Min.	Typ.	Max.	Unit
$V_F$	Forward on voltage	$-I_{OUT} = 0.3 \text{ A}$ ; $T_J = 150 \text{ }^\circ\text{C}$			1	V



## 6 Truth table

**Table 10. Truth table**

Conditions	MCOUT <sub>n</sub>	(I/O) <sub>n</sub>	OUTPUT <sub>n</sub>	STATUS
Normal operation	L	L	L	H
	H	H	H	H
Current limitation	L	L	L	H
	H	H	X	H
Overtemperature	L	L	L	L
	H	Driven low	L	L
Undervoltage	L	L	L	X
	H	H	L	X
Overvoltage	L	L	L	H
	H	H	L	H

Note: X = don't care

## 7 Typical application schematic

Figure 5. Typical application schematic

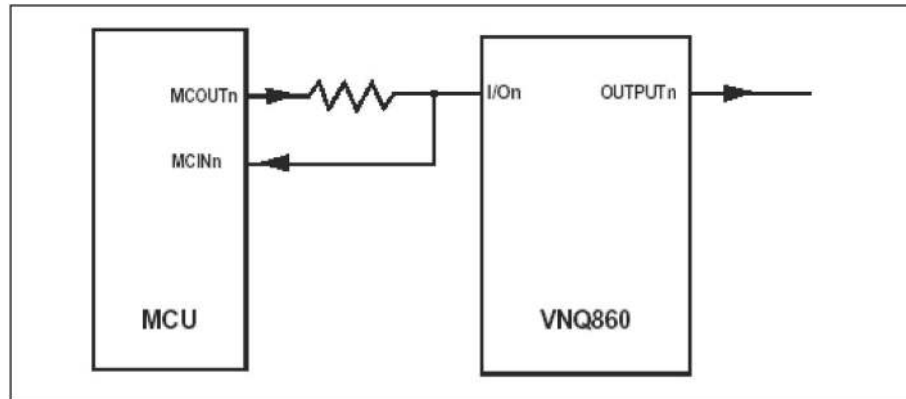

## 8 Waveforms

Figure 6. Waveforms

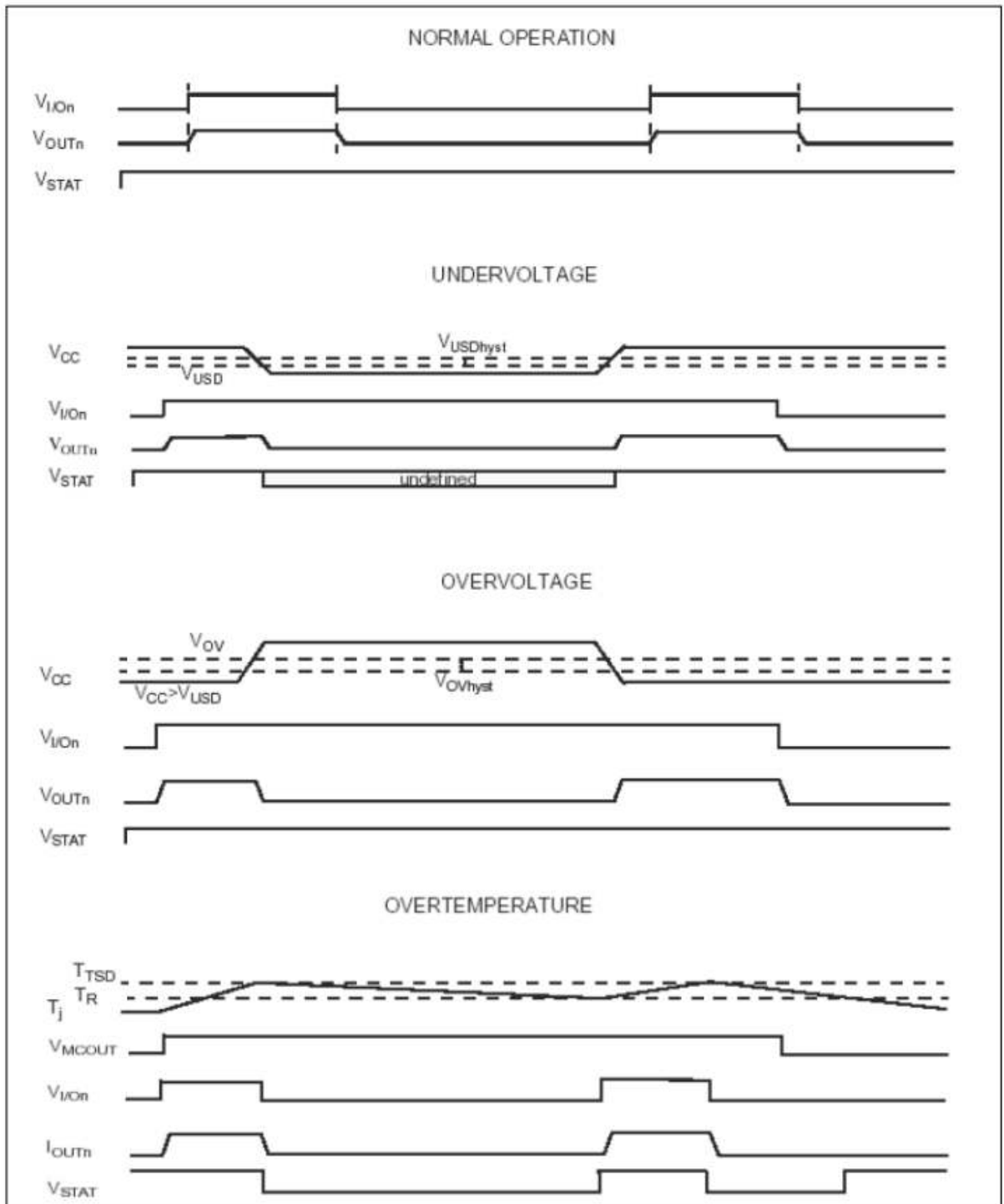

## 9 PowerSO-10™ thermal data

Figure 7. PowerSO-10™ PC board

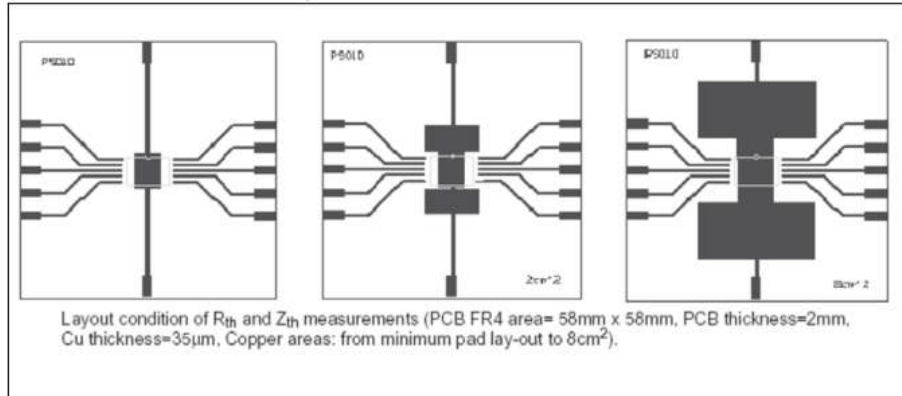
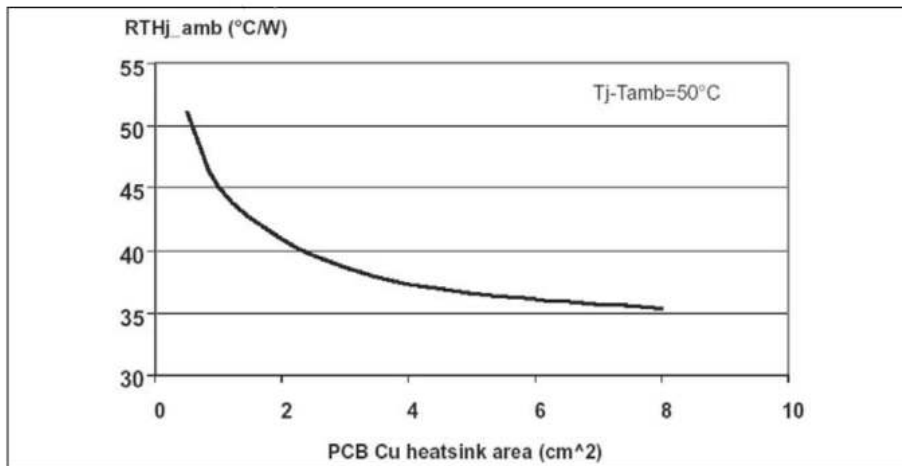

Figure 8.  $R_{th(JA)}$  vs PBC copper area in open box free air condition



## 10 Reverse polarity protection

A solution to protect the IC against a reverse polarity condition is proposed in [Figure 9. Reverse polarity protection](#).

This schematic is valid with any type of load connected to the outputs of the IC.

The  $R_{GND}$  resistor value can be selected according to the following conditions:

### Equation 1

$$R_{GND} \leq 600 \text{ mV} / (-I_{S(ON)MAX})$$

### Equation 2

$$R_{GND} \geq (-V_{CC}) / (-I_{GND})$$

where  $-I_{GND}$  is the DC reverse ground pin current and can be found in [Table 1. Absolute maximum ratings](#).

The power dissipated by  $R_{GND}$  during reverse polarity is:

$$P_D = (-V_{CC})^2 / R_{GND}$$

This resistor can be shared by different ICs. In such case,  $I_S$  value, indicated in [Equation 1](#), is the sum of the maximum ON-state currents of the different devices.

Please note that, if the microprocessor ground and the device ground are separated then the voltage drop across the  $R_{GND}$  (given by  $I_S$  in ON state max. \*  $R_{GND}$ ) produces a difference between the generated input level and the IC input signal level. This voltage drop varies depending on how many devices are ON in the case of several high-side switches sharing the same  $R_{GND}$ .

**Figure 9. Reverse polarity protection**

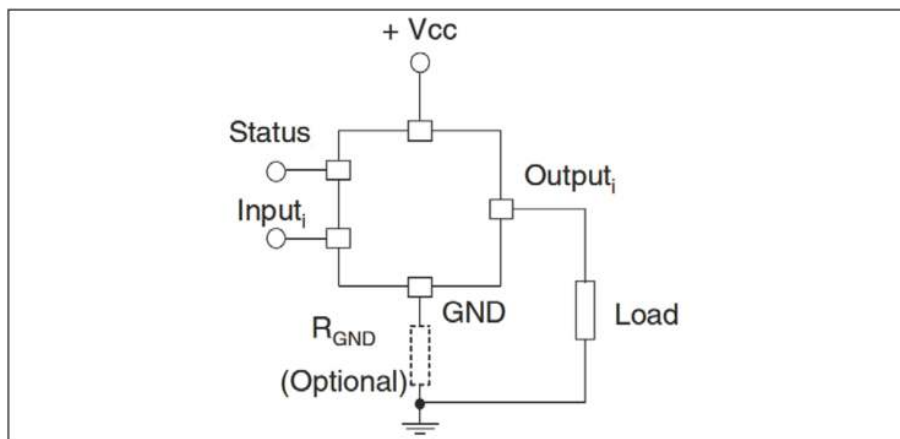

## 11 Package mechanical data

In order to meet environmental requirements, ST offers these devices in different grades of ECOPACK® packages, depending on their level of environmental compliance. ECOPACK® specifications, grade definitions and product status are available at: [www.st.com](http://www.st.com) ECOPACK® is an ST trademark.

**Table 11. PowerSO-10™ mechanical data**

Dim.	mm			inch		
	Min.	Typ.	Max.	Min.	Typ.	Max.
A	3.35		3.65	0.132		0.144
A1	0.00		0.10	0.000		0.004
B	0.40		0.60	0.016		0.024
c	0.35		0.55	0.013		0.022
D	9.40		9.60	0.370		0.378
D1	7.40		7.60	0.291		0.300
E	9.30		9.50	0.366		0.374
E1	7.20		7.40	0.283		0.291
E2	7.20		7.60	0.283		0.300
E3	6.10		6.35	0.240		0.250
E4	5.90		6.10	0.232		0.240
e		1.27			0.050	
F	1.25		1.35	0.049		0.053
H	13.80		14.40	0.543		0.567
h		0.50			0.002	
L	1.20		1.80	0.047		0.071
q		1.70			0.067	
a	0°		8°			

Figure 10. PowerSO-10™ package dimensions

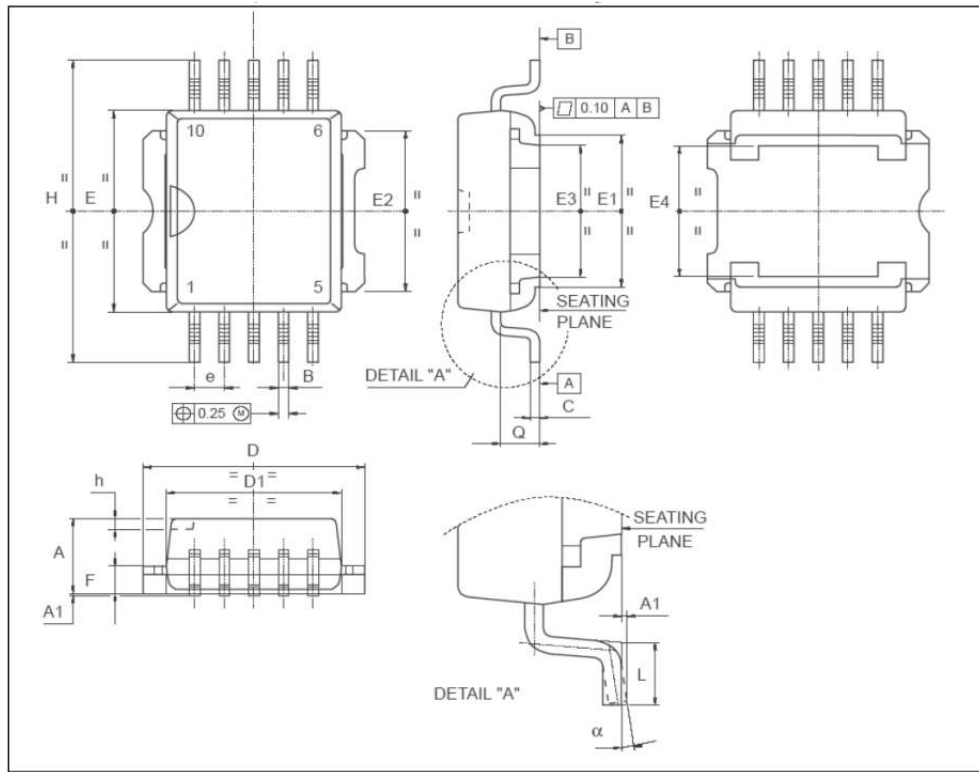

Figure 11. PowerSO-10™ suggested pad and tube shipment (no suffix)

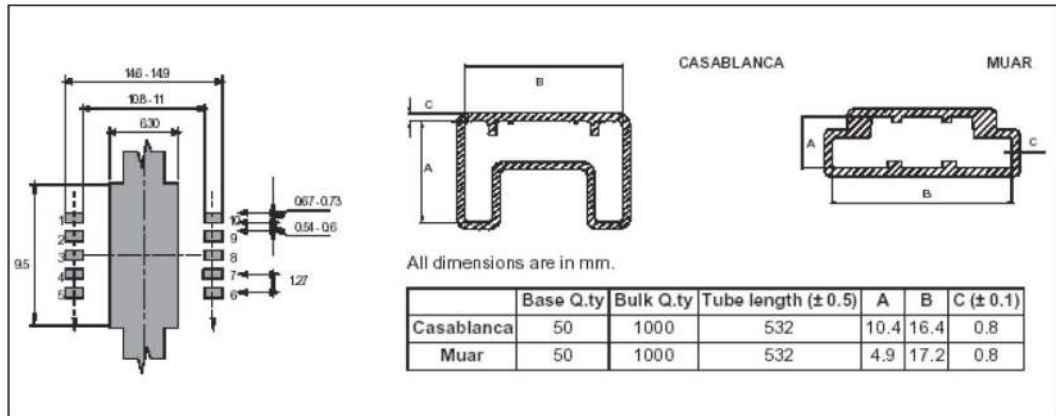

Figure 12. PowerSO-10™ tape and reel shipment (suffix “TR”)

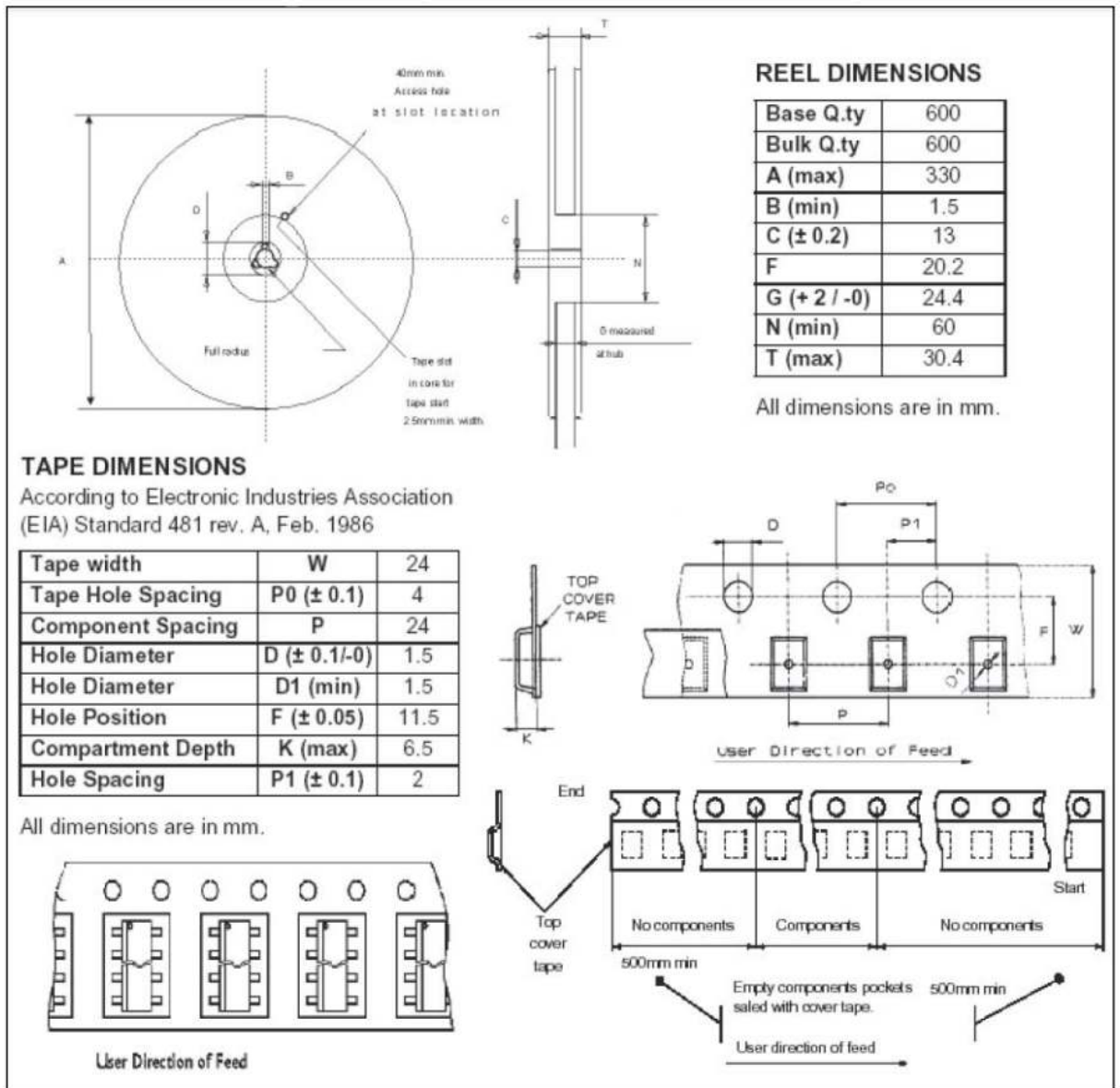



Figure 13. SO20 mechanical data and package dimensions

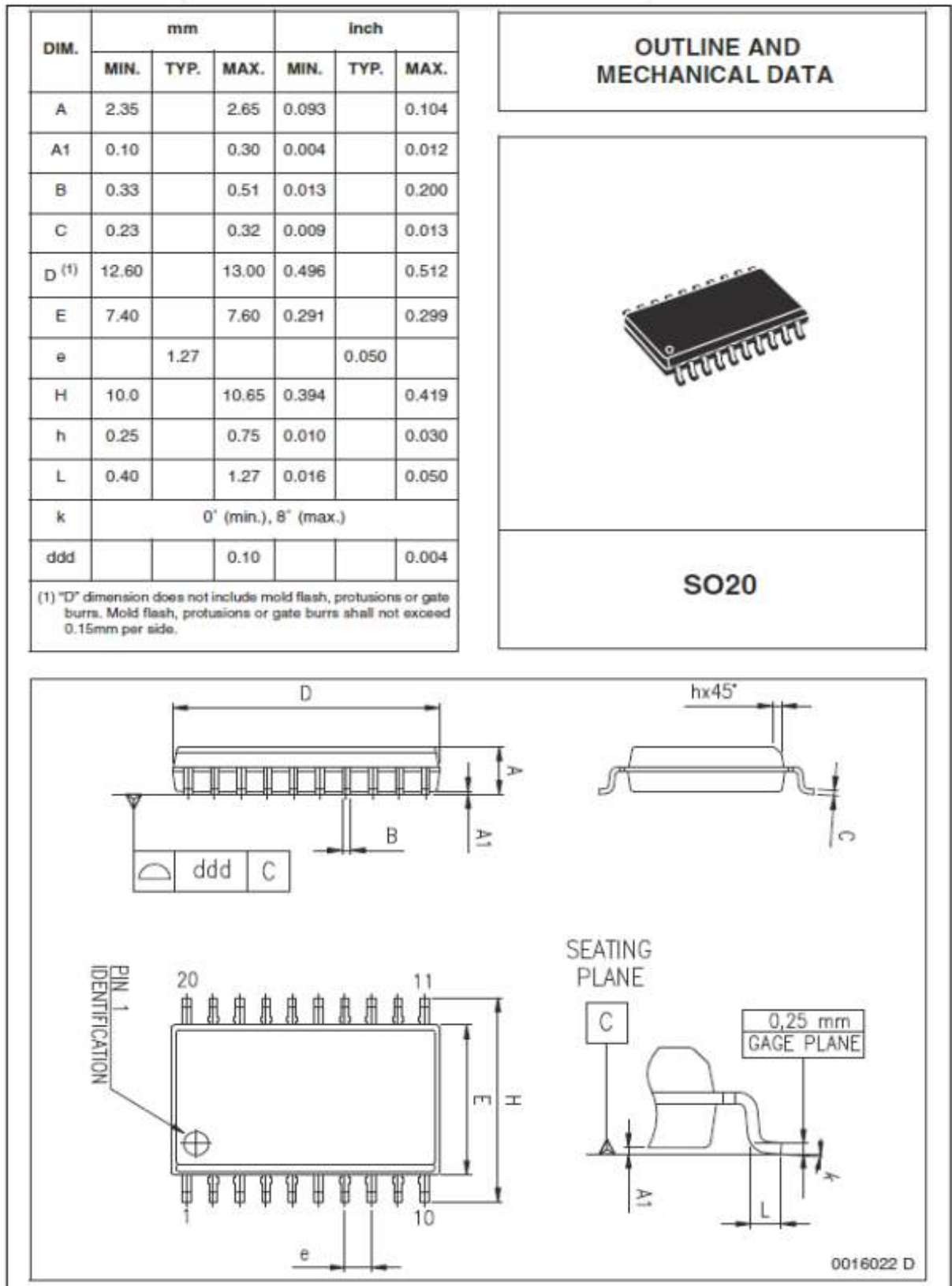

Figure 14. SO20 tube shipment (no suffix)

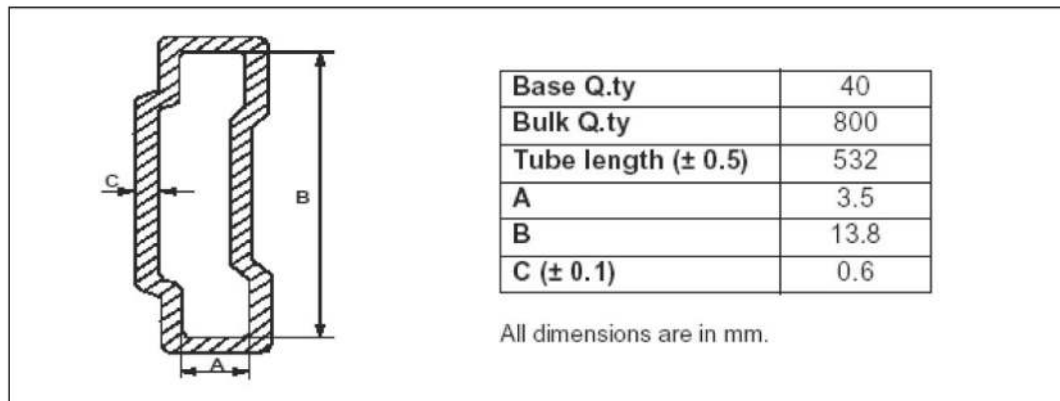
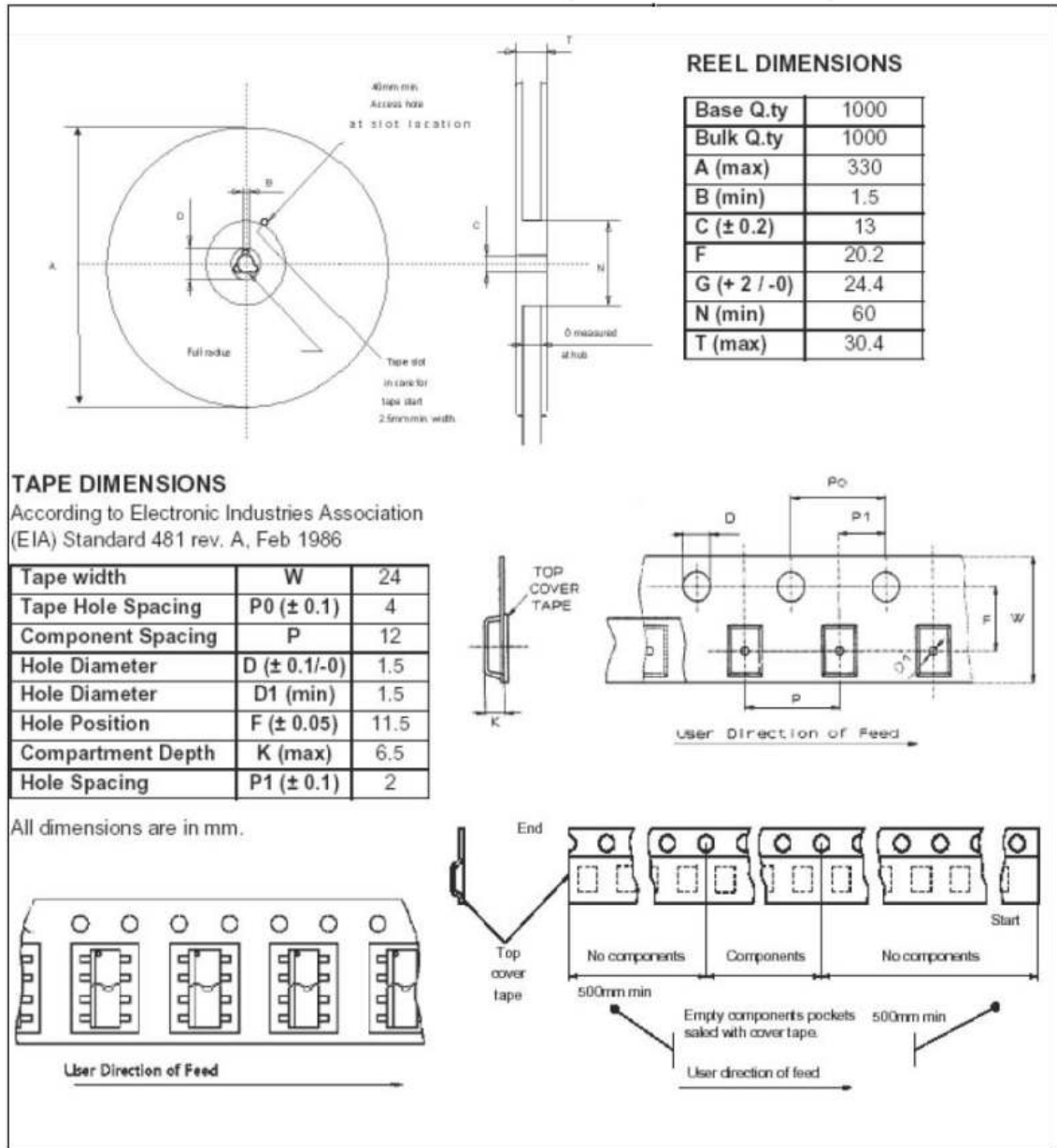

Figure 15. SO20 Tape and reel shipment (suffix "13TR")



## 12 Ordering information

**Table 12. Ordering information**

Order codes	Package	Packaging
VNQ860-E	SO20	Tube
VNQ860SP-E	PowerSO-10™	
VNQ860TR-E	SO20	Tape and reel
VNQ860SPTR-E	PowerSO-10™	

## Revision history

**Table 13. Document revision history**

Date	Version	Changes
14-Jul-2005	1	Updates, new template
7-Nov-2005	2	Few updates
7-Jul-2008	3	Added Section 8 on page 11
28-Apr-2009	4	Updated Figure 13 on page 15
05-May-2010	5	Updated coverpage
31-Aug-2010	6	Updated Table 10 on page 7
15-Mar-2013	7	Updated Table 1 and Table 12. Minor text changes
15-Jan-2020	8	Change to Table 8 value.
12-Oct-2021	9	New template; updated Table 1; Table 4: corrected $I_{LGND}$ parameter and test conditions definitions; Table 5: corrected typo in $t_{(OFF)}$ test conditions; changed Figure 4. Switching characteristics and moved in Section 5 Electrical characteristics; minor text changes.

## Contents

<b>1</b>	<b>Block diagram</b> .....	<b>2</b>
<b>2</b>	<b>Absolute maximum ratings</b> .....	<b>3</b>
<b>3</b>	<b>Thermal data</b> .....	<b>4</b>
<b>4</b>	<b>Pin connection</b> .....	<b>5</b>
<b>5</b>	<b>Electrical characteristics</b> .....	<b>6</b>
<b>6</b>	<b>Truth table</b> .....	<b>9</b>
<b>7</b>	<b>Typical application schematic</b> .....	<b>10</b>
<b>8</b>	<b>Waveforms</b> .....	<b>11</b>
<b>9</b>	<b>PowerSO-10™ thermal data</b> .....	<b>12</b>
<b>10</b>	<b>Reverse polarity protection</b> .....	<b>13</b>
<b>11</b>	<b>Package mechanical data</b> .....	<b>14</b>
<b>12</b>	<b>Ordering information</b> .....	<b>20</b>
	<b>Revision history</b> .....	<b>21</b>

## List of figures

<b>Figure 1.</b>	Block diagram . . . . .	2
<b>Figure 2.</b>	Configuration diagram (top view). . . . .	5
<b>Figure 3.</b>	Current and Voltage Conventions . . . . .	5
<b>Figure 4.</b>	Switching characteristics . . . . .	7
<b>Figure 5.</b>	Typical application schematic . . . . .	10
<b>Figure 6.</b>	Waveforms. . . . .	11
<b>Figure 7.</b>	PowerSO-10™ PC board. . . . .	12
<b>Figure 8.</b>	$R_{th(JA)}$ vs PBC copper area in open box free air condition. . . . .	12
<b>Figure 9.</b>	Reverse polarity protection. . . . .	13
<b>Figure 10.</b>	PowerSO-10™ package dimensions . . . . .	15
<b>Figure 11.</b>	PowerSO-10™ suggested pad and tube shipment (no suffix) . . . . .	15
<b>Figure 12.</b>	PowerSO-10™ tape and reel shipment (suffix “TR”) . . . . .	16
<b>Figure 13.</b>	SO20 mechanical data and package dimensions . . . . .	17
<b>Figure 14.</b>	SO20 tube shipment (no suffix). . . . .	18
<b>Figure 15.</b>	SO20 Tape and reel shipment (suffix “13TR”) . . . . .	19

## List of tables

<b>Table 1.</b>	Absolute maximum ratings . . . . .	3
<b>Table 2.</b>	Thermal data . . . . .	4
<b>Table 3.</b>	Pin connection . . . . .	5
<b>Table 4.</b>	Power section . . . . .	6
<b>Table 5.</b>	Switching ( $V_{CC} = 24\text{ V}$ , $R_{LOAD} = 96\ \Omega$ ) . . . . .	6
<b>Table 6.</b>	Protections (per channels) . . . . .	7
<b>Table 7.</b>	Logic Input (per channel) . . . . .	7
<b>Table 8.</b>	Status pin . . . . .	8
<b>Table 9.</b>	$V_{CC}$ - output diode . . . . .	8
<b>Table 10.</b>	Truth table . . . . .	9
<b>Table 11.</b>	PowerSO-10™ mechanical data . . . . .	14
<b>Table 12.</b>	Ordering information. . . . .	20
<b>Table 13.</b>	Document revision history . . . . .	21



**IMPORTANT NOTICE – PLEASE READ CAREFULLY**

STMicroelectronics NV and its subsidiaries (“ST”) reserve the right to make changes, corrections, enhancements, modifications, and improvements to ST products and/or to this document at any time without notice. Purchasers should obtain the latest relevant information on ST products before placing orders. ST products are sold pursuant to ST’s terms and conditions of sale in place at the time of order acknowledgement.

Purchasers are solely responsible for the choice, selection, and use of ST products and ST assumes no liability for application assistance or the design of Purchasers’ products.

No license, express or implied, to any intellectual property right is granted by ST herein.

Resale of ST products with provisions different from the information set forth herein shall void any warranty granted by ST for such product.

ST and the ST logo are trademarks of ST. For additional information about ST trademarks, please refer to [www.st.com/trademarks](http://www.st.com/trademarks). All other product or service names are the property of their respective owners.

Information in this document supersedes and replaces information previously supplied in any prior versions of this document.

© 2021 STMicroelectronics – All rights reserved