



Powered-off Protection, High Speed, 1.65 V to 5.5 V, SPDT Analog Switch (2:1 Multiplexer / Demultiplexer Bus Switch)

DESCRIPTION

The DG3157E is a high speed single-pole double-throw analog switch designed for +1.65 V to +5.5 V single power rail operation.

Fabricated with high density CMOS technology, the DG3157E achieves low on-resistance, fast switching speed, and high bandwidth while maintains low power consumption.

The DG3157E can handle both analog and digital signals and permits signals with amplitudes of up to V+ to be transmitted in either direction.

When the select pin is low, B₀ is connected to the output A pin. When the select pin is high, B₁ is connected to the output A pin. The path that is open will have a high impedance state with respect to the output. Break before make switching performance is guaranteed.

A powered-off protection circuit is built into the switch to prevent an abnormal current flow from COM pin to V+ during the power-down condition. Each output pin can withstand greater than 7 kV (human body model).

Operation temperature is specified from -40 °C to +85 °C. The DG3157E is available in the compact SC-70-6L package.

FEATURES

- Direct cross to industry standard SN74LVC1G3157, NC7SB3157, NLASB3157, PI5A3157, and STG3157
- Low switch on-resistance (6 Ω)
- +1.65 V to +5.5 V single supply operation
- Powered-off protection
- Control logic inputs can go over V+ up to 5.5 V
- Low parasitic capacitance, 7 pF at switch off
- Break before make switching
- Latch-up performance exceeds 200 mA per JESD 78
- High ESD rating
 - 7000 V human body model (JS-001)
 - 1000 V charge device model (JS-002)
- Material categorization: for definitions of compliance please see www.vishay.com/doc?99912



APPLICATIONS

- Battery powered devices
- Consumer and computing
- Instrumentation
- Medical equipment
- Control and automation

FUNCTIONAL BLOCK DIAGRAM AND PIN CONFIGURATION

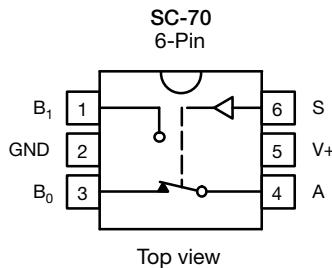

Device marking: H0

| TRUTH TABLE | |
|-----------------|-------------------------------|
| LOGIC INPUT (S) | FUNCTION |
| 0 | B ₀ connected to A |
| 1 | B ₁ connected to A |

| ORDERING INFORMATION | | |
|----------------------|---------|------------------------------------|
| TEMP. RANGE | PACKAGE | PART NUMBER |
| -40 °C to +85 °C | SC-70-6 | DG3157EDL-T1-GE3 (halogen-free) |



| ABSOLUTE MAXIMUM RATINGS | | | |
|-------------------------------------------------------------|----------------------------------------------------|-------------|------|
| PARAMETER | | LIMIT | UNIT |
| V+, A, B ₀ , B ₁ , S reference to GND | | -0.3 to 6 | V |
| Continuous current (any terminal) | | ± 50 | mA |
| Peak current (pulsed at 1 ms, 10 % duty cycle) | | ± 200 | |
| Storage temperature | D suffix | -65 to +150 | °C |
| Power dissipation (packages) ^a | 6-pin SC-70 ^b | 250 | mW |
| ESD / HBM | JS-001 | 7000 | V |
| ESD / CDM | JS-002 | 1000 | |
| Latch up | Per JEDEC78 with 1.5 x V _{abs} max. clamp | 200 | mA |

Notes

- a. All leads welded or soldered to PC board
- b. Derate 3.1 mW/°C above 70 °C

Stresses beyond those listed under "Absolute Maximum Ratings" may cause permanent damage to the device. These are stress ratings only, and functional operation of the device at these or any other conditions beyond those indicated in the operational sections of the specifications is not implied. Exposure to absolute maximum rating conditions for extended periods may affect device reliability.

| SPECIFICATIONS | | | | | | | | |
|--------------------------------------------------|----------------------|--------------------------------------------------------------------------------------------------------------------------------------------------------------------------------------------------|---------------------------------------------------------------|--------------------|----------------------------|-------------------|-------------------|------|
| PARAMETER | SYMBOL | TEST CONDITIONS UNLESS OTHERWISE SPECIFIED V _S = 0.25 V+ or 0.75 V+, V+ = 1.65 V to 1.95 V ^e V _S = 0.2 V+ or 0.65 V+, V+ = 2.3 V to 5.5 V ^e | | TEMP. ^a | LIMITS -40 °C to +85 °C | | | UNIT |
| | | | | | MIN. ^b | TYP. ^c | MAX. ^b | |
| DC Characteristics | | | | | | | | |
| High level input voltage | V _{SH} | V+ = 1.65 V to 1.95 V | | Full | 0.75 V+ | - | - | V |
| | | V+ = 2.3 V to 5.5 V | | Full | 0.65 V+ | - | - | |
| Low level input voltage | V _{SL} | V+ = 1.65 V to 1.95 V | | Full | - | - | 0.25 V+ | V |
| | | V+ = 2.3 V to 5.5 V | | Full | - | - | 0.2 V+ | |
| On resistance | R _{ON} | V+ = 4.5 V | V _{BN} = 0 V, I _A = 30 mA | Full | - | 8 | 11 | Ω |
| | | | V _{BN} = 2.3 V, I _A = -30 mA | Full | - | 6 | 9 | |
| | | | V _{BN} = 4.5 V, I _A = -30 mA | Full | - | 7 | 9 | |
| | | V+ = 3 V | V _{BN} = 0 V, I _A = 24 mA | Full | - | 10 | 14 | |
| | | | V _{BN} = 3 V, I _A = -24 mA | Full | - | 9 | 12 | |
| | | V+ = 2.3 V | V _{BN} = 0 V, I _A = 8 mA | Full | - | 13 | 18 | |
| | | | V _{BN} = 2.3 V, I _A = -8 mA | Full | - | 12 | 16 | |
| | | V+ = 1.65 V | V _{BN} = 0 V, I _A = 4 mA | Full | - | 20 | 26 | |
| V _{BN} = 1.65 V, I _A = -4 mA | Full | | - | 18 | 23 | | | |
| On resistance flatness | R _{FLAT} | 0 < V _{BN} < V+ | V+ = 4.5 V, I _A = -30 mA | Room | - | 2 | - | |
| | | | V+ = 3 V, I _A = -24 mA | Room | - | 4 | - | |
| | | | V+ = 2.3 V, I _A = -8 mA | Room | - | 10 | - | |
| | | | V+ = 1.65 V, I _A = -4 mA | Room | - | 58 | - | |
| On resistance matching between channels | ΔR _{ON} | | V+ = 4.5 V, V _{BN} = 3.15 V, I _A = -30 mA | Room | - | 0.09 | - | |
| | | | V+ = 3 V, V _{BN} = 2.1 V, I _A = -24 mA | Room | - | 0.13 | - | |
| | | | V+ = 2.3 V, V _{BN} = 1.6 V, I _A = -8 mA | Room | - | 0.15 | - | |
| | | | V+ = 1.65 V, V _{BN} = 1.15 V, I _A = -4 mA | Room | - | 0.16 | - | |
| Input leakage current | I _S | V+ = 5.5 V, V _S = 5.5 V | Room | -0.1 | - | 0.1 | μA | |
| | | | Full | -1 | - | 1 | | |
| Off stage switch leakage | I _{BN(off)} | V+ = 5.5 V, V _A = 1 V / 4.5 V, V _B = 4.5 V / 1 V | Room | -0.1 | - | 0.1 | μA | |
| | | | Full | -1 | - | 1 | | |
| On state switch leakage | I _{BN(on)} | V+ = 5.5 V, V _A = V _B = 1 V or 4.5 V | Room | -0.1 | - | 0.1 | μA | |
| | | | Full | -1 | - | 1 | | |
| Power down leakage | I _{PD} | V+ = 0 V, V _A = 5 V, B ₀ , B ₁ open, V _S = GND | Full | - | - | 5 | μA | |
| | | V+ = 0 V, V _{B0} , V _{B1} = 5 V, A open, V _S = GND | Full | - | - | 5 | | |
| Power Supply | | | | | | | | |
| Power supply range | V+ | | | Full | 1.65 | - | 5.5 | V |
| Quiescent supply current | I+ | V+ = 5.5 V, V _S = V+ or GND | Room | - | - | 1 | μA | |
| | | | Full | - | - | 5 | | |



| SPECIFICATIONS | | | | | | | | |
|----------------------------------------------------|-------------------|----------------------------------------------------------------------------------------------------------------------------------------------------------------------------------------------|---------------------------|----------------------------|-------------------|-------------------|------|----|
| PARAMETER | SYMBOL | TEST CONDITIONS UNLESS OTHERWISE SPECIFIED $V_S = 0.25 V+$ or $0.75 V+$, $V+ = 1.65 V$ to $1.95 V$ ^e $V_S = 0.2 V+$ or $0.65 V+$, $V+ = 2.3 V$ to $5.5 V$ ^e | TEMP. ^a | LIMITS -40 °C to +85 °C | | | UNIT | |
| | | | | MIN. ^b | TYP. ^c | MAX. ^b | | |
| AC Electrical Characteristics ^e | | | | | | | | |
| Prop delay time ^f | t_{PHL}/t_{PLH} | $V_A = 0 V$, see Fig. 3 | $V+ = 1.65 V$ to $1.95 V$ | Full | - | 4 | - | ns |
| | | | $V+ = 2.3 V$ to $2.7 V$ | Full | - | 3 | - | |
| | | | $V+ = 3 V$ to $3.6 V$ | Full | - | 2 | - | |
| | | | $V+ = 4.5 V$ to $5.5 V$ | Full | - | 2 | - | |
| Output enable time ^f | t_{PZL}/t_{PZH} | $V_{LOAD} = 2 \times V+$ for t_{PZL} , $V_{LOAD} = 0 V$ for t_{PZH} , see Fig. 4 | $V+ = 1.65 V$ to $1.95 V$ | Room | - | 32 | - | |
| | | | | Full | - | 34 | - | |
| | | | $V+ = 2.3 V$ to $2.7 V$ | Room | - | 22 | - | |
| | | | | Full | - | 23 | - | |
| | | | $V+ = 3 V$ to $3.6 V$ | Room | - | 19 | - | |
| | | | | Full | - | 20 | - | |
| | | | $V+ = 4.5 V$ to $5.5 V$ | Room | - | 16 | - | |
| | | | | Full | - | 16 | - | |
| Output disable time ^f | t_{PLZ}/t_{PHZ} | $V_{LOAD} = 2 \times V+$ for t_{PLZ} , $V_{LOAD} = 0 V$ for t_{PHZ} , see Fig. 4 | $V+ = 1.65 V$ to $1.95 V$ | Room | - | 22 | - | |
| | | | | Full | - | 23 | - | |
| | | | $V+ = 2.3 V$ to $2.7 V$ | Room | - | 18 | - | |
| | | | | Full | - | 19 | - | |
| | | | $V+ = 3 V$ to $3.6 V$ | Room | - | 16 | - | |
| | | | | Full | - | 16 | - | |
| | | | $V+ = 4.5 V$ to $5.5 V$ | Room | - | 13 | - | |
| | | | | Full | - | 14 | - | |
| Break-before-make time ^d | t_{BBM} | | $V+ = 1.65 V$ to $1.95 V$ | Full | 0.5 | - | - | |
| | | | $V+ = 2.3 V$ to $2.7 V$ | Full | 0.5 | - | - | |
| | | | $V+ = 3 V$ to $3.65 V$ | Full | 0.5 | - | - | |
| | | | $V+ = 4.5 V$ to $5.5 V$ | Full | 0.5 | - | - | |
| Charge injection ^d | Q | $C_L = 0.1 nF$, $V_{GEN} = 0 V$ $R_{GEN} = 0 \Omega$ | $V+ = 5 V$ | Room | - | 1.3 | - | pC |
| | | | $V+ = 3.3 V$ | Room | - | 0.5 | - | |
| Analog Switch Characteristics | | | | | | | | |
| Off isolation ^d | OIRR | $R_L = 50 \Omega$, $f = 10 MHz$ | Room | - | -61 | - | dB | |
| Crosstalk ^d | X_{TALK} | | Room | - | -61 | - | | |
| -3 dB bandwidth ^d | BW | $R_L = 50 \Omega$ | Room | - | 580 | - | MHz | |
| Capacitance | | | | | | | | |
| Control pin capacitance ^d | C_{IN} | $V+ = 0 V$ | Room | - | 6 | - | pF | |
| B port off capacitance ^d | C_{IO-B} | $V+ = 5 V$ | Room | - | 7 | - | | |
| A port capacitance when switch enable ^d | $C_{IO-A(on)}$ | | Room | - | 12 | - | | |

Notes

- a. Room = 25 °C, full = as determined by the operating suffix
- b. The algebraic convention whereby the most negative value is a minimum and the most positive a maximum, is used in this datasheet
- c. Typical values are for design aid only, not guaranteed nor subject to production testing
- d. Guarantee by design, nor subjected to production test
- e. V_S = input voltage to perform proper function
- f. Guaranteed by design and not production tested. The bus switch propagation delay is a function of the RC time constant contributed by the on-resistance and the specified load capacitance with an ideal voltage source (zero output impedance) driving the switch

LOGIC DIAGRAM POSITIVE LOGIC

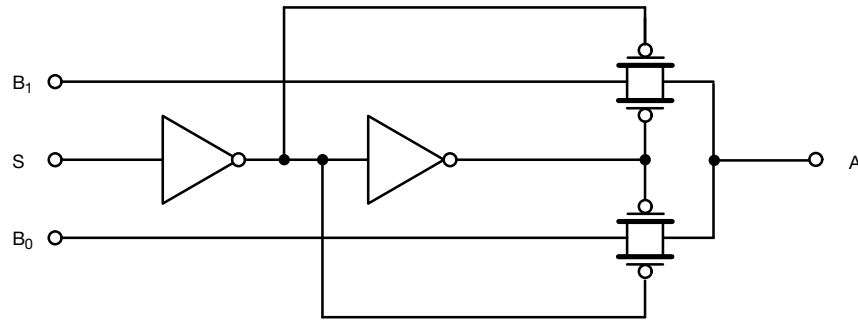
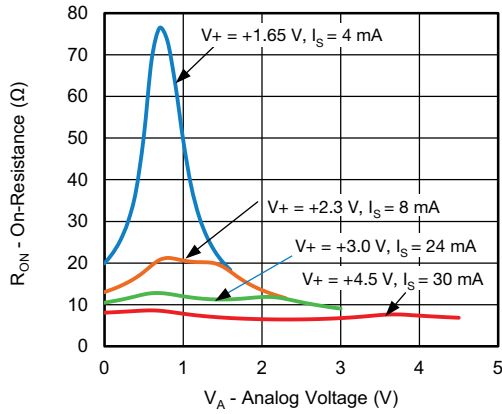
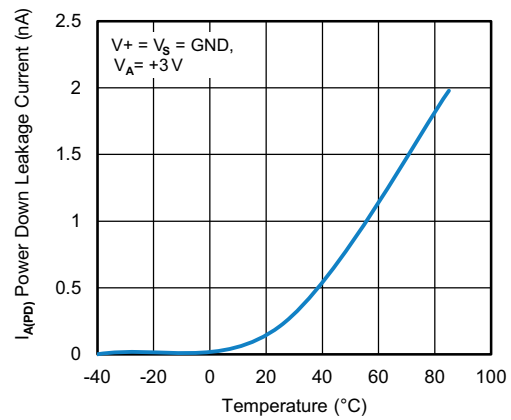

Fig. 1

TYPICAL CHARACTERISTICS (25 °C, unless otherwise noted)



R_{ON} vs. V_A vs. V+



Power Down Leakage Current vs. Temperature

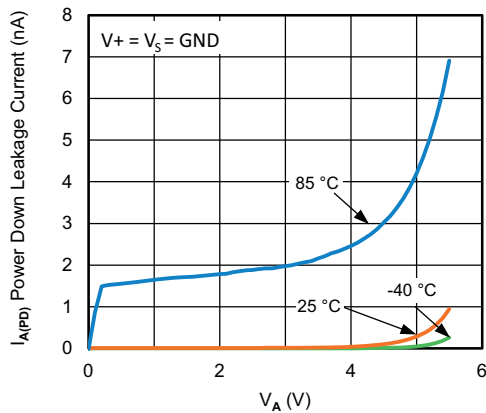

Power Down Leakage Current vs. V_A

AC LOADING AND WAVEFORMS

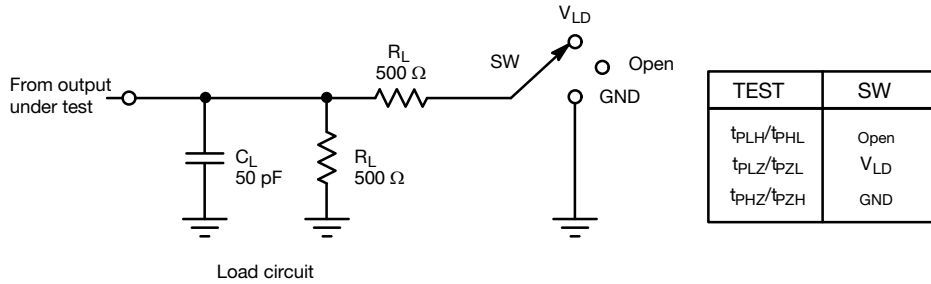
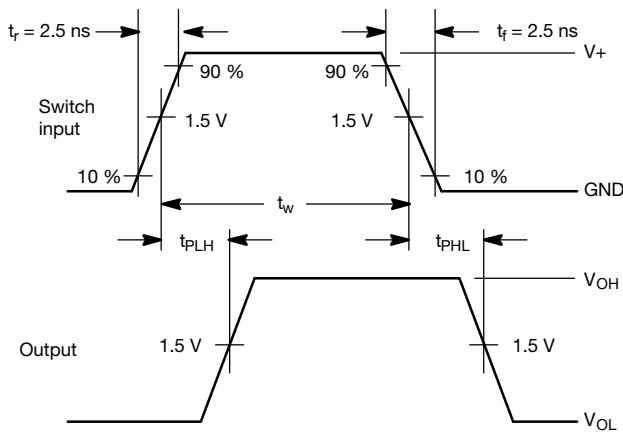
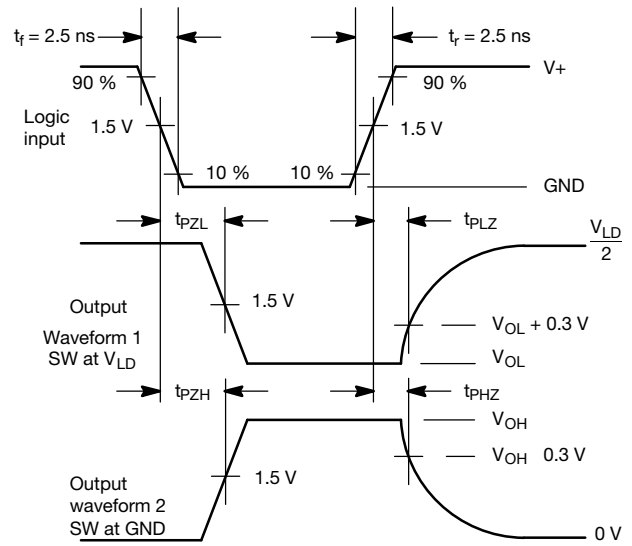

Fig. 2 - AC Test Circuit



Propagation delay times

Fig. 3 - AC Waveforms



Enable and disable time-low- and high-level enabling

Fig. 4 - AC Waveforms

Notes

- C_L includes probe and jig capacitance
- Waveform 1 is for an output with internal conditions such that the output is low except when disabled by the output control
- Waveform 2 is for an output with internal conditions such that the output is high except when disabled by the output control.
- All input pulses are supplied by generators having the following characteristics: $PRR \leq 10$ MHz, $Z_O = 50 \Omega$
- The outputs are measured one at a time with one transition per measurement
- t_{PLZ} and t_{PHZ} are the same as t_{dis}
- t_{PZL} and t_{PZH} are the same as t_{dis}
- t_{PLH} and t_{PHL} are the same as t_{dis}
- $V_{LD} = 2$ V+

TEST CIRCUITS

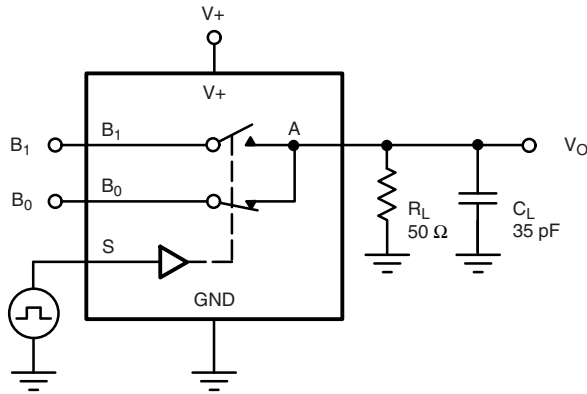

C_L (includes fixture and stray capacitance)

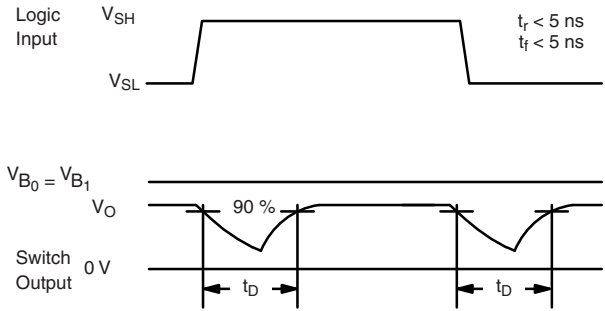
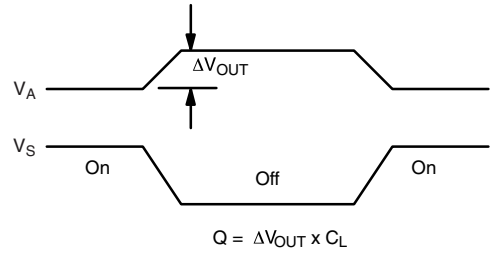
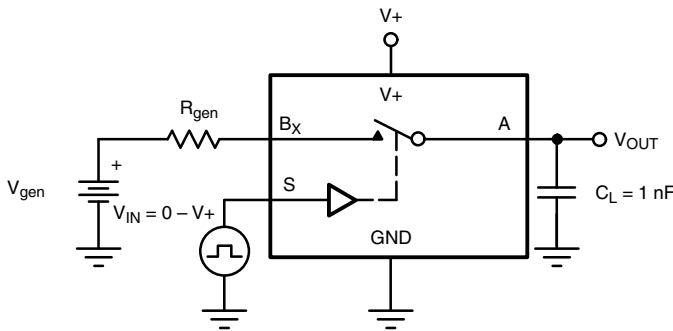
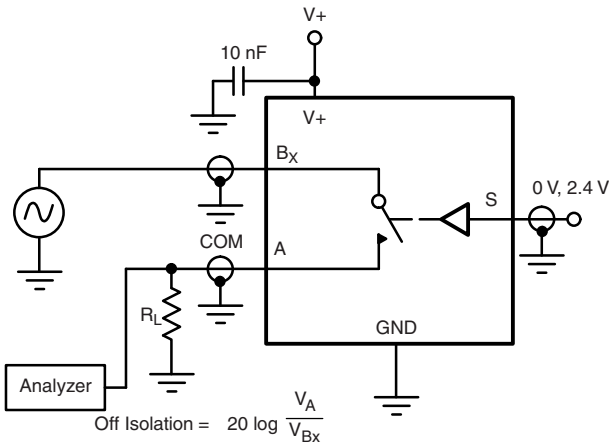

Fig. 5 - Break-Before-Make Interval



IN depends on switch configuration: input polarity determined by sense of switch.

Fig. 6 - Charge Injection



$$\text{Off Isolation} = 20 \log \frac{V_A}{V_{Bx}}$$

Fig. 7 - Off-Isolation

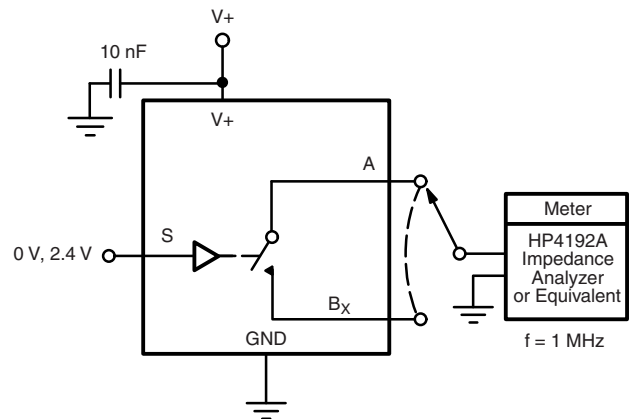

Fig. 8 - Channel Off/On Capacitance

Vishay Siliconix maintains worldwide manufacturing capability. Products may be manufactured at one of several qualified locations. Reliability data for Silicon Technology and Package Reliability represent a composite of all qualified locations. For related documents such as package / tape drawings, part marking, and reliability data, see www.vishay.com/ppg?76387.



Disclaimer

ALL PRODUCT, PRODUCT SPECIFICATIONS AND DATA ARE SUBJECT TO CHANGE WITHOUT NOTICE TO IMPROVE RELIABILITY, FUNCTION OR DESIGN OR OTHERWISE.

Vishay Intertechnology, Inc., its affiliates, agents, and employees, and all persons acting on its or their behalf (collectively, "Vishay"), disclaim any and all liability for any errors, inaccuracies or incompleteness contained in any datasheet or in any other disclosure relating to any product.

Vishay makes no warranty, representation or guarantee regarding the suitability of the products for any particular purpose or the continuing production of any product. To the maximum extent permitted by applicable law, Vishay disclaims (i) any and all liability arising out of the application or use of any product, (ii) any and all liability, including without limitation special, consequential or incidental damages, and (iii) any and all implied warranties, including warranties of fitness for particular purpose, non-infringement and merchantability.

Statements regarding the suitability of products for certain types of applications are based on Vishay's knowledge of typical requirements that are often placed on Vishay products in generic applications. Such statements are not binding statements about the suitability of products for a particular application. It is the customer's responsibility to validate that a particular product with the properties described in the product specification is suitable for use in a particular application. Parameters provided in datasheets and / or specifications may vary in different applications and performance may vary over time. All operating parameters, including typical parameters, must be validated for each customer application by the customer's technical experts. Product specifications do not expand or otherwise modify Vishay's terms and conditions of purchase, including but not limited to the warranty expressed therein.

Hyperlinks included in this datasheet may direct users to third-party websites. These links are provided as a convenience and for informational purposes only. Inclusion of these hyperlinks does not constitute an endorsement or an approval by Vishay of any of the products, services or opinions of the corporation, organization or individual associated with the third-party website. Vishay disclaims any and all liability and bears no responsibility for the accuracy, legality or content of the third-party website or for that of subsequent links.

Except as expressly indicated in writing, Vishay products are not designed for use in medical, life-saving, or life-sustaining applications or for any other application in which the failure of the Vishay product could result in personal injury or death. Customers using or selling Vishay products not expressly indicated for use in such applications do so at their own risk. Please contact authorized Vishay personnel to obtain written terms and conditions regarding products designed for such applications.

No license, express or implied, by estoppel or otherwise, to any intellectual property rights is granted by this document or by any conduct of Vishay. Product names and markings noted herein may be trademarks of their respective owners.