

PART NUMBER	SSL-LX5093TC	REV.	A
DATE	E.C.N. NUMBER AND REVISION COMMENTS		REV.
10.02.12	E.C.N. #10BRDR. & REDRAWN.		A

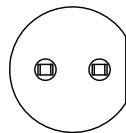
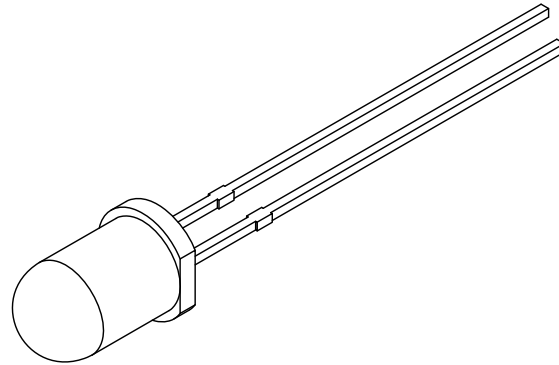
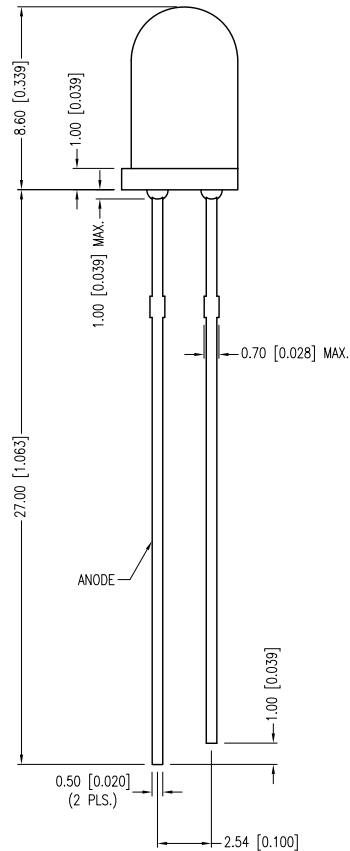
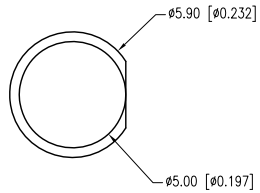

ELECTRO-OPTICAL CHARACTERISTICS Ta=25°C If=20mA

PARAMETER	MIN	TYP	MAX	UNITS	TEST COND
PEAK WAVELENGTH	-	-	-	nm	
FORWARD VOLTAGE	-	3.2	4.0	Vf	If=20mA
REVERSE VOLTAGE	5.0	-	-	Vr	Ir=10μA
AXIAL INTENSITY	900	2200	-	mcd	If=20mA
CHROMATICITY (X)	-	0.19	-	-	
COORDINATES (Y)**	-	0.41	-	-	If=20mA
VIEWING ANGLE	-	20	-	2x theta	
EMITTED COLOR:	TURQUOISE				
LENS FINISH:	WATER CLEAR				

*AXIAL INTENSITY TESTING CONDITION 550nm WAVELENGTH.
 **THE ICI STANDARD COLORIMETRIC SYSTEM.

LIMITS OF SAFE OPERATION AT 25°C

PARAMETER	SYMBOL	MAX	UNITS
PULSE FORWARD CURRENT*	IP	100	mA
STEADY CURRENT	If	30	mA
POWER DISSIPATION	Pd	120	mW
OPERATING TEMP.	ToPR	-40 TO +85	°C
STORAGE TEMP.	Tstg	-40 TO +85	°C
SOLDER TEMP.	-	+260	°C
2.0mm FROM BODY	-	3	SEC.

*DUTY 1/10 PULSE WIDTH 10ms
 CAUTION: STATIC SENSITIVE DEVICE
 FOLLOW PROPER E.S.D. HANDLING PROCEDURES
 WHEN WORKING WITH THIS PART.

*UNLESS OTHERWISE SPECIFIED TOLERANCES PER DECIMAL PRECISION ARE: X=±1 (±0.039), X.X=±0.5 (±0.020), X.XX=±0.25 (±0.010), X.XXX=±0.127 (±0.005). LEAD SIZE=±0.05 (±0.002), LEAD LENGTH=±0.75 (±0.030). MIN.= +DECIMAL PRECISION MAX.= +0.00 -DECIMAL PRECISION



425 N. GARY AVE.
 CAROL STREAM, IL 60188-4900
 PHONE: +1.800.278.5666
 FAX: +1.630.315.2152
 WEB: WWW.LUMEX.COM
 MEMBER OF ITW PHOTONICS GROUP

QUASARBRITE T-5mm (T-1 3/4) TURQUOISE LED, WATER CLEAR LENS.

THE SPECIFICATIONS MAY CHANGE AT ANY TIME WITHOUT NOTICE DUE TO NEW MATERIALS OR PRODUCT IMPROVEMENT.

CONFIDENTIAL INFORMATION
 THE INFORMATION CONTAINED IN THIS DOCUMENT IS THE PROPERTY OF LUMEX INC. EXCEPT AS SPECIFICALLY AUTHORIZED IN WRITING BY LUMEX INC., THE HOLDER OF THIS DOCUMENT SHALL KEEP ALL INFORMATION CONTAINED HEREIN CONFIDENTIAL AND SHALL PROTECT SAME IN WHOLE OR IN PART FROM DISCLOSURE AND DISSEMINATION TO ALL THIRD PARTIES.

DATE:	10.02.12	DRAWN BY:	AB
PAGE:	1 OF 1	CHKD BY:	KF
SCALE:	NTS	APRVD BY:	KF
UNIT:	mm [INCH]		Ⓟ