

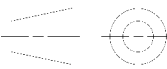

POS	QTY	TE P/N	REV	DESCRIPTION	S=Spare Parts S W W=Wear Parts
1	1	6-1579019-8	C	DIE SET HV CONTACTS AK CAT1	<input checked="" type="checkbox"/> <input type="checkbox"/>
2	1	6-563080-0	A	TOOL ASSEMBLY INCL. LOC., HVA630	<input checked="" type="checkbox"/> <input type="checkbox"/>
3	1	519719-3	A	STOP PLATE	<input checked="" type="checkbox"/> <input type="checkbox"/>
4	1	9-519637-2	A	TYPE PLATE, HV TOOLING	<input checked="" type="checkbox"/> <input type="checkbox"/>
5	2	2168078-1	A	SCREW,DRIVE,ROUND HD,METALLIC,	<input checked="" type="checkbox"/> <input type="checkbox"/>

REMARKS:	USED ON -
----------	--------------

P	LTR	REVISION RECORD	DATE	DWN	APVD	PRINTED	DWN	30JUN11	CHK	30JUN11	APVD	30JUN11
-	-	SEE SHEET 1	-	-	-	14AUG19	G.Sowa		G.Sowa		G.Stegmayer	

<p>THIS DRAWING IS UNPUBLISHED. RELEASED FROM PUBLICATION -,- ©COPYRIGHT - BY TYCO ELECTRONICS CORPORATION. ALL INTERNATIONAL RIGHT RESERVED.</p>			CUSTOMER PART LIST		 TE connectivity TE Connectivity		
	NAME						RESTRICTED TO
	DIE SET LOCATOR HVA630 2PHM,4.0 SQMM						-
SCALE	SIZE	DRAWING NO		SHEET	REV		
-	A4	C-528041-9		2 / 3	F1		

LOC		DIST		REVISIONS			
P	LTR	DESCRIPTION	DATE	DWN	APVD		
		SEE SHEET 1					

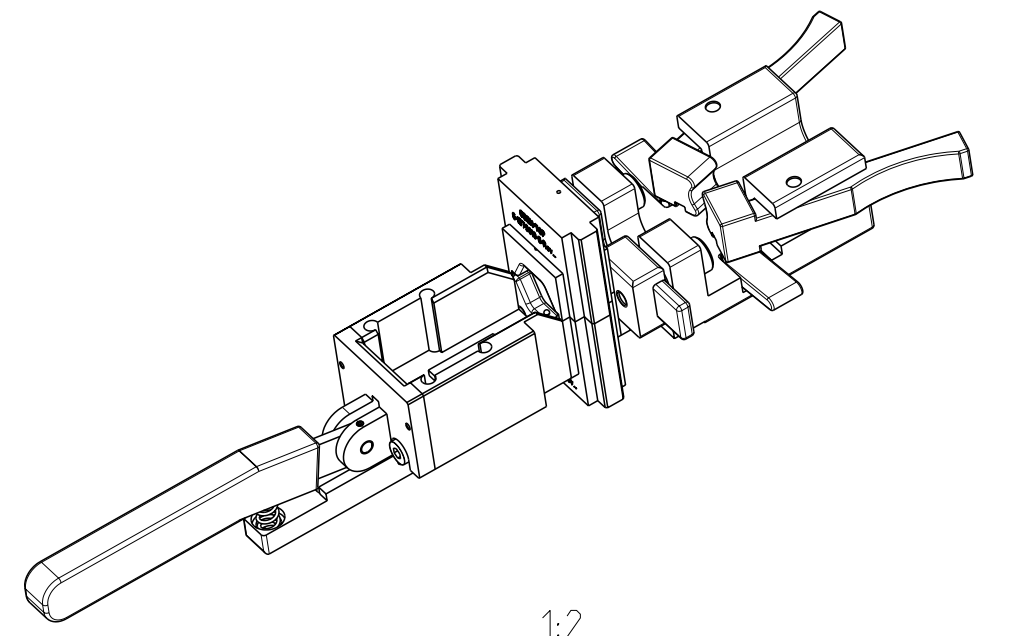
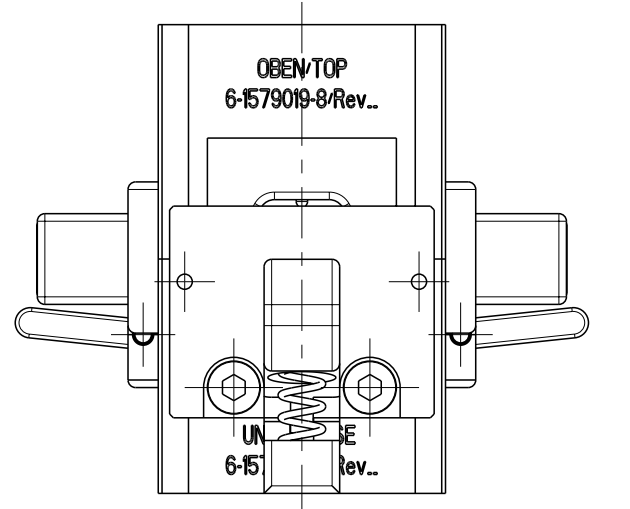
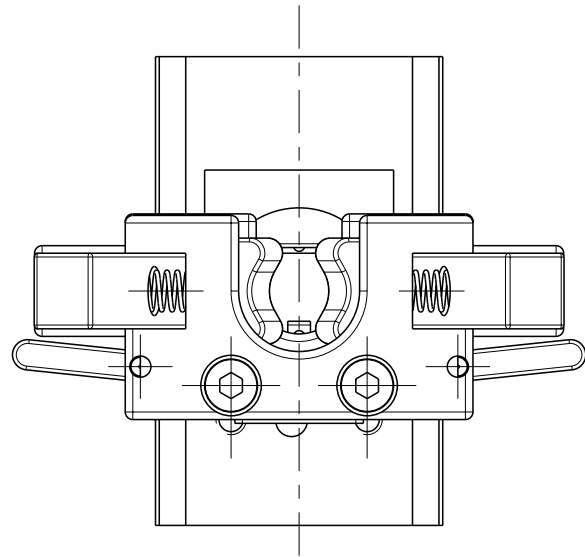
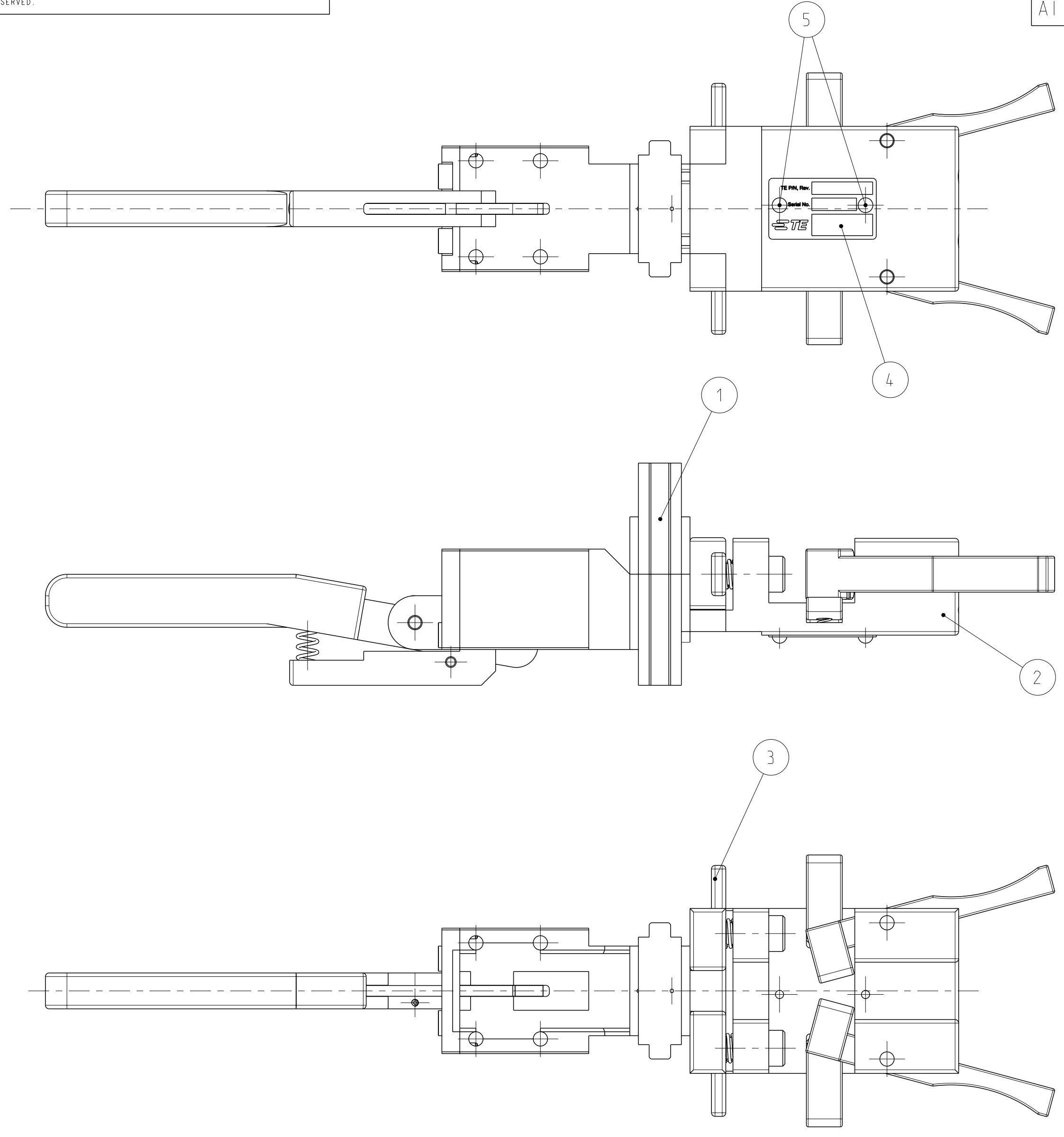

1:2

Matrize in Kombination mit hydraulischer Handzange TE PN 9-1579009-1 verwendbar
 Use this die set in combination with hydraulic tool TE PN 9-1579009-1

THIS DRAWING IS A CONTROLLED DOCUMENT.		DWN	G.Sowa	30JUN2011	 TE Connectivity	NAME		DIE SET, LOCATOR HVA630 2PHM.4.0 SQMM				
DIMENSIONS:		CHK	G.Sowa	30JUN2011		Matrize. Aufnahme HVA630 2PHM.4.0 qmm		SIZE	CAGE CODE	DRAWING NO		
mm		APVD	G.Sowa	30JUN2011		-		A2	00779	C=528041-9		
TOLERANCES UNLESS OTHERWISE SPECIFIED:		PRODUCT SPEC	-			APPLICATION SPEC		-		RESTRICTED TO		
0 PLC ± 1 PLC ± 2 PLC ± 3 PLC ± 4 PLC ± ANGLES ±1° FINISH		WEIGHT	-		CUSTOMER DRAWING		SCALE	1:1	SHEET	3 OF 3	REV	F1