

Tous droits strictement réservés. Reproduction ou communication a des tiers interdite sous quelque forme que ce soit sans autorisation écrite du propriétaire. Propriété de c.FCI. Droits de reproduction FCI.

All rights strictly reserved. Reproduction or issue to third parties in any form whatever is not permitted without written authority from the proprietor. Property of FCI. Copyright FCI.

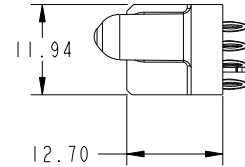

|                        |                  |       |    |        |   |   |   |   |       |    |    |    |    |    |    |    |
|------------------------|------------------|-------|----|--------|---|---|---|---|-------|----|----|----|----|----|----|----|
| PRODUCT NO.            | ROWS             | POWER |    | SIGNAL |   |   |   |   | POWER |    |    |    |    | E1 |    |    |
|                        |                  | E2    | P8 | P7     | 5 | 4 | 3 | 2 | 1     | P6 | P5 | P4 | P3 |    | P2 | P1 |
| 51940-209--<br>NOTE: 3 | D<br>C<br>B<br>A |       | PF | PF     | F | F | F | F | F     | F  | F  | F  | F  | F  | F  |    |

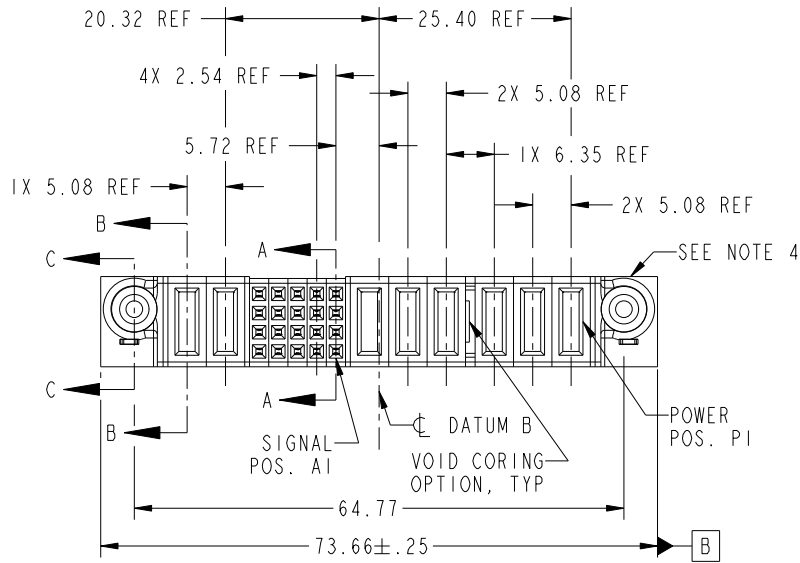

| CODE | DIM "M" MATING LENGTH | CONTACT TYPE |
|------|-----------------------|--------------|
| PF   | [2.34]                | POWER        |
| F    | [N/A]                 | SIGNAL       |
| HA   | [N/A]                 | HOLD-DOWN    |

|             |                |       |          |           |               |                                       |            |          |  |                        |        |
|-------------|----------------|-------|----------|-----------|---------------|---------------------------------------|------------|----------|--|------------------------|--------|
| mat'l code  |                |       |          | SEE NOTES |               | tolerances unless otherwise specified |            | CUSTOMER |  | <br>www.fciconnect.com |        |
| lir         | ecn no.        | dr    | date     | linear    | 0.X ± 0.3     |                                       | COPY       |          | title<br>6P + 20S + 2P<br>VERTICAL PF RECEPT |                        |        |
| A           | DG07-0025      | JULIA | 01/17/07 |           | 0.XX ± 0.13   |                                       | projection |          |  |                        |        |
|             |                |       |          |           | 0.XXX ± 0.051 |                                       | <br>MM     |          |  |                        |        |
|             |                |       |          | angles    | 0° ± 2°       |                                       | <br>1:1    |          | product family                               |                        | code   |
|             |                |       |          | dr        | JULIA WANG    | 11/15/06                              | PwrBlade   |          | size   | dwg no                 | 213    |
|             |                |       |          | engr      | RYAN YUAN     | 11/15/06                              | A          |          | 51940-209                                    |                        | sheet  |
|             |                |       |          | chr       | BEER FU       | 11/15/06                              | A          |          |  |                        | 1 of 4 |
|             |                |       |          | appd      | JOSEPH HSIA   | 11/15/06                              | A          |          |  |                        |        |
| sheet index | revision sheet | A     | A        | A         | A             | A                                     |            |          |  |                        |        |
|             |                | 1     | 2        | 3         | 4             |                                       |            |          |  |                        |        |

A

A

B

B

1 | 2

3

4

Pro/E

PDM: Rev: A

STAT: Released

Printed: Dec 20, 2010

cage code 2856

Tous droits strictement réservés. Reproduction ou communication a des tiers interdite sous quelque forme que ce soit sans autorisation écrite du propriétaire. Propriété de c FCI. Droits de reproduction FCI.

All rights strictly reserved. Reproduction or issue to third parties in any form whatever is not permitted without written authority from the proprietor. Property of FCI. Copyright FCI.



PRODUCT NUMBER

51940-209\_\_  
NOTE: 3

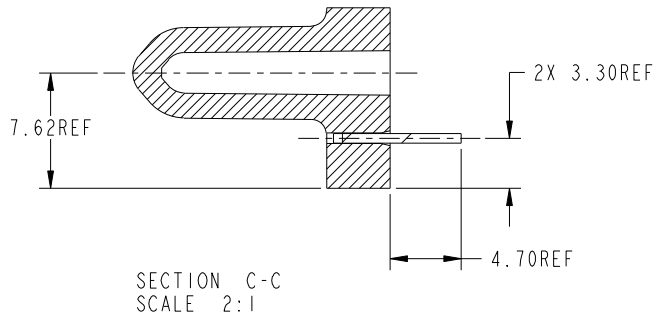
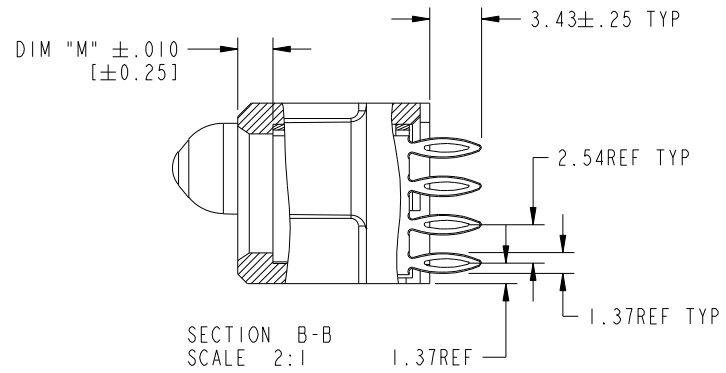
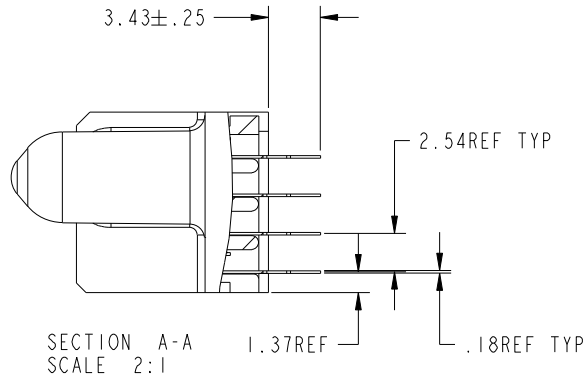

|             |                |    |      |                                       |                      |            |  |                        |  |
|-------------|----------------|----|------|---------------------------------------|----------------------|------------|--|------------------------|--|
| mat'l code  |                |    |      | tolerances unless otherwise specified |                      | CUSTOMER   |  | <br>www.fciconnect.com |  |
| lfr         | ecn no.        | dr | date | linear                                | 0.X ± 0.3            | COPY       |  | title                  |  |
| A           |                |    |      | linear                                | 0.XX ± 0.13          | projection |  | 6P + 20S + 2P          |  |
|             |                |    |      | angles                                | 0.XXX ± 0.051        |            |  | VERTICAL PF RECEIPT    |  |
|             |                |    |      | dr                                    | 0° ± 2°              |            |  | product family         |  |
|             |                |    |      | enrg                                  | JULIA WANG 11/15/06  | MM         |  | PwrBlade               |  |
|             |                |    |      | chr                                   | RYAN YUAN 11/15/06   | scale      |  | code                   |  |
|             |                |    |      | appd                                  | BEER FU 11/15/06     | 1:1        |  | 213                    |  |
|             |                |    |      |                                       | JOSEPH HSIA 11/15/06 |            |  | sheet                  |  |
| sheet index | revision sheet |    |      |                                       |                      |            |  | 2 of 4                 |  |
|             |                |    |      |                                       |                      |            |  | A 51940-209            |  |

cage code 2856

Pro/E

PDM: Rev: A

STATUS: Released

Printed: Dec 20, 2010

Tous droits strictement reserves. Reproduction ou communication a des tiers interdite sous quelque forme que ce soit sans autorisation ecrite du proprietaire. Propriete de c.FCI. Droits de reproduction FCI.

All rights strictly reserved. Reproduction or issue to third parties in any form whatever is not permitted without written authority from the proprietor. Property of FCI. Copyright FCI.



PRODUCT NUMBER

51940-209\_\_  
NOTE: 3

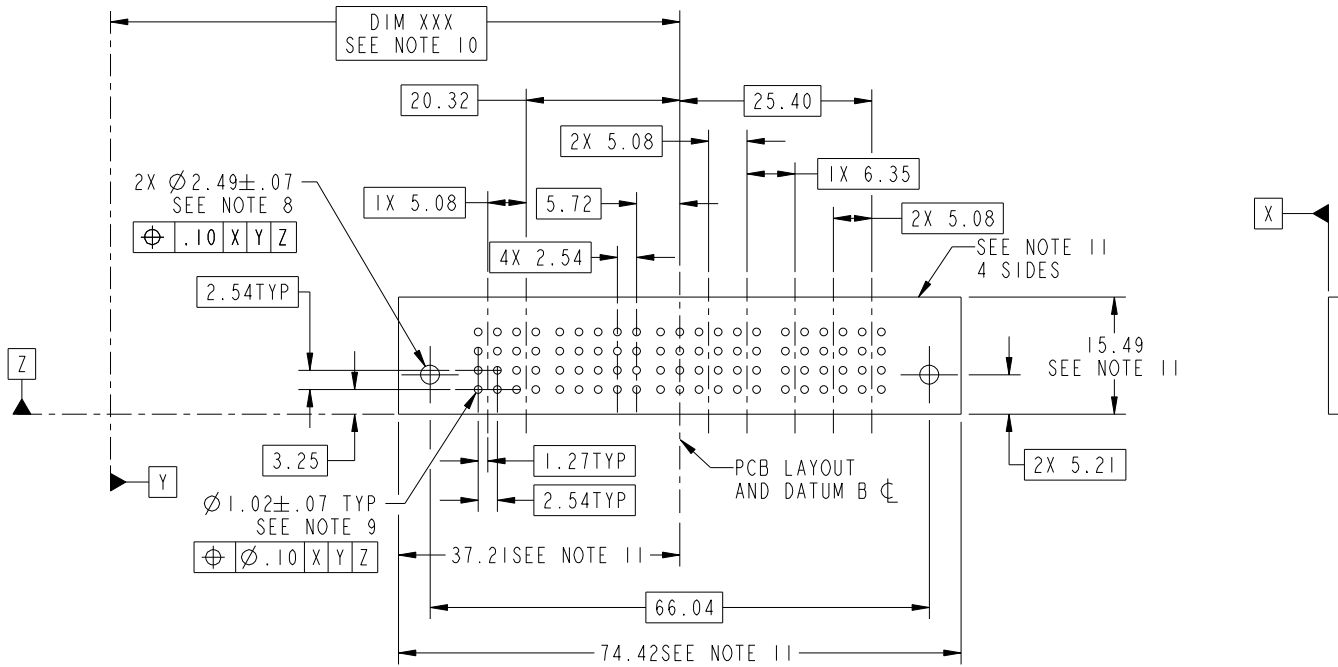

|             |         |                |      |                                       |                      |            |  |                                     |  |
|-------------|---------|----------------|------|---------------------------------------|----------------------|------------|--|-------------------------------------|--|
| mat'l code  |         |                |      | tolerances unless otherwise specified |                      | CUSTOMER   |  | FCI                                 |  |
| lir         | ecn no. | dr             | date | linear                                | 0.X ±0.3             | COPY       |  | www.fciconnect.com                  |  |
| A           |         |                |      | linear                                | 0.XX ±0.13           | projection |  | title                               |  |
|             |         |                |      | angles                                | 0.XXX ±0.051         | ⊕ ↗        |  | 6P + 20S + 2P<br>VERTICAL PF RECEPT |  |
|             |         |                |      |                                       | 0° ±2°               | MM         |  | product family                      |  |
|             |         |                |      | dr                                    | JULIA WANG 11/15/06  | scale      |  | PwrBlade                            |  |
|             |         |                |      | enr                                   | RYAN YUAN 11/15/06   | 1:1        |  | code                                |  |
|             |         |                |      | chr                                   | BEER FU 11/15/06     |            |  | 213                                 |  |
|             |         |                |      | appd                                  | JOSEPH HSIA 11/15/06 |            |  | sheet                               |  |
| sheet index |         | revision sheet |      |                                       |                      |            |  | 3 of 4                              |  |
|             |         |                |      |                                       |                      |            |  | 51940-209                           |  |

cage code 2856

Tous droits strictement réservés. Reproduction ou communication a des tiers interdite sous quelque forme que ce soit sans autorisation écrite du propriétaire. Propriété de c.FCI. Droits de reproduction FCI.

All rights strictly reserved. Reproduction or issue to third parties in any form whatever is not permitted without written authority from the proprietor. Property of FCI. Copyright FCI.



1 | 2

3

4

PRODUCT NUMBER

51940-209\_\_  
NOTE: 3

NOTES:

1. DIMENSIONS AND TOLERANCES ARE IN ACCORDANCE WITH ASME Y14.5M, 1994 UNLESS OTHERWISE SPECIFIED.

CONNECTOR NOTES:

- ② HOUSING MATERIAL: UL 94 V-0 GLASS FILLED  
HIGH-TEMP THERMOPLASTIC  
POWER CONTACT MATERIAL: COPPER ALLOY  
SIGNAL PIN MATERIAL: COPPER ALLOY
- 3. PLATING SPEC.  
51940-209,51940-209LF PLATING SPEC. WAS SHOWN IN THE PRINT OF 10064183.
- ④ MANUFACTURER'S NAME, P/N, AND DATE CODE TO APPEAR ON THIS SURFACE.
- 5. PRODUCT SPECIFICATION GS-12-149.  
APPLICATION SPECIFICATION BUS-20-067.
- 6. PACKAGED IN TRAYS.

PCB NOTES:

- 7. ALL HOLE DIAMETERS ARE FINISHED HOLE SIZE.
- ⑧ MOUNTING HOLES, WHERE APPLICABLE, ARE UNPLATED.
- ⑨  $\varnothing 1.151 \pm 0.025$  DRILLED HOLES PLATED WITH  
0.008 MIN SnPb OR Sn OVER 0.03  
TO 0.08 Cu PLATING TO ACHIEVE  
 $\varnothing 1.02 \pm .07$  HOLE.
- ⑩ "DIM XXX" TO BE DETERMINED BY THE CUSTOMER.
- ⑪ CONNECTOR KEEP-OUT ZONE.

|             |                |    |      |                                       |              |          |            |     |  |                    |  |
|-------------|----------------|----|------|---------------------------------------|--------------|----------|------------|-----|--|--------------------|--|
| mat'l code  |                |    |      | tolerances unless otherwise specified |              | CUSTOMER |            | FCI |  | www.fciconnect.com |  |
| lfr         | ecm no.        | dr | date | linear                                | 0.X ±0.3     |          | COPY       |     | title<br>6P + 20S + 2P<br>VERTICAL PF RECEPT                           |                    |  |
| A           |                |    |      |                                       | 0.XX ±0.13   |          | projection |     |  |                    |  |
|             |                |    |      |                                       | 0.XXX ±0.051 |          |            |     |  |                    |  |
|             |                |    |      | angles                                | 0° ±2°       |          |            |     | product family PwrBlade code 213<br>size dwg no 51940-209 sheet 4 of 4 |                    |  |
|             |                |    |      | dr                                    | JULIA WANG   | 11/15/06 | MM         |     |  |                    |  |
|             |                |    |      | enr                                   | RYAN YUAN    | 11/15/06 | scale      |     |  |                    |  |
|             |                |    |      | chr                                   | BEER FU      | 11/15/06 | 1:1        |     |  |                    |  |
|             |                |    |      | appd                                  | JOSEPH HSIA  | 11/15/06 |            |     |  |                    |  |
| sheet index | revision sheet |    |      |                                       |              |          |            |     |  |                    |  |

1 | 2

Pro/E

PDM: Rev: A

STATUS: Released

Printed: Dec 20, 2010

cage code 2856

4