

## Description

Single pole thermal circuit breaker with push-to-reset, tease-free, trip-free, snap action mechanism (R-type TO CBE to EN 60934; M-type when fitted with optional manual release feature). Designed for plug-in mounting with E-T-A sockets 10 and 16.

## Typical applications

Extra low voltage wiring systems and components.

## Ordering information

<b>Type No.</b>	
2-5200	plug-in
<b>Manual release (optional)</b>	
H	manual release facility
<b>Current ratings</b>	
0.05...16 A	
2-5200 - H - 5 A ordering example	

Please be informed that we have minimum ordering quantities to be observed.

## Standard current ratings and typical internal resistance values

Current rating (A)	Internal resistance (Ω)	Current rating (A)	Internal resistance (Ω)
0.05	280	2.5	0.2
0.08	100	3	0.1
0.1	110	3,5	0.065
0.2	29	4	0.065
0.3	14	4.5	0.05
0.4	7	5	0.05
0.5	4.9	6	0.02
0.6	3.4	7	0.02
0.7	2.5	8	< 0.02
0.8	1.8	10	< 0.02
1	1.2	12	< 0.02
1.2	0.84	13	< 0.02
1.5	0.6	15	< 0.02
1.8	0.4	16	< 0.02
2	0.25		

## Approvals

Authority	Standard	Rated voltage	Current ratings
UL	UL 1077	AC 250 V DC 50 V	0.05 A...20 A 0.05 A...25 A
CSA	C22.2 No 235	AC 250 V DC 50 V	0.05 A...20 A 0.05 A...25 A
VDE	EN 60934	AC 250 V DC 28 V	0,05...16 A 0,05...16 A



2-5200-...

## Technical data

For further details please see: [www.e-t-a.de/ti\\_e](http://www.e-t-a.de/ti_e)

Voltage rating	DC 28 V (UL: AC 250; DC 50 V)	
Current rating range	0.05...16 A (up to 25 A to special order)	
Typical life	AC 250 V / DC 28 V: 0.05...16 A 5,000 operations at 2 x I <sub>N</sub> , inductive	
Ambient temperature	-20...+60 °C (-4...+140 °F)	
Insulation co-ordination (IEC 60664 and 60664 A)	rated impulse withstand voltage 2.5 kV	pollution degree 2
Dielectric strength (IEC 60664 and 60664A) operating area	test voltage AC 1,500 V	
Insulation resistance	> 100 MΩ (DC 500 V)	
Interrupting capacity I <sub>cn</sub>	0.05...2.5 A 3...5 A 6...16 A	8 x I <sub>N</sub> 20 x I <sub>N</sub> 400 A
Interrupting capacity (UL 1077)	U <sub>N</sub> AC 250 V DC 50 V	2,000 A 2,500 A
Degree of protection (IEC 60529/DIN 40050)	operating area IP40 terminal area IP00	
Vibration	8 g (57 to 500 Hz) ± 0.61 mm, (10-57 Hz), to IEC 60068-2-6, test Fc,	
Shock	25 g (11 ms) to IEC 60068-2-27, test Ea	
Corrosion	96 hours at 5 % salt mist, to IEC 60068-2-11, test Ka	
Humidity	240 hours at 95 % RH to IEC 60068-2-78, test Cab	
Mass	approx. 35 g	

All dimensions without tolerances are for reference only. In the interest of improved design, performance and cost effectiveness the right to make changes in these specifications without notice is reserved. Product markings may not be exactly as the ordering codes. Errors and omissions excepted.

## Dimensions

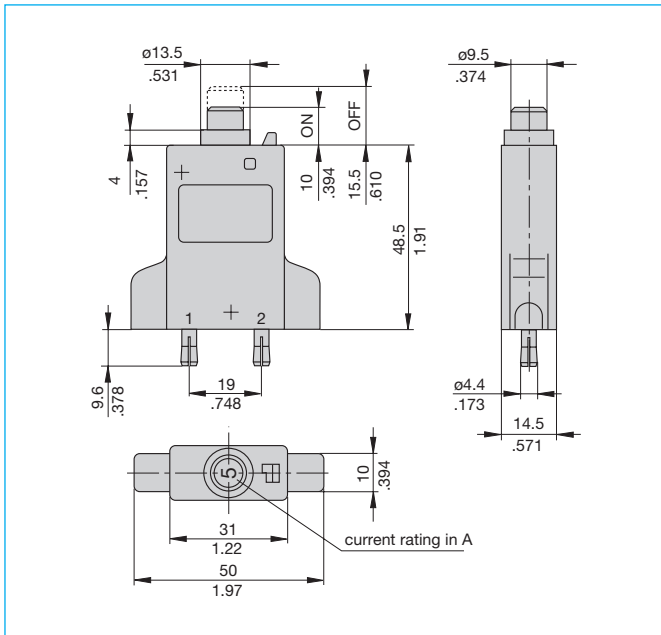

## Internal connection diagram

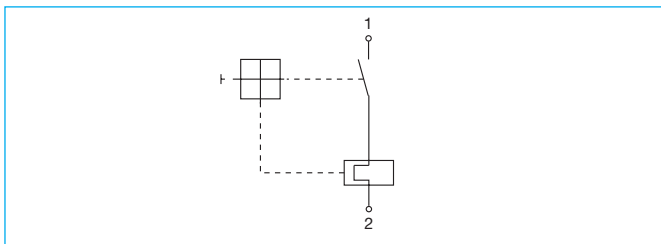

## Typical time/current characteristics at +23 °C/+73.4 °F

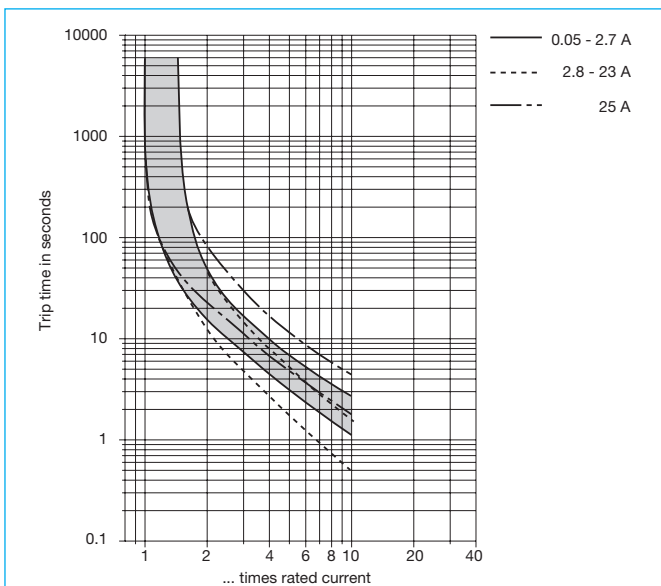

The time/current characteristic curve depends on the ambient temperature prevailing. In order to eliminate nuisance tripping, please multiply the circuit breaker current ratings by the derating factor shown below. See also section Technical information.

Ambient temperature °F	-4	+14	+32	+73.4	+104	+122	+140
°C	-20	-10	0	+23	+40	+50	+60
Derating factor	0.76	0.84	0.92	1	1.08	1.16	1.24

## Accessories

### Sockets 10R-K10

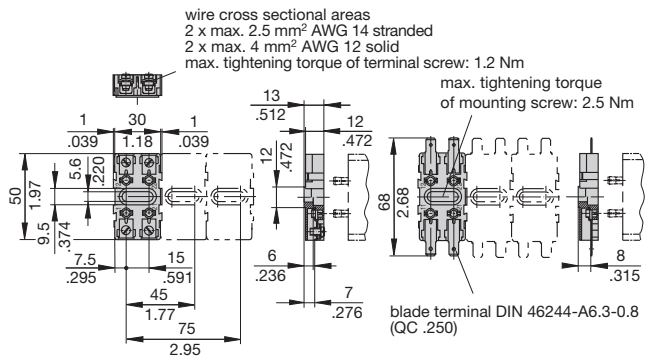

### 10R-P10

### 10R-A10

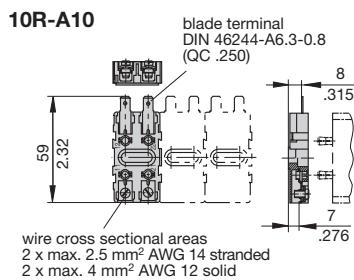

### Bus bar for sockets 10... Y 301 166 02 (2 way)

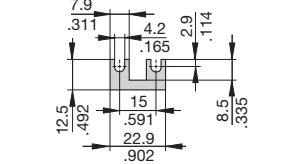

### Y 301 166 01 (4 way)

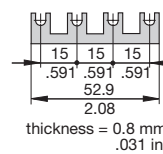

**Adapter for EN rail 50035-G32 (specified as a separate item)**  
**X 200 409 01**  
 for socket 16 available on request

### Blanking plug Y 301 477 01 for sockets 10R-P10/K10

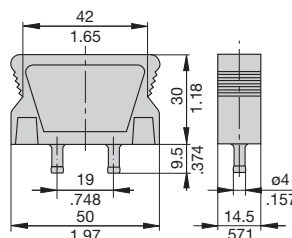

### Terminal for mounting rack X 200 800 01 for sockets 10R, 10F on EN rail 50 035-G32

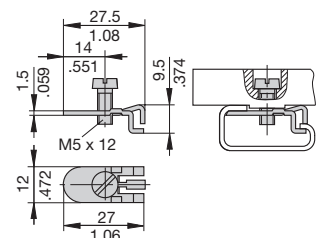

### Connector bus links -P10

- X 210 588 01/ 1.5 mm<sup>2</sup> (AWG 16) (brown)
- X 210 588 02/ 2.5 mm<sup>2</sup> (AWG 14) (black)
- X 210 588 03/ 2.5 mm<sup>2</sup> (AWG 14) (red)
- X 210 588 04/ 2.5 mm<sup>2</sup> (AWG 14) (blue)

### Connector bus links -K10

- X 210 589 01/ 2.5 mm<sup>2</sup> (AWG 14) (black)
- X 210 589 02/ 1.5 mm<sup>2</sup> (AWG 16) (brown)

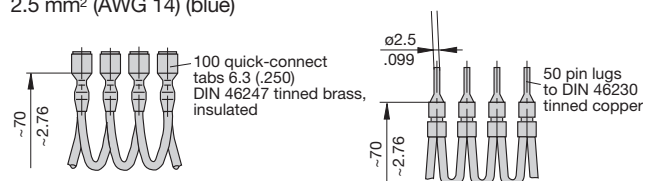

1.5 mm<sup>2</sup> - up to 13 A max. load  
 2.5 mm<sup>2</sup> - up to 20 A max. load

This is a metric design and millimeter dimensions take precedence (mm/inch)