

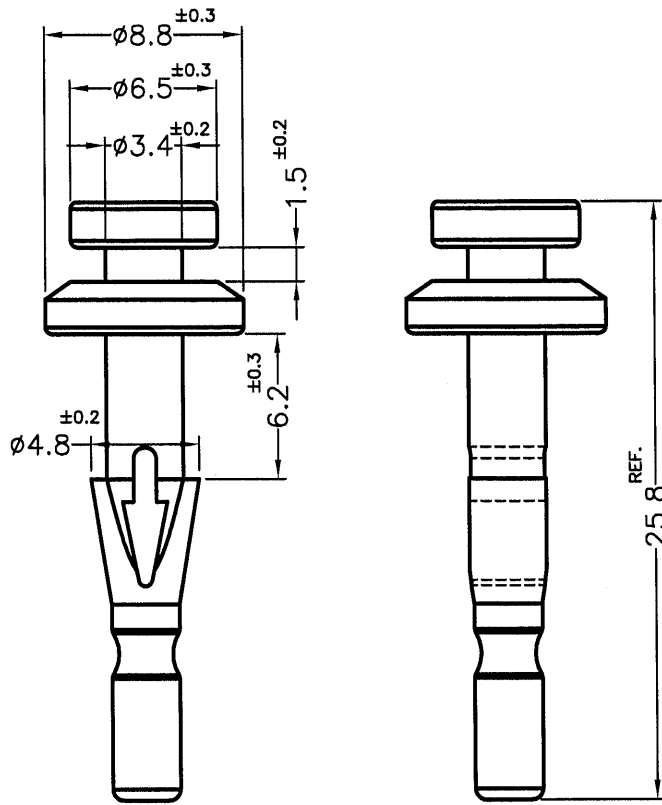



REVISIONS			
REV	DESCRIPTION	DATE	BY



PART NO.	MATERIAL	HARDNESS	COLOR
BUB-97G	TPE	45°±10°	BLACK
BUB-97H		55°±10°	
BUB-97V0	TPE UL94V-0	80°±10°	WHITE
BUB-97V0(W)		55°±10°	BLACK
BUB-97V01(B)		55°±10°	BLACK

NOTE: 1. SHRINKING IS NORMAL STATUS.
 內縮為正常現象。
 2. MADE OF EQUIVALENT MATERIAL.
 均可使用同等材質。

 康揚企業股份有限公司 KANG YANG HARDWARE ENTERPRISE CO., LTD. 康揚塑膠(東莞)有限公司 KANG YANG PLASTIC(DONG GUAN) CO., LTD. 康哲電腦配件(吳江)有限公司 KANG CHE COMPUTER COMPONENTS(WUJIANG) CO., LTD.		TITLE	FAN SNAP RIVET	SPEC. DWG			
		MATERIAL	SEE ABOVE	DATE	2009.12.28		
		HARDNESS	SEE ABOVE	DRAWN	SAI		
		COLOR	SEE ABOVE	CHECK			
PART NUMBER	SEE ABOVE	DRAWING NUMBER	BUB-97	UNLESS OTHERWISE SPECIFIED TOLERANCE	SEE ABOVE	APPROVED	
SIZE	A4	SCALE	3:1	UNIT	mm	REV	C