

Memory FRAM

256 K (32 K × 8) Bit

MB85R256F

■ DESCRIPTIONS

The MB85R256F is an FRAM (Ferroelectric Random Access Memory) chip in a configuration of 32,768 words × 8 bits, using the ferroelectric process and silicon gate CMOS process technologies for forming the nonvolatile memory cells.

The MB85R256F is able to retain data without using a back-up battery, as is needed for SRAM.

The memory cells used in the MB85R256F can be used for 10^{12} read/write operations, which is a significant improvement over the number of read and write operations supported by Flash memory and E²PROM.

The MB85R256F uses a pseudo - SRAM interface compatible with conventional asynchronous SRAM.

■ FEATURES

- Bit configuration : 32,768 words × 8 bits
- Read/write endurance : 10^{12} times / byte
- Data retention : 10 years (+ 85 °C), 95 years (+ 55 °C), over 200 years (+ 35 °C)
- Operating power supply voltage : 2.7 V to 3.6 V
- Low power consumption : Operating power supply current 5 mA (Typ)
Standby current 5 μA (Typ)
- Operation ambient temperature range: - 40 °C to + 85 °C
- Package : 28-pin plastic SOP (FPT-28P-M17)
28-pin plastic SOP (FPT-28P-M01)
: 28-pin plastic TSOP(1) (FPT-28P-M19)
Both are RoHS compliant

MB85R256F

■ PIN ASSIGNMENTS

(TOP VIEW)

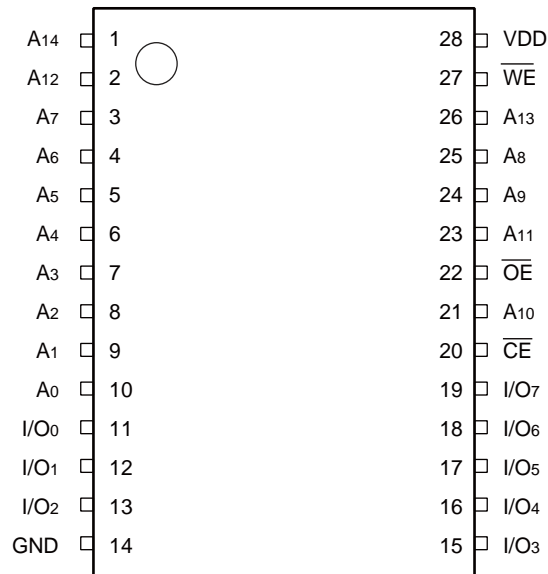

(FPT-28P-M17 / FPT-28P-M01)

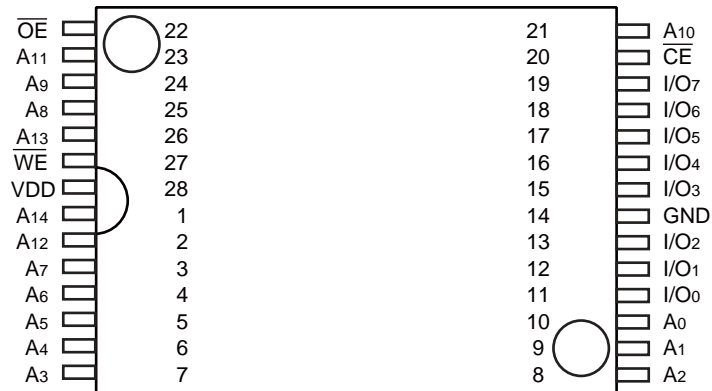

(FPT-28P-M19)

■ PIN FUNCTIONAL DESCRIPTIONS

Pin no.	Pin name	Functional description
1 to 10, 21, 23 to 26	A ₀ to A ₁₄	Address input pins
11 to 13, 15 to 19	I/O ₀ to I/O ₇	Data input/output pins
20	\overline{CE}	Chip enable input pin
27	\overline{WE}	Write Enable input pin
22	\overline{OE}	Output enable input pin
28	VDD	Supply Voltage pin
14	GND	Ground pin

MB85R256F

■ BLOCK DIAGRAM

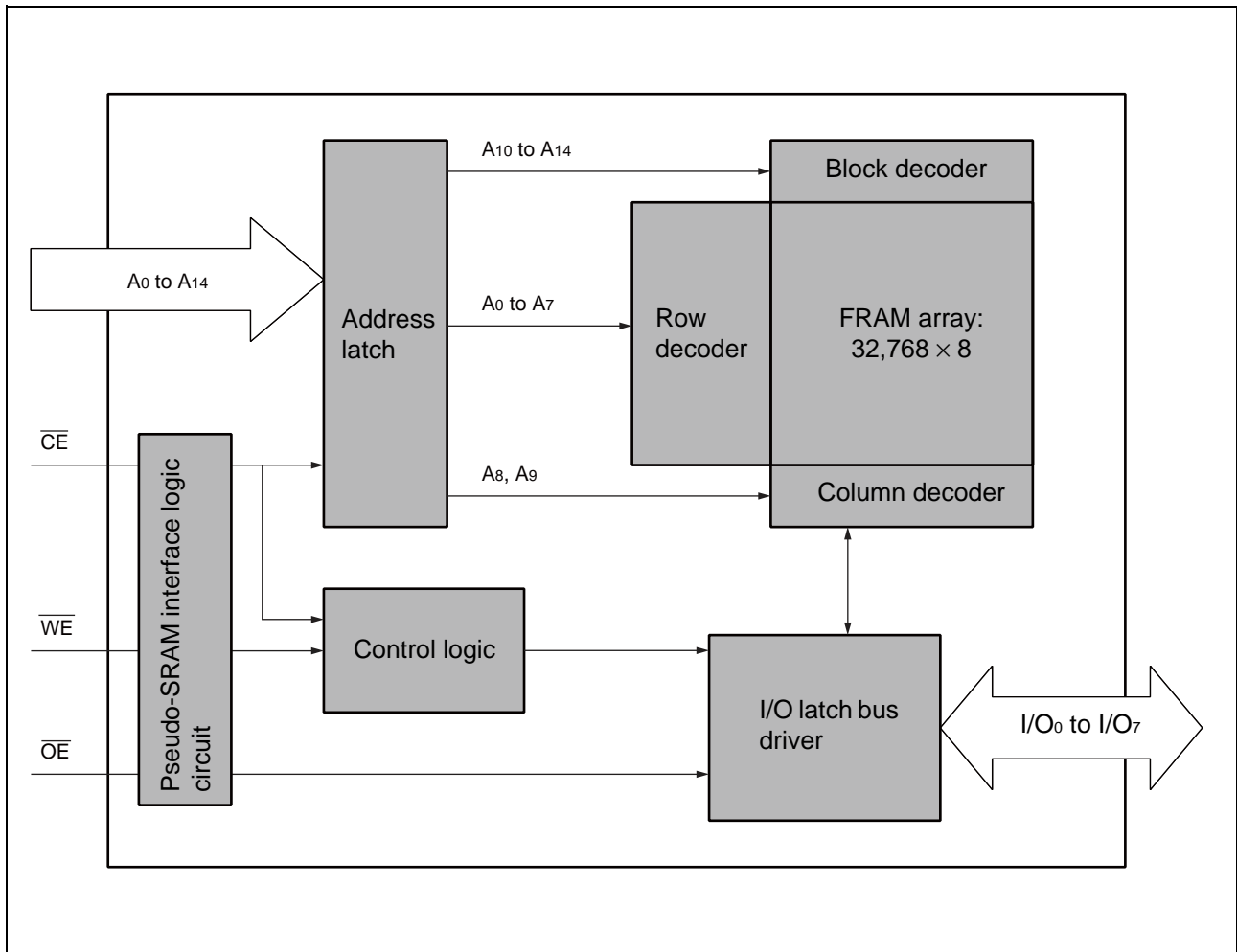

■ FUNCTION LIST

Operation mode	\overline{CE}	\overline{WE}	\overline{OE}	I/O ₀ to I/O ₇	Power supply current
Standby precharge	H	×	×	Hi-Z	Standby (I _{SB})
	×	L	L		
	×	H	H		
Latch address	L	$\overline{\text{L}}$	$\overline{\text{L}}$	—	—
	$\overline{\text{L}}$	H	L		
	$\overline{\text{L}}$	L	H		
Write	L	L	H	Data input	Operation (I _{DD})
Read	L	H	L	Data output	

H: High level, L: Low level, ×: can be either H, L, $\overline{\text{L}}$ or L , Hi-Z: High impedance, $\overline{\text{L}}$: Latch address at falling edge

■ ABSOLUTE MAXIMUM RANGES

Parameter	Symbol	Rating		Unit
		Min	Max	
Power supply voltage*	V_{DD}	- 0.5	+ 4.0	V
Input voltage*	V_{IN}	- 0.5	$V_{DD} + 0.5$	V
Output voltage*	V_{OUT}	- 0.5	$V_{DD} + 0.5$	V
Operation ambient temperature	T_A	- 40	+ 85	°C
Storage temperature	T_{stg}	- 55	+ 125	°C

* : These parameters are based on the condition that V_{SS} is 0 V.

WARNING: Semiconductor devices can be permanently damaged by application of stress (voltage, current, temperature, etc.) in excess of absolute maximum ratings. Do not exceed these ratings.

■ RECOMMENDED OPERATING CONDITIONS

Parameter	Symbol	Value			Unit
		Min	Typ	Max	
Power supply voltage*	V_{DD}	2.7	3.3	3.6	V
High level input voltage*	V_{IH}	$V_{DD} \times 0.8$	—	$V_{DD} + 0.5$	V
Low level input voltage*	V_{IL}	- 0.5	—	+ 0.6	V
Operation ambient temperature	T_A	- 40	—	+ 85	°C

* : These parameters are based on the condition that V_{SS} is 0 V.

WARNING: The recommended operating conditions are required in order to ensure the normal operation of the semiconductor device. All of the device's electrical characteristics are warranted when the device is operated within these ranges.

Always use semiconductor devices within their recommended operating condition ranges. Operation outside these ranges may adversely affect reliability and could result in device failure.

No warranty is made with respect to uses, operating conditions, or combinations not represented on the data sheet. Users considering application outside the listed conditions are advised to contact their representatives beforehand.

MB85R256F

■ ELECTRICAL CHARACTERISTICS

1. DC Characteristics

(within recommended operating conditions)

Parameter	Symbol	Conditions	Value			Unit
			Min	Typ	Max	
Input leakage current	$ I_{LI} $	$V_{IN} = 0\text{ V to }V_{DD}$	—	—	10	μA
Output leakage current	$ I_{LO} $	$V_{OUT} = 0\text{ V to }V_{DD}$, $\overline{CE} = V_{IH}$ or $\overline{OE} = V_{IH}$	—	—	10	μA
Operating power supply current*1	I_{DD}	$\overline{CE} = 0.2\text{ V}$, Other inputs = $V_{DD} - 0.2\text{ V}/0.2\text{ V}$, $t_{RC}(\text{Min})$, $I_{out} = 0\text{ mA}$	—	5	10	mA
Standby current*2	I_{SB}	$\overline{CE}, \overline{WE}, \overline{OE} \geq V_{DD}$	—	5	50	μA
High level output voltage	V_{OH}	$I_{OH} = -2.0\text{ mA}$	$V_{DD} \times 0.8$	—	—	V
Low level output voltage	V_{OL}	$I_{OL} = 2.0\text{ mA}$	—	—	0.4	V

*1: During the measurement of I_{DD} , the Address and Data In were taken to only change once per active cycle.
I_{out}: output current

*2: All pins other than setting pins shall be input at the CMOS level voltages such as $H \geq V_{DD}$, $L \leq 0\text{ V}$.

2. AC Characteristics

• AC Characteristics Test Condition

Power supply voltage : 2.7 V to 3.6 V

Operation ambient temperature: -40 °C to +85 °C

Input voltage amplitude : 0.3 V to 2.7 V

Input rising time : 10 ns

Input falling time : 10 ns

Input evaluation level : $V_{DD}/2$

Output evaluation level : $V_{DD}/2$

Output Load Capacitance: 100 pF

(1) Read cycle

Parameter	Symbol	Value		Unit
		Min	Max	
Read cycle time	t_{RC}	150	—	ns
\overline{CE} active time	t_{CA}	70	500	
Read pulse width	t_{RP}	70	500	
Precharge time	t_{PC}	80	—	
Address setup time	t_{AS}	0	—	
Address hold time	t_{AH}	25	—	
\overline{CE} access time	t_{CE}	—	70	
\overline{OE} access time	t_{OE}	—	70	
\overline{CE} output floating time	t_{HZ}	—	25	
\overline{OE} output floating time	t_{OHZ}	—	25	

(2) Write cycle

Parameter	Symbol	Value		Unit
		Min	Max	
Write cycle time	t_{WC}	150	—	ns
\overline{CE} active time	t_{CA}	70	500	
Write pulse width	t_{WP}	70	500	
Precharge time	t_{PC}	80	—	
Address setup time	t_{AS}	0	—	
Address hold time	t_{AH}	25	—	
Data setup time	t_{DS}	50	—	
Data hold time	t_{DH}	0	—	

3. Pin Capacitance

Parameter	Symbol	Conditions	Value			Unit
			Min	Typ	Max	
Input capacitance	C_{IN}	$V_{DD} = V_{IN} = V_{OUT} = 0\text{ V}$, $f = 1\text{ MHz}$, $T_A = +25\text{ }^\circ\text{C}$	—	—	10	pF
Output capacitance	C_{OUT}		—	—	10	pF

MB85R256F

■ TIMING DIAGRAM

1. Read cycle (\overline{CE} Control)

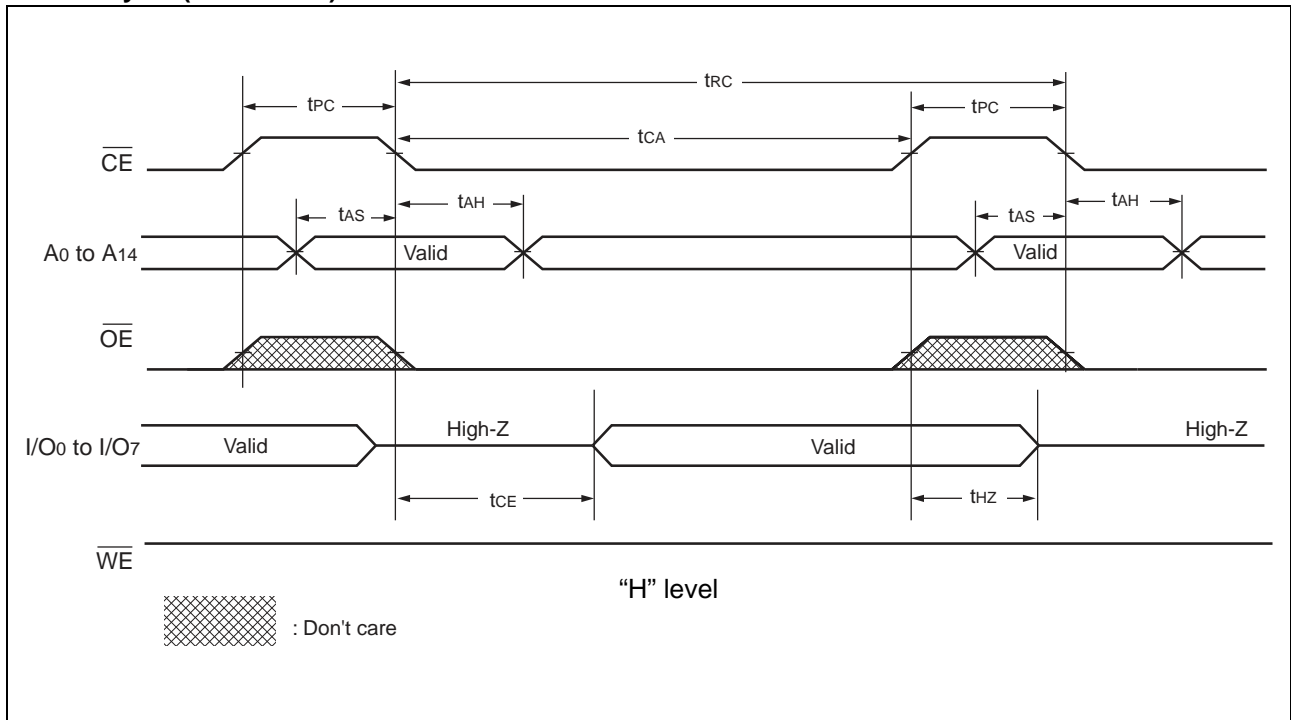

2. Read cycle (\overline{OE} Control)

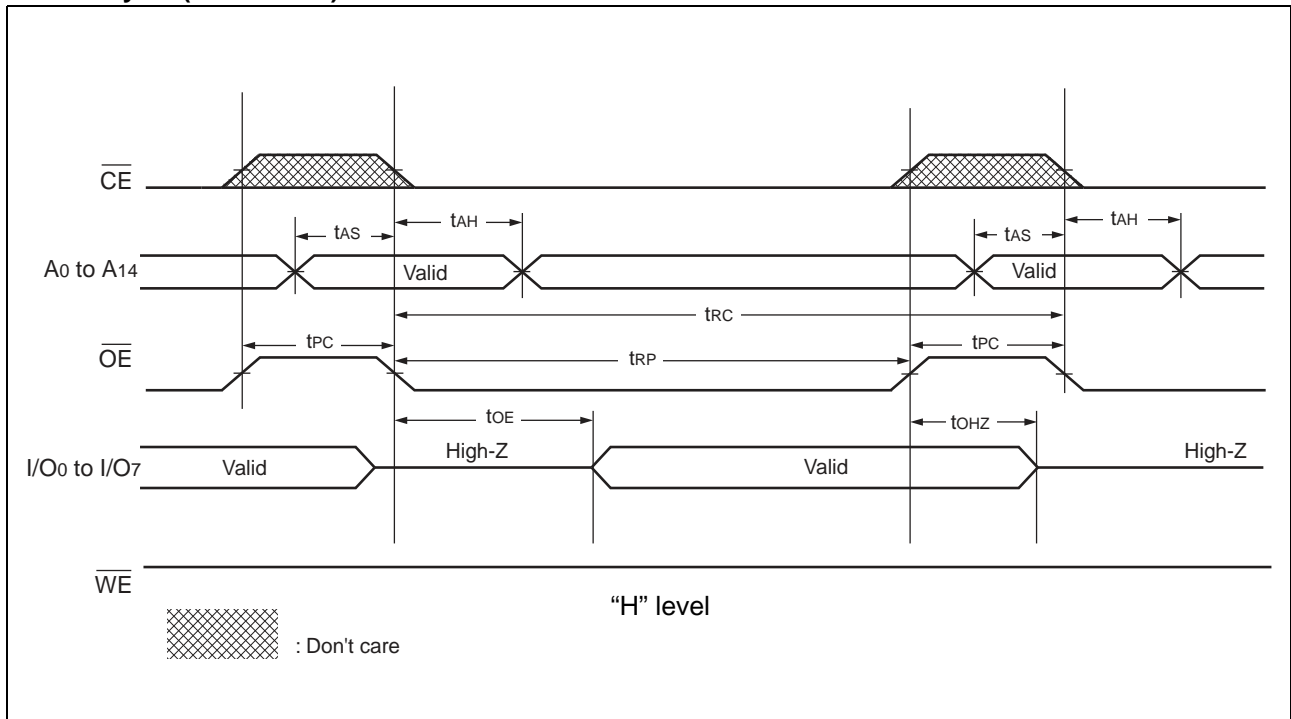

3. Write cycle ($\overline{\text{CE}}$ Control)

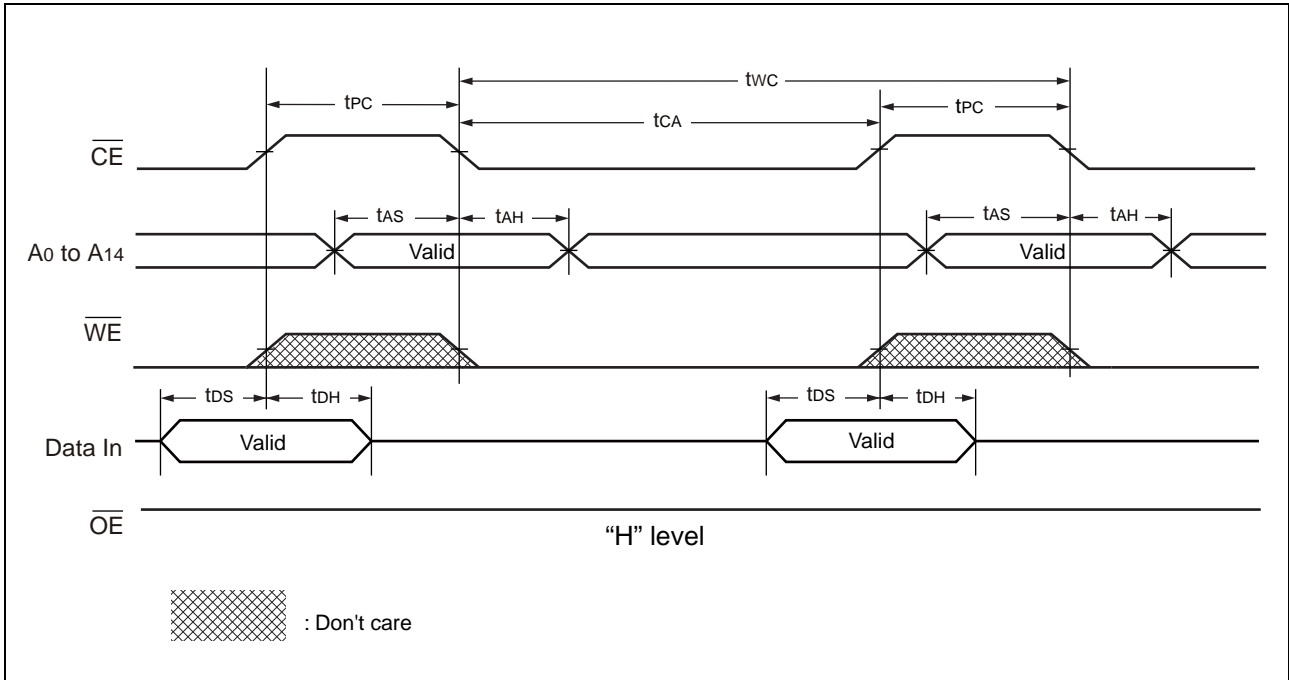

4. Write cycle ($\overline{\text{WE}}$ Control)

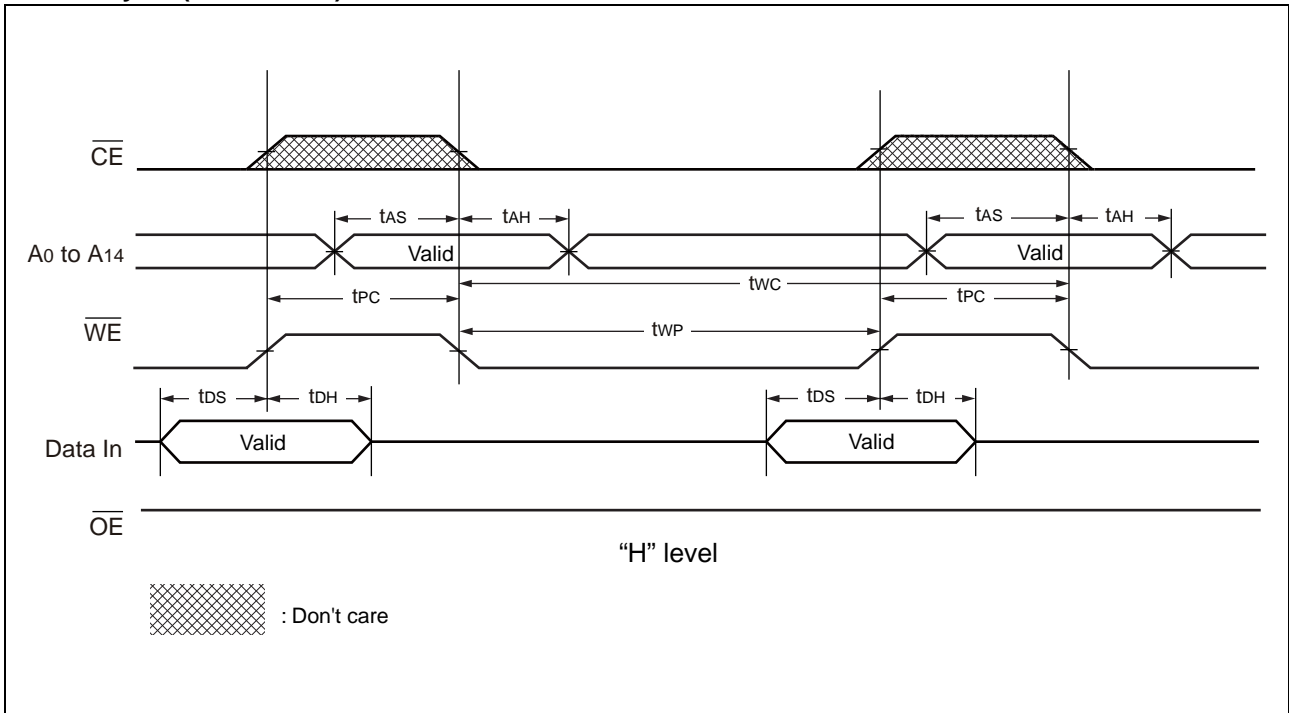

MB85R256F

POWER ON/OFF SEQUENCE

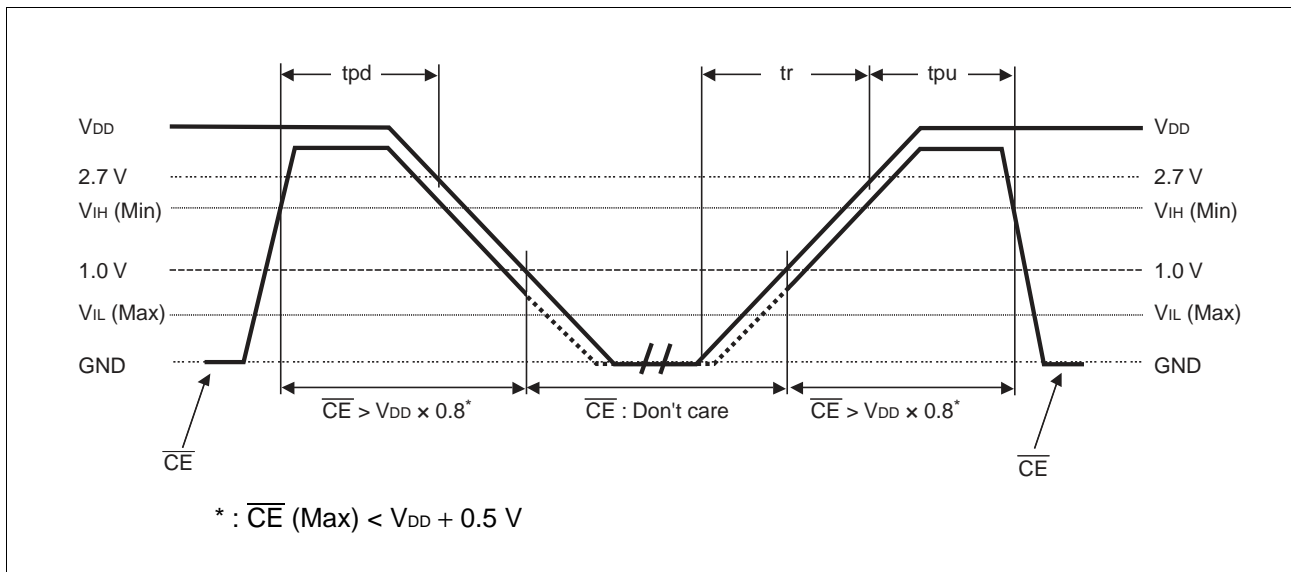

Parameter	Symbol	Value			Unit
		Min	Typ	Max	
\overline{CE} level hold time at power OFF	tpd	80	—	—	ns
\overline{CE} level hold time at power ON	tpu	80	—	—	ns
Power supply rising time	tr	0.05	—	200	ms

If the device does not operate within the specified conditions of read cycle, write cycle or power on/off sequence, memory data can not be guaranteed.

FRAM CHARACTERISTICS

Item	Min	Max	Unit	Parameter
Read/Write Endurance*1	10 ¹²	—	Times/byte	Operation Ambient Temperature T _A = + 85 °C
Data Retention*2	10	—	Years	Operation Ambient Temperature T _A = + 85 °C
	95	—		Operation Ambient Temperature T _A = + 55 °C
	≥ 200	—		Operation Ambient Temperature T _A = + 35 °C

*1 : Total number of reading and writing defines the minimum value of endurance, as an FRAM memory operates with destructive readout mechanism.

*2 : Minimum values define retention time of the first reading/writing data right after shipment, and these values are calculated by qualification results.

NOTES ON USE

After the IR reflow completed, it is not guaranteed to save the data written prior to the IR reflow.

■ ESD AND LATCH-UP

Test	DUT	Value
ESD HBM (Human Body Model) JESD22-A114 compliant	MB85R256FPF-G-BNDE1 MB85R256FPFCN-G-BNDE1	$\geq 2000 \text{ V} $
ESD MM (Machine Model) JESD22-A115 compliant		$\geq 200 \text{ V} $
ESD CDM (Charged Device Model) JESD22-C101 compliant		$\geq 1000 \text{ V} $
Latch-Up (I-test) JESD78 compliant		—
Latch-Up (V_{supply} overvoltage test) JESD78 compliant		—
Latch-Up (Current Method) Proprietary method		$\geq 300 \text{ mA} $
Latch-Up (C-V Method) Proprietary method		—

- Current method of Latch-Up Resistance Test

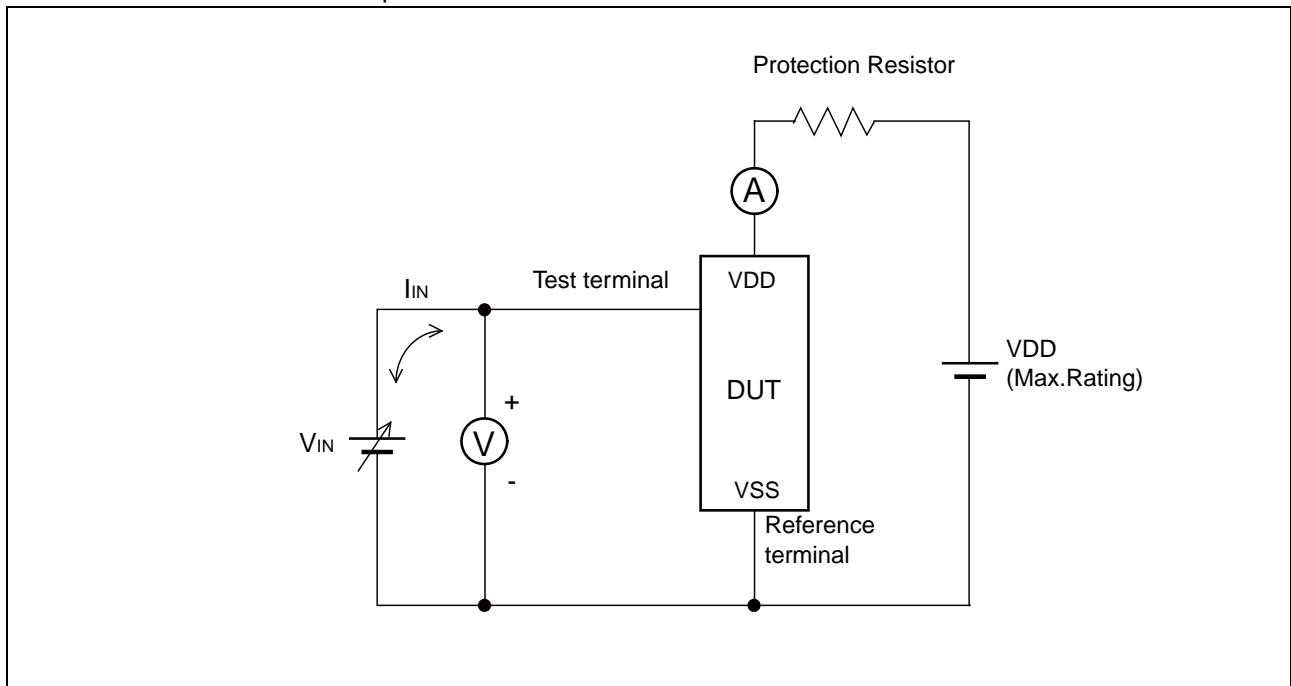

Note : The voltage V_{IN} is increased gradually and the current I_{IN} of 300 mA at maximum shall flow.
 Confirm the latch up does not occur under $I_{\text{IN}} = \pm 300 \text{ mA}$.
 In case the specific requirement is specified for I/O and I_{IN} cannot be 300 mA, the voltage shall be increased to the level that meets the specific requirement.

MB85R256F

- C-V method of Latch-Up Resistance Test

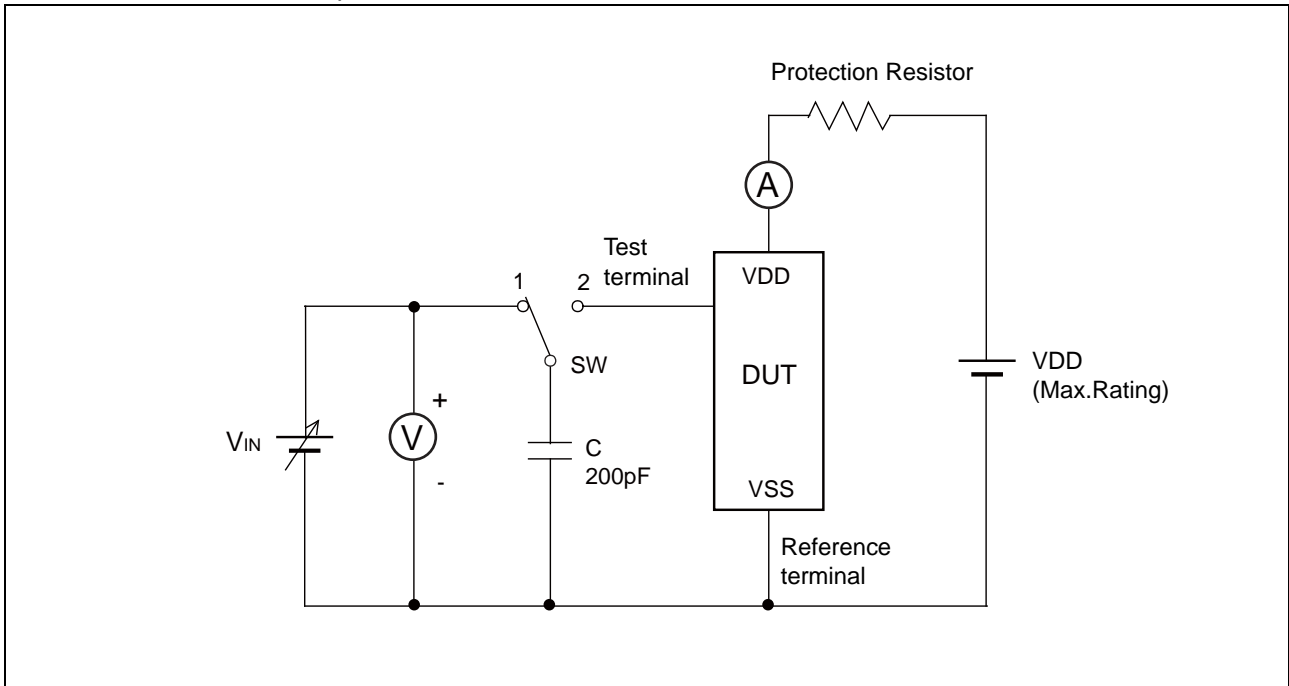

Note : Charge voltage alternately switching 1 and 2 approximately 2 sec interval. This switching process is considered as one cycle.
Repeat this process 5 times. However, if the latch-up condition occurs before completing 5 times, this test must be stopped immediately.

REFLOW CONDITIONS AND FLOOR LIFE

Item	Condition	
Method	IR (infrared reflow) , Convection	
Times	2	
Floor life	Before unpacking	Please use within 2 years after production.
	From unpacking to 2nd reflow	Within 8 days
	In case over period of floor life	Baking with 125 °C+/-3 °C for 24hrs+2hrs-0hrs is required. Then please use within 8 days. (Please remember baking is up to 2 times)
Floor life condition	Between 5 °C and 30 °C and also below 70%RH required. (It is preferred lower humidity in the required temp range.)	

Reflow Profile

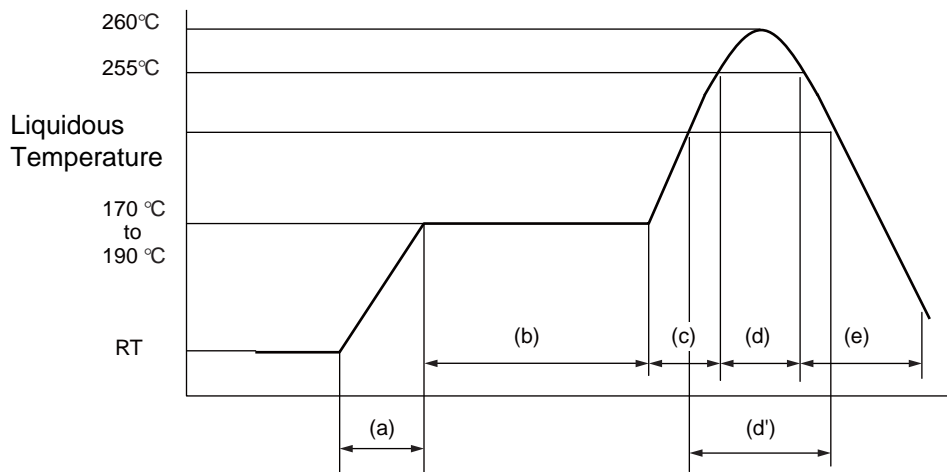

- (a) Average ramp-up rate : 1 °C/s to 4 °C/s
- (b) Preheat & Soak : 170 °C to 190 °C, 60 s to 180 s
- (c) Average ramp-up rate : 1 °C/s to 4 °C/s
- (d) Peak temperature : Temperature 260 °C Max; 255 °C within 10 s
- (d') Liquidous temperature : Up to 230 °C within 40 s or
Up to 225 °C within 60 s or
Up to 220 °C within 80 s
- (e) Cooling : Natural cooling or forced cooling

Note : Temperature on the top of the package body is measured.

■ RESTRICTED SUBSTANCES

This product complies with the regulations below (Based on current knowledge as of November 2011).

- EU RoHS Directive (2002/95/EC)
- China RoHS (Administration on the Control of Pollution Caused by Electronic Information Products
(电子信息产品污染控制管理办法))
- Vietnam RoHS (30/2011/TT-BCT)

Restricted substances in each regulation are as follows.

Substances	Threshold	Contain status*
Lead and its compounds	1,000 ppm	○
Mercury and its compounds	1,000 ppm	○
Cadmium and its compounds	100 ppm	○
Hexavalent chromium compound	1,000 ppm	○
Polybrominated biphenyls (PBB)	1,000 ppm	○
Polybrominated diphenyl ethers (PBDE)	1,000 ppm	○

* : The mark of "○" shows below a threshold value.

■ ORDERING INFORMATION

Part number	Package	Shipping form	Minimum shipping quantity
MB85R256FPF-G-BNDE1	28-pin plastic SOP (FPT-28P-M17)	Tube	1
MB85R256FPFCN-G-BNDE1	28-pin plastic TSOP(1) (FPT-28P-M19)	Tray	1
MB85R256FPF-G-BND-ERE1	28-pin plastic SOP (FPT-28P-M17)	Embossed carrier tape	1000
MB85R256FPNF-G-JNE2	28-pin plastic SOP (FPT-28P-M01)	Tube	1
MB85R256FPNF-G-JNERE2	28-pin plastic SOP (FPT-28P-M01)	Embossed carrier tape	1000

MB85R256F

PACKAGE DIMENSIONS

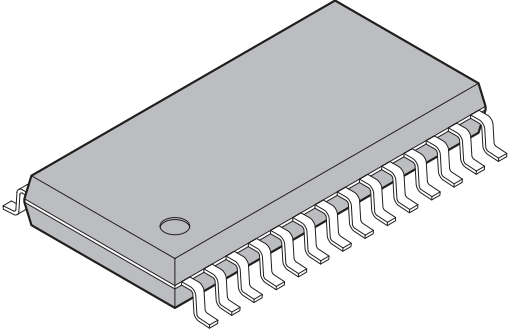
<p>28-pin plastic SOP</p>  <p>(FPT-28P-M17)</p>	Lead pitch	1.27 mm
	Package width × package length	8.6 × 17.75 mm
	Lead shape	Gullwing
	Sealing method	Plastic mold
	Mounting height	2.80 mm MAX
	Weight	0.82 g
	Code (Reference)	P-SOP28-8.6×17.75-1.27

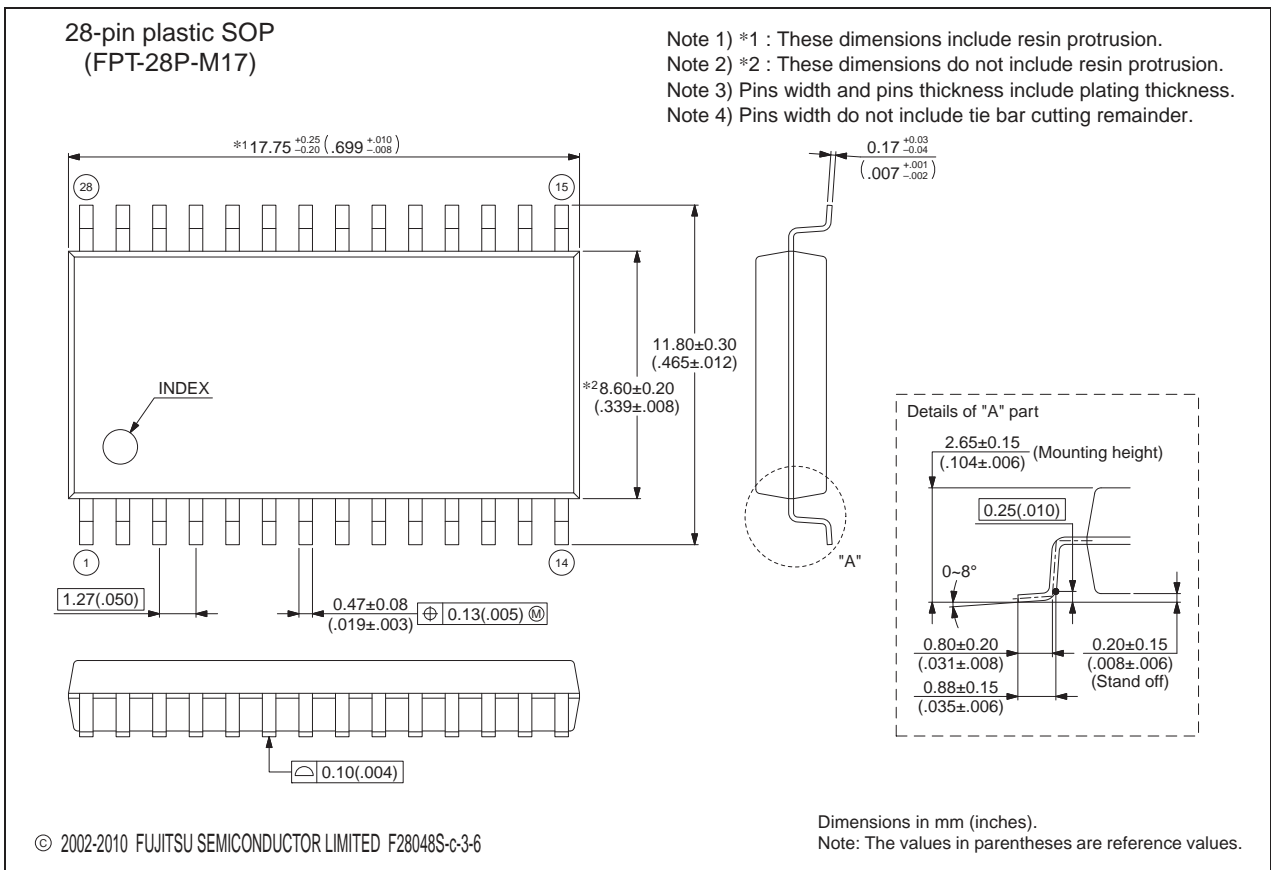

(Continued)

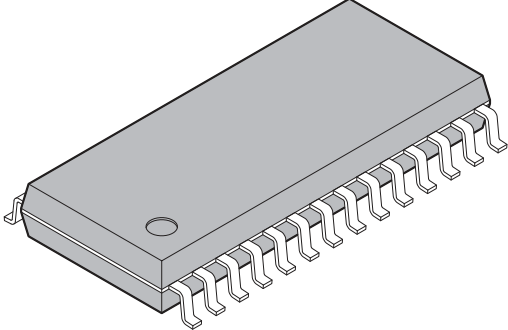
<p>28-pin plastic SOP</p>  <p>(FPT-28P-M01)</p>	Lead pitch	1.27 mm
	Package width × package length	7.6 × 17.75 mm
	Lead shape	Gullwing
	Sealing method	Plastic mold
	Mounting height	2.80 mm MAX
	Weight	0.67 g
	Code (Reference)	P-SOP28-7.6×17.75-1.27

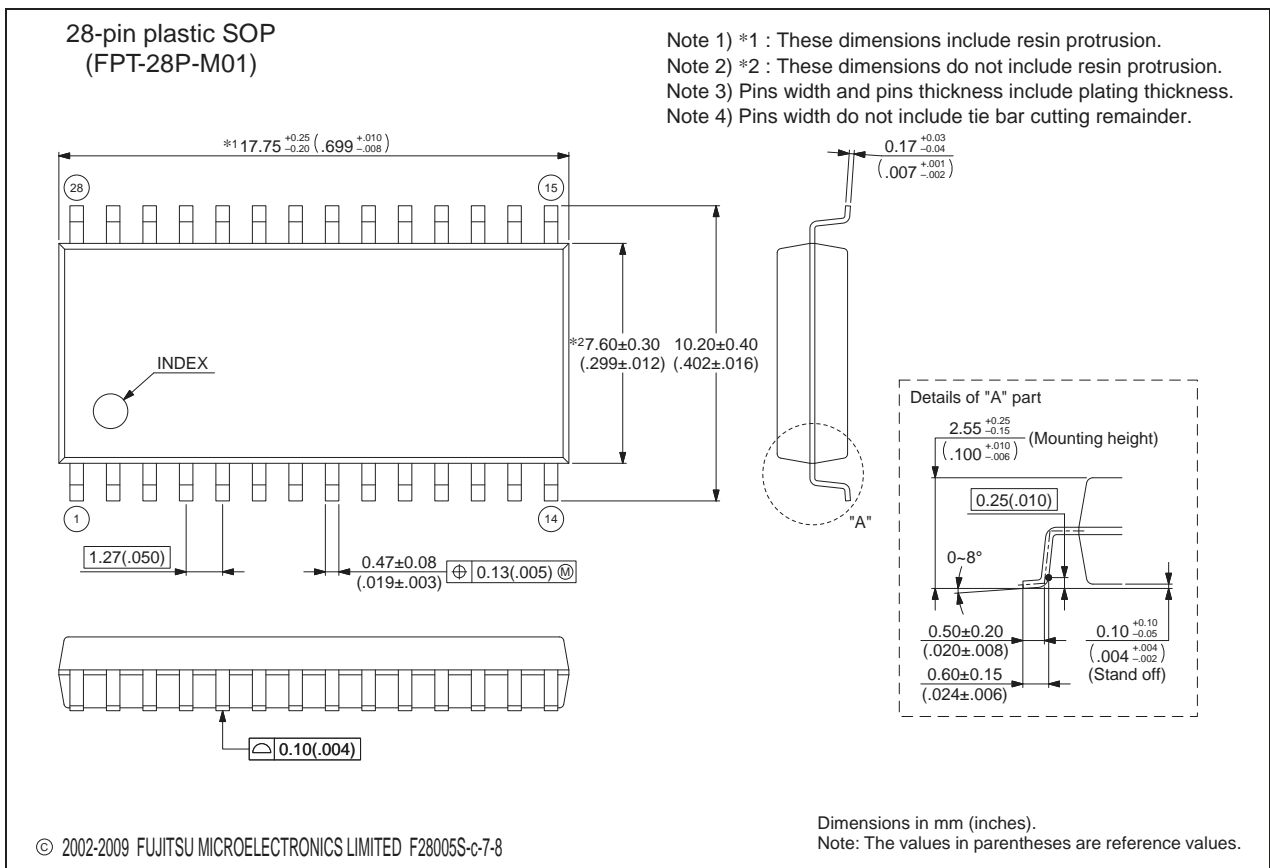

(Continued)

MB85R256F

(Continued)

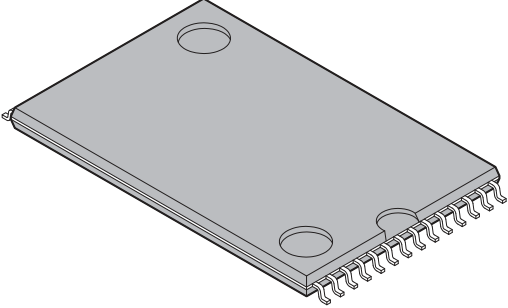
<p>28-pin plastic TSOP (1)</p>  <p>(FPT-28P-M19)</p>	Lead pitch	0.55 mm
	Package width · package length	11.80 · 8.00 mm
	Lead shape	Gullwing
	Sealing method	Plastic mold
	Mounting height	1.20 mm Max
	Weight	Approx. 0.25 g
	Code (Reference)	P-TSOP(1)28-11.8· 8-0.55

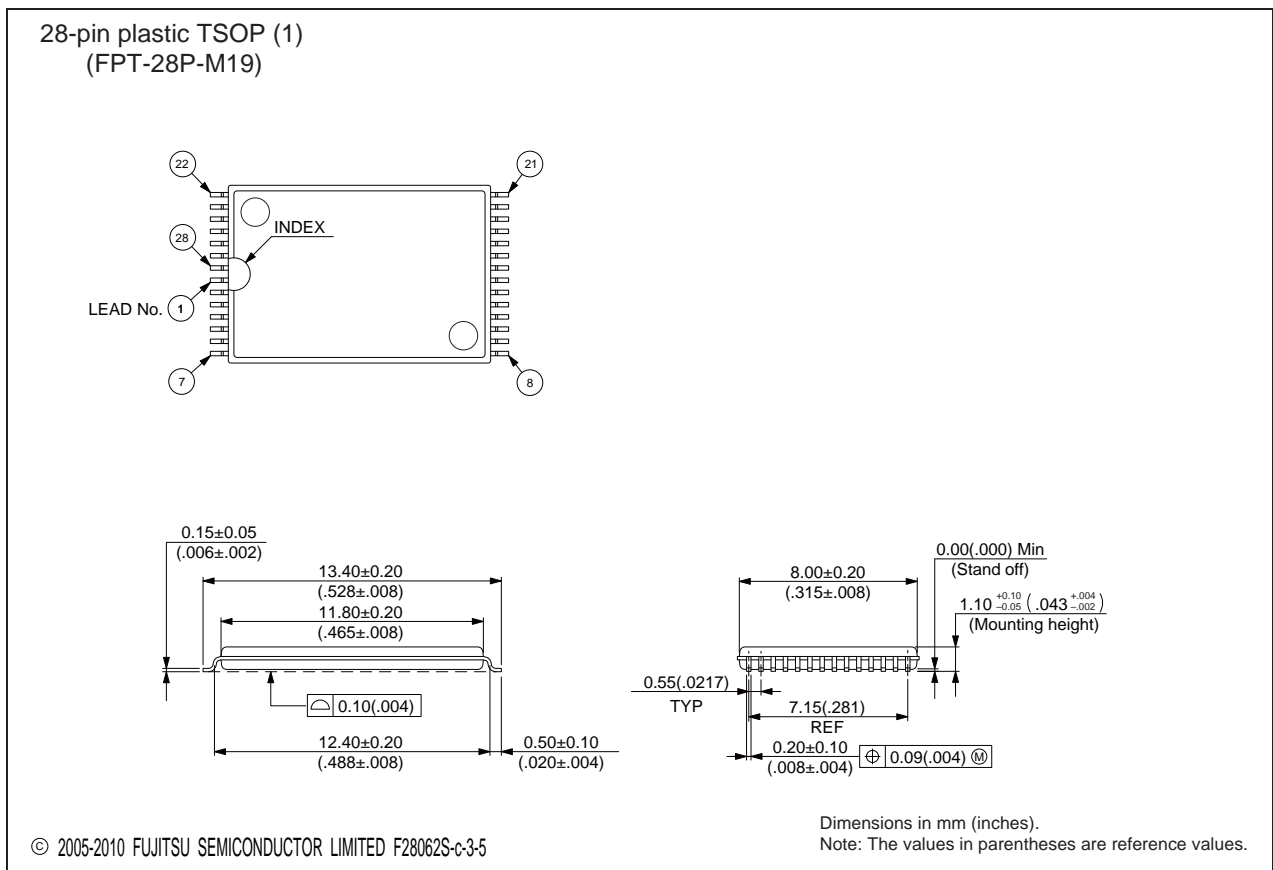

■ MARKING

[MB85R256FPF-G-BNDE1]
[MB85R256FPF-G-BND-ERE1]

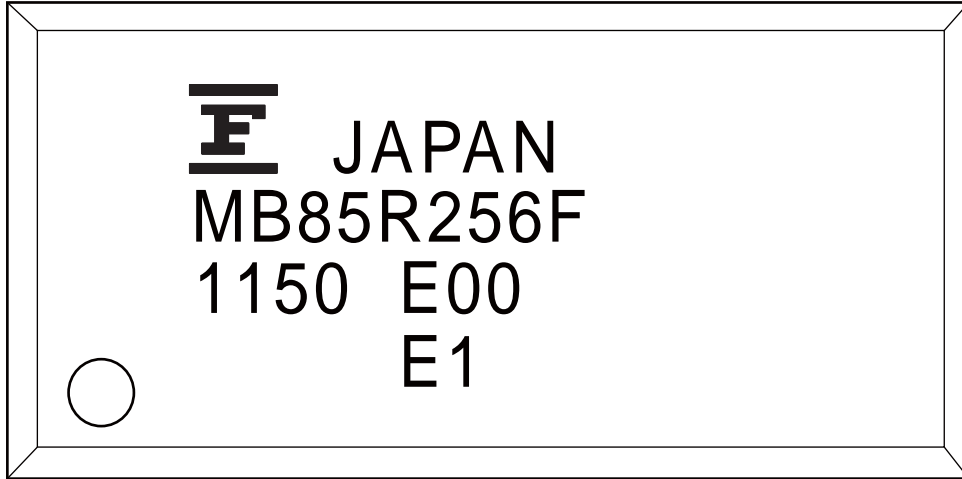

[FPT-28P-M17]

[MB85R256FPNF-G-JNE2]
[MB85R256FPNF-G-JNERE2]



[FPT-28P-M01]

[MB85R256FPFCN-G-BNDE1]

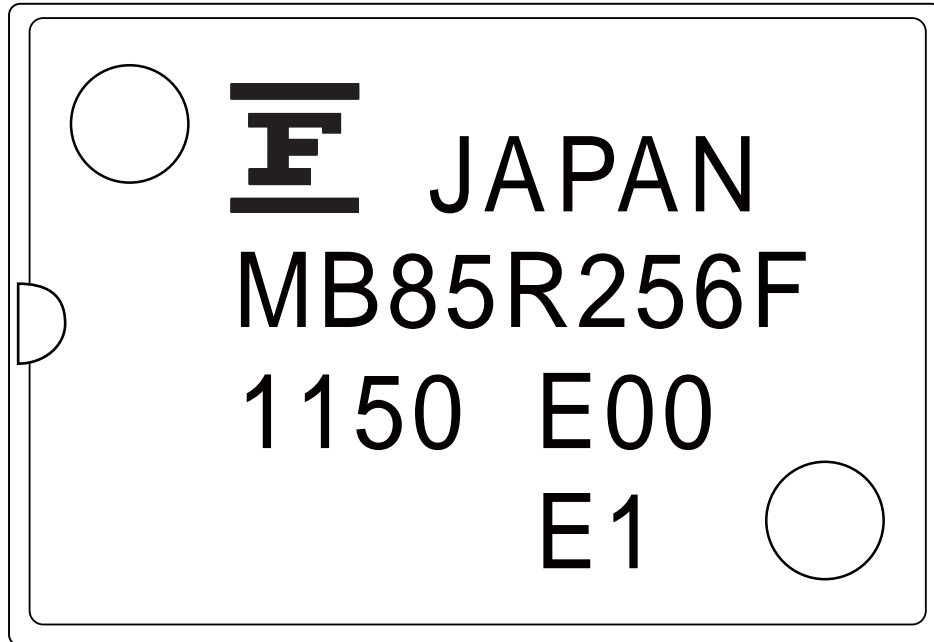

[FPT-28P-M19]

■ PACKING INFORMATION

1. Tube

1.1 Tube Dimensions

- Tube/stopper shape

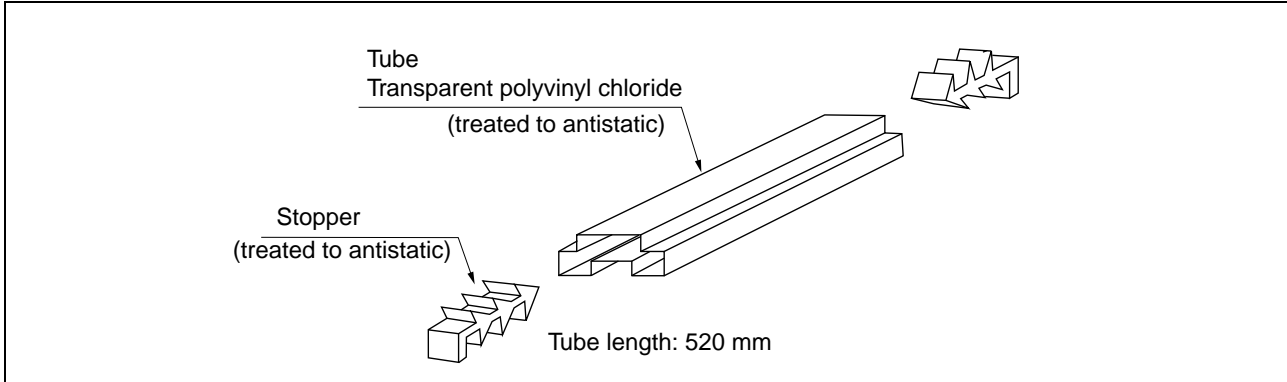

Tube cross-sections and Maximum quantity

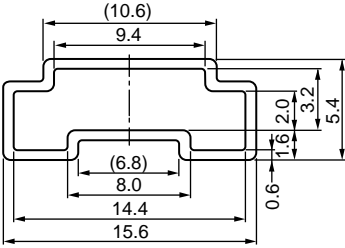

Package form	Package code	Maximum quantity		
		pcs/tube	pcs/inner box	pcs/outer box
SOP, 28, plastic  ©2002-2010 FUJITSU SEMICONDUCTOR LIMITED F28011-SET1:FJ99L-0018-E0010-1-K-3 $t = 0.6$ Transparent polyvinyl chloride	FPT-28P-M17	28	2240	8960

(Dimensions in mm)

MB85R256F

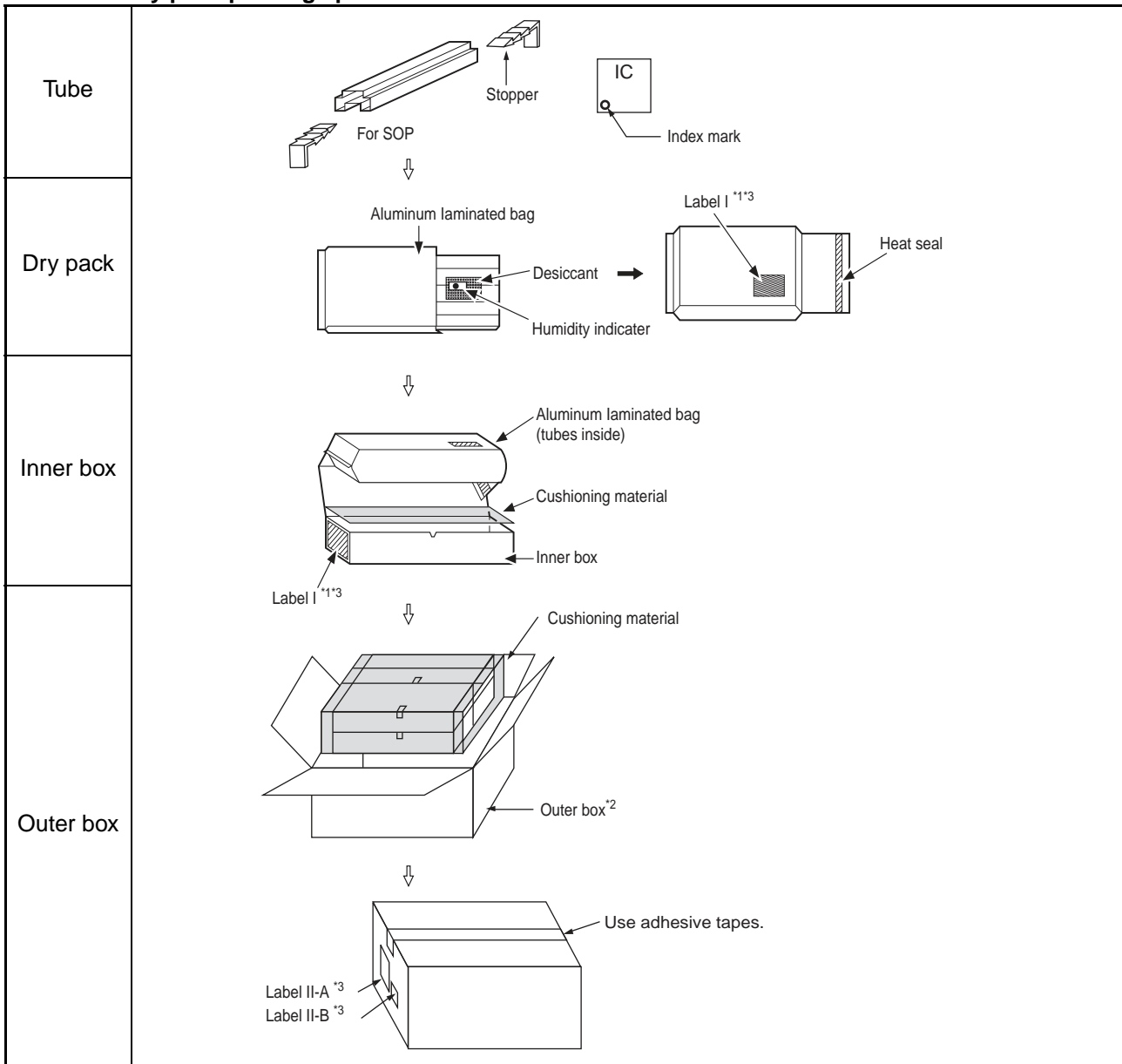
1.2 TUBE Dry pack packing specifications



*1: For a product of which part number is suffixed with "E1", a "   " marks is display to the moisture barrier bag and the inner boxes.

*2: The space in the outer box will be filled with empty inner boxes, or cushions, etc.

*3: Please refer to an attached sheet about the indication label.

Note: The packing specifications may not be applied when the product is delivered via a distributor.

1.3 Product label indicators

Label I: Label on Inner box/Moisture Barrier Bag/ (It sticks it on the reel for the emboss taping)
 [C-3 Label (50mm × 100mm) Supplemental Label (20mm × 100mm)]

XXXXXXXXXXXXXXXX (Customer part number or FJ part number)	← C-3 Label
(3N)1 XXXXXXXXXXXXXXXX XXX (LEAD FREE mark) (Part number and quantity)	
XXXXXXXXXXXXXXXXXXXXX QC PASS	
(3N)2 XXXXXXXXXXXXXXXX XXXXXXXX (FJ control number)	
XXXXXXXXXXXXXXXXXXXXX XXX pcs (Quantity)	
XXXXXXXXXXXXXXXXXXXXX (Customer part number or FJ part number)	
XXXXXXXXXXXXXXXXXXXXX (Customer part number or FJ part number bar code)	
XXXX/XX/XX (Packed years/month/day) ASSEMBLED IN xxxx	← Perforated line
XXXXXXXXXXXXXXXXXXXXX (Customer part number or FJ part number)	← Supplemental Label
(FJ control number bar code)	
XXXXXXXX (Package count) XXXX-XXX XXX	
XXXXXXXXXXXX (FJ control number) (Lot Number and quantity)	
XXXXXXXXXXXXXXXXXXXXX (Comment)	

Label II-A: Label on Outer box [D Label] (100mm × 100mm)

← D Label	
発注者 XXXXXXXXXXXXXXXX (Customer Name) (CUST.)	受注者 (VENDOR) 富士通
受渡場所名 XXXXXXXXXXXX (Delivery Address) (DELIVERY POINT)	セミコンダクター株式会社
納品キー番号 XXXXXXXXXXXXXXXX (TRANS.NO.) (FJ control number)	XXX (FJ control number)
品名コード XXXXXXXXXXXXXXXX (PART NO.) (Customer part number or FJ part number)	XXX (FJ control number)
	XXXXXXXXXXXXXXXXXXXXX (Part number)
品名 (PART NAME) XXXXXXXXXXXXXXXX (Part number)	
入数/納入数量 XXX/XXX (Q'TY/TOTAL Q'TY)	単位 XX (UNIT)
発注者用備考 (CUSTOMER'S REMARKS) XXXXXXXXXXXXXXXXXXXXX	梱包個数 (PACKAGE COUNT) XXX/XXX
(3N)3 XXXXXXXXXXXXXXXX XXX (FJ control number + Product quantity)	
XXXXXXXXXXXXXXXXXXXXX (FJ control number + Product quantity bar code)	
(3N)4 XXXXXXXXXXXXXXXX XXX (Part number + Product quantity)	
XXXXXXXXXXXXXXXXXXXXX (Part number + Product quantity bar code)	
(3N)5 XXXXXXXXXXXXXXXX (FJ control number)	
XXXXXXXXXXXXXXXXXXXXX (FJ control number bar code)	

Label II-B: Outer boxes product indicate

XXXXXXXXXXXXXXXXXXXXX (Part number)		
(Lot Number)	(Count)	(Quantity)
XXXX-XXX	X 箱	XXX 個
XXXX-XXX	X 箱	XXX 個
	計	XXX 個

Note: Depending on shipment state, "Label II-A" and "Label II-B" on the external boxes might not be printed.

MB85R256F

1.4 Dimensions for Containers

(1) Dimensions for inner box

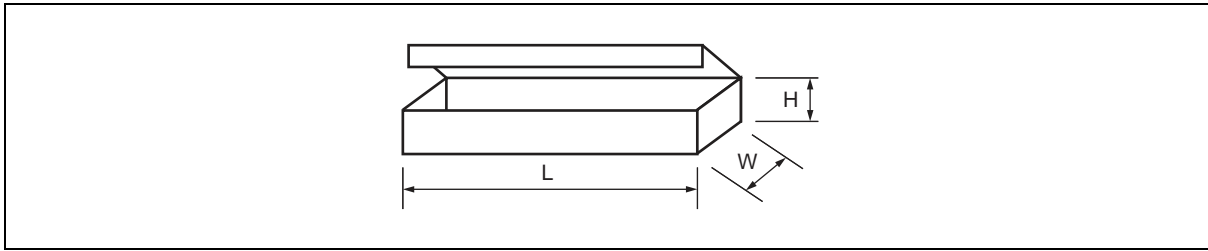

L	W	H
540	125	75

(Dimensions in mm)

(2) Dimensions for outer box

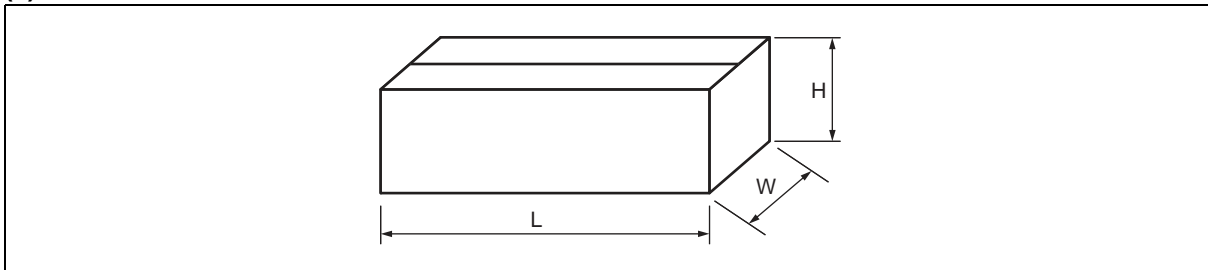

L	W	H
565	270	180

(Dimensions in mm)

2. Tray

2.1 Tray Dimensions

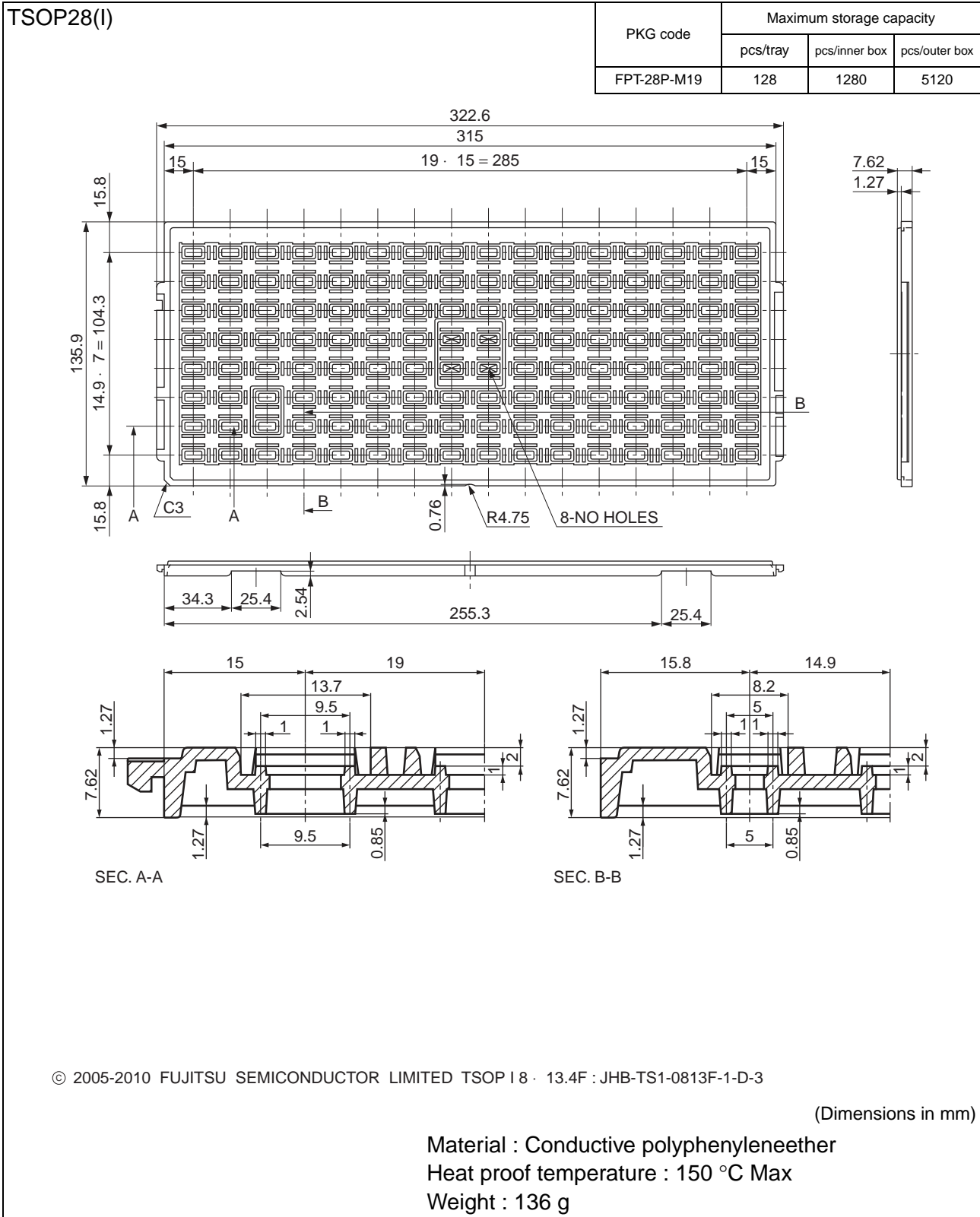

MB85R256F

2.2 IEC (JEDEC) TRAY Dry Pack Packing Specifications

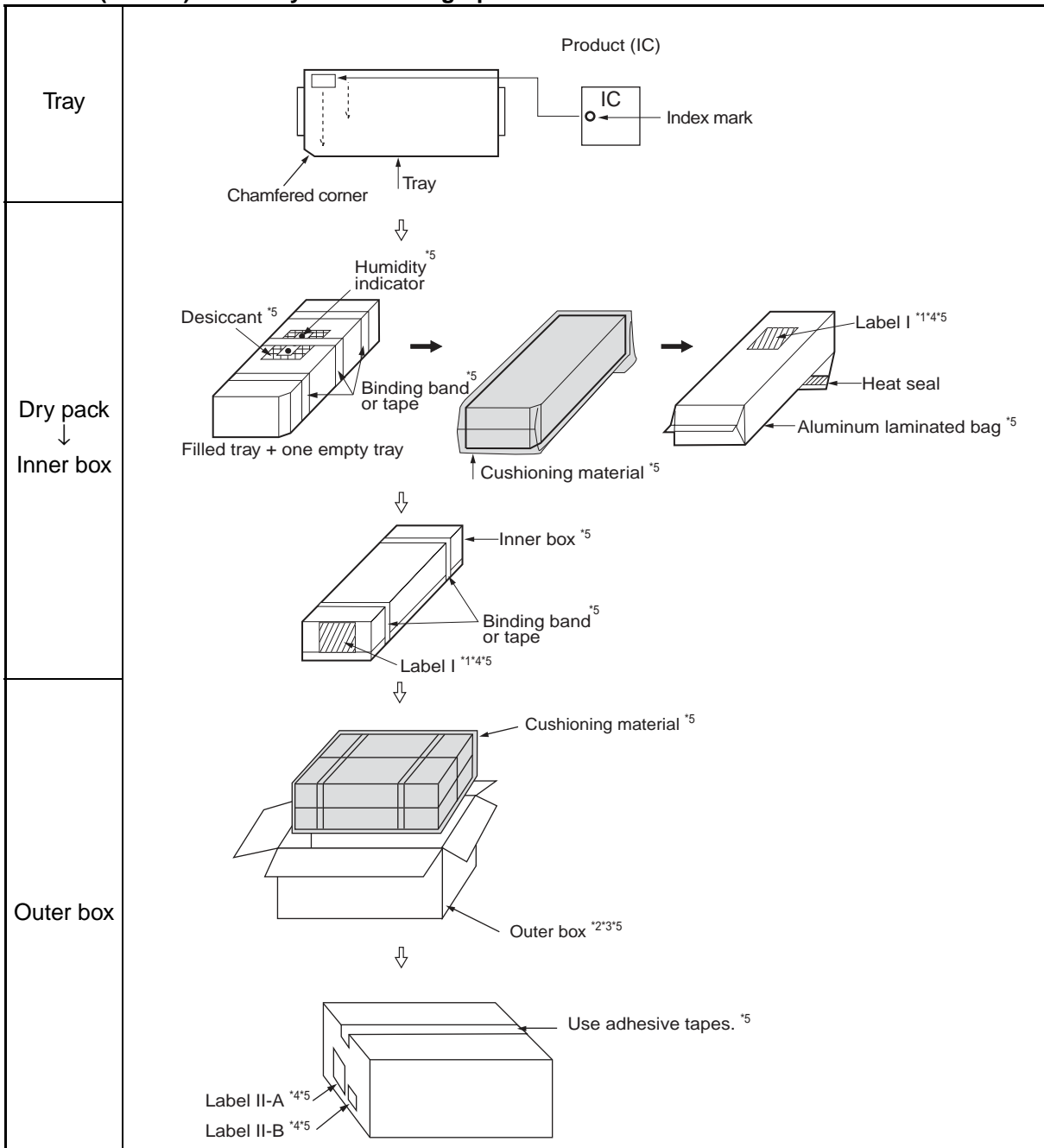

*1: For a product of which part number is suffixed with "E1", a "G" (Pb) mark is displayed to the moisture barrier bag and the inner boxes.

*2: The size of the outer box may be changed depending on the quantity of inner boxes.

*3: The space in the outer box will be filled with empty inner boxes, or cushions, etc.

*4: Please refer to an attached sheet about the indication label.

*5: The packing materials except tray may differ slightly from the color and dimensions depending on country of manufacture.

Note: The packing specifications may not be applied when the product is delivered via a distributor.

2.3 Product label indicators

Label I: Label on Inner box/Moisture Barrier Bag/ (It sticks it on the reel for the emboss taping)
 [C-3 Label (50mm × 100mm) Supplemental Label (20mm × 100mm)]

XXXXXXXXXXXXXXXX (Customer part number or FJ part number)	← C-3 Label
(3N)1 XXXXXXXXXXXXXXXX XXX (LEAD FREE mark) (Part number and quantity)	
XXXXXXXXXXXXXXXXXXXX (QC PASS)	
(3N)2 XXXXXXXXXXXXXXXX XXXXXXXX (FJ control number)	
XXXXXXXXXXXXXXXXXXXX (Quantity)	
XXXXXXXXXXXXXXXXXXXX (Customer part number or FJ part number)	
XXXXXXXXXXXXXXXXXXXX (Customer part number or FJ part number bar code)	
XXXX/XX/XX (Packed years/month/day) ASSEMBLED IN xxxx	← Perforated line
XXXXXXXXXXXXXXXXXXXX (Customer part number or FJ part number)	
XXXXXXXXXXXXXXXXXXXX (FJ control number bar code)	← Supplemental Label
XXXXXXXXXXXX (Package count) XXXX-XXX XXX	
XXXXXXXXXXXX (FJ control number) (Lot Number and quantity)	
XXXXXXXXXXXXXXXXXXXX (Comment)	

Label II-A: Label on Outer box [D Label] (100mm × 100mm)

← D Label	
発注者 XXXXXXXXXXXXXXXX (Customer Name) (CUST.)	受注者 (VENDOR) 富士通
受渡場所名 XXXXXXXXXXXX (Delivery Address) (DELIVERY POINT)	セミコンダクター株式会社
納品キー番号 XXXXXXXXXXXXXXXX (TRANS.NO.) (FJ control number)	XXX (FJ control number)
品名コード XXXXXXXXXXXXXXXX (PART NO.) (Customer part number or FJ part number)	XXX (FJ control number)
	XXXXXXXXXXXXXXXXXXXX (Part number)
品名 (PART NAME) XXXXXXXXXXXXXXXX (Part number)	
入数/納入数量 XXX/XXX (Q'TY/TOTAL Q'TY)	単位 XX (UNIT)
発注者用備考 (CUSTOMER'S REMARKS) XXXXXXXXXXXXXXXXXXXX	梱包個数 (PACKAGE COUNT) XXX/XXX
(3N)3 XXXXXXXXXXXXXXXX XXX (FJ control number + Product quantity)	
XXXXXXXXXXXXXXXXXXXX (FJ control number + Product quantity bar code)	
(3N)4 XXXXXXXXXXXXXXXX XXX (Part number + Product quantity)	
XXXXXXXXXXXXXXXXXXXX (Part number + Product quantity bar code)	
(3N)5 XXXXXXXXXXXXXXXX (FJ control number)	
XXXXXXXXXXXXXXXXXXXX (FJ control number bar code)	

Label II-B: Outer boxes product indicate

XXXXXXXXXXXXXXXXXXXX (Part number)
(Lot Number) (Count) (Quantity)
XXXX-XXX X 箱 XXX 個
XXXX-XXX X 箱 XXX 個
計 XXX 個

Note: Depending on shipment state, "Label II-A" and "Label II-B" on the external boxes might not be printed.

MB85R256F

2.4 Dimensions for Containers

(1) Dimensions for inner box

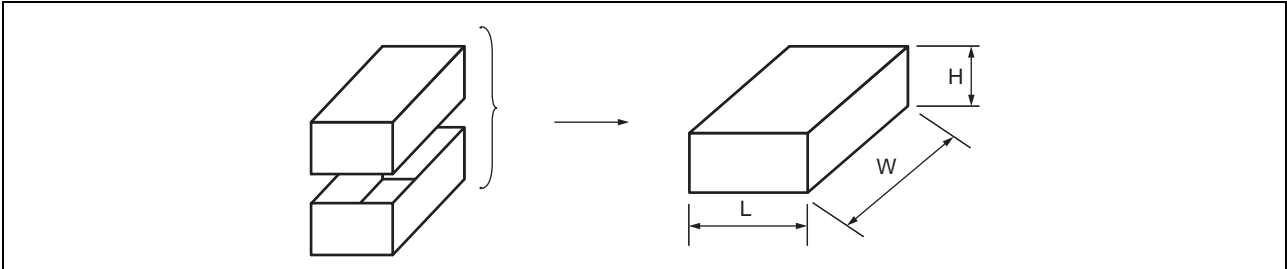

L	W	H
165	360	75

(Dimensions in mm)

(2) Dimensions for outer box

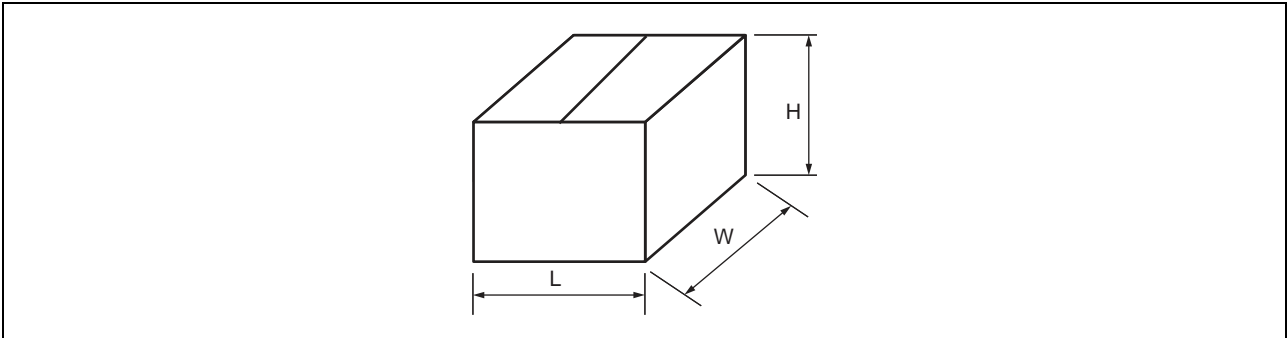

L	W	H
355	385	195

(Dimensions in mm)

3. Tape

3.1 Tape Dimensions

PKG code	Reel No	Maximum storage capacity		
		pcs/reel	pcs/inner box	pcs/outer box
FPT-28P-M17	7	1000	1000	5000

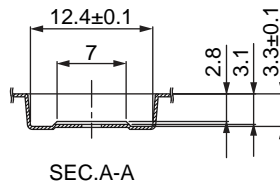
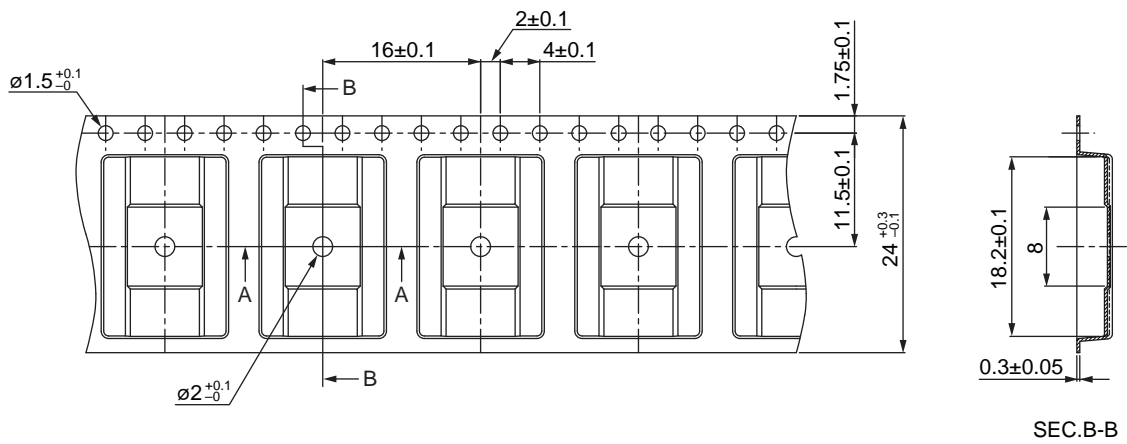

© 2012 FUJITSU SEMICONDUCTOR LIMITED F028011EELS-F : FJ990-0010-X0528-1-S-1

(Dimensions in mm)

Material : Plant origin, conductive tape

Heat proof temperature : No heat resistance.

Package should not be baked
by using tape and reel.

MB85R256F

3.2 IC orientation

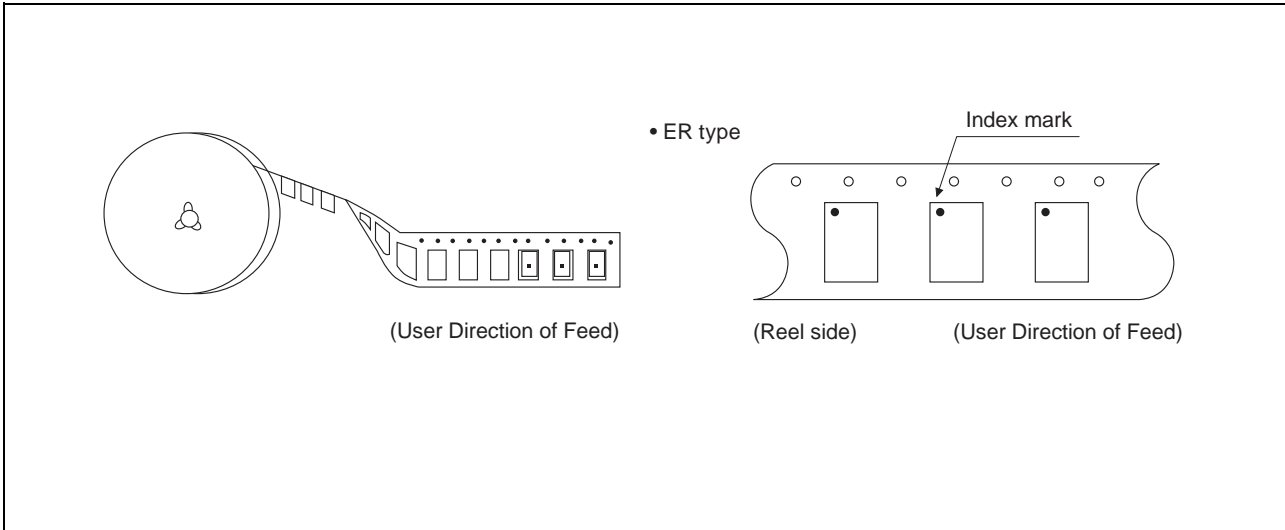

3.3 Reel dimensions

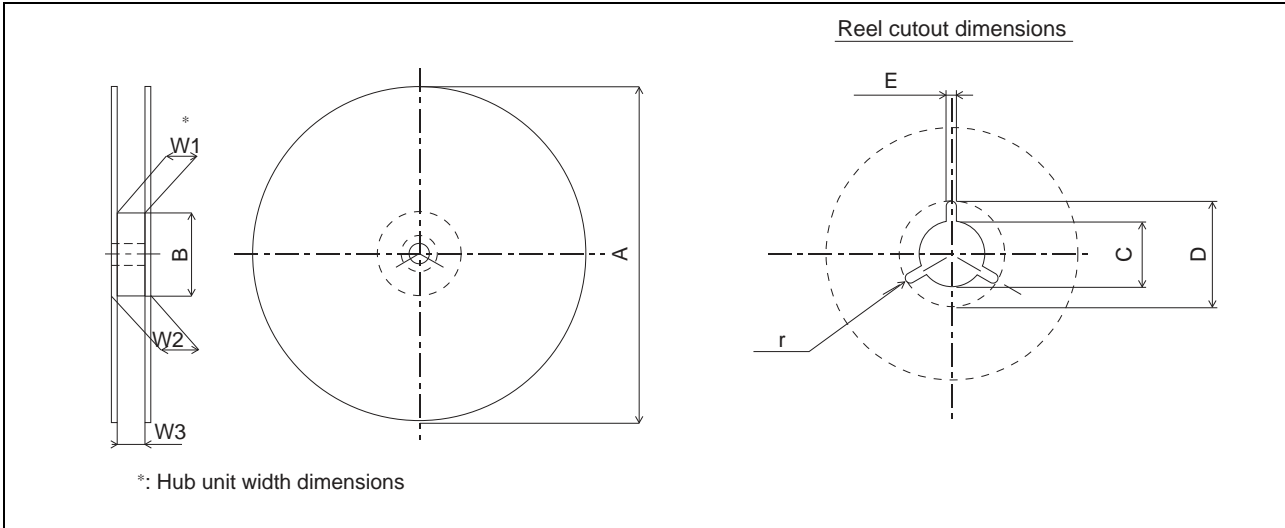

Dimensions in mm

Reel No	1	2	3	4	5	6	7	8	9	10	11	12	13	14	15
Tape width	8	12	16	24	32	44	56	12	16	24					
Symbol															
A	254 ± 2	254 ± 2	330 ± 2	254 ± 2	330 ± 2	254 ± 2	330 ± 2	330 ± 2							
B	100 ⁺² ₋₀							100 ⁺² ₋₀	150 ⁺² ₋₀	100 ⁺² ₋₀	150 ⁺² ₋₀	100 ⁺² ₋₀	100 ± 2		
C	13 ± 0.2												13 ^{+0.5} _{-0.2}		
D	21 ± 0.8												20.5 ⁺¹ _{-0.2}		
E	2 ± 0.5														
W1	8.4 ⁺² ₋₀	12.4 ⁺² ₋₀	16.4 ⁺² ₋₀	24.4 ⁺² ₋₀	32.4 ⁺² ₋₀	44.4 ⁺² ₋₀	56.4 ⁺² ₋₀	12.4 ⁺¹ ₋₀	16.4 ⁺¹ ₋₀	24.4 ^{+0.1} ₋₀					
W2	less than 14.4	less than 18.4	less than 22.4	less than 30.4	less than 38.4	less than 50.4	less than 62.4	less than 18.4	less than 22.4	less than 30.4					
W3	7.9 ~ 10.9	11.9 ~ 15.4	15.9 ~ 19.4	23.9 ~ 27.4	31.9 ~ 35.4	43.9 ~ 47.4	55.9 ~ 59.4	12.4 ~ 14.4	16.4 ~ 18.4	24.4 ~ 26.4					
r	1.0														

3.4 Taping (ϕ 330mm Reel) Dry Pack Packing Specifications

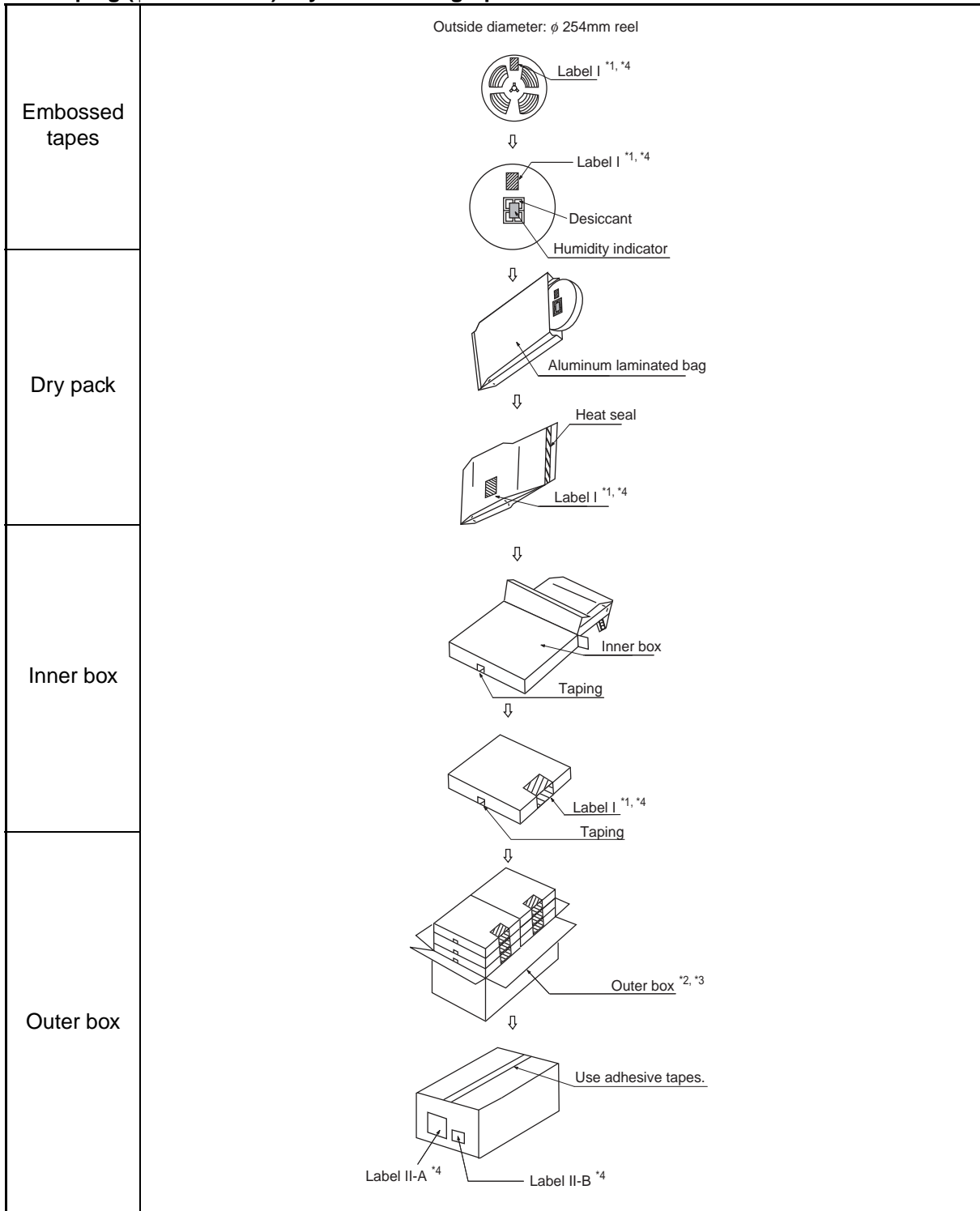

*1: For a product of which part number is suffixed with "E1", a "G" (Pb) mark is displayed to the moisture barrier bag and the inner boxes.

*2: The size of the outer box may be changed depending on the quantity of inner boxes.

*3: The space in the outer box will be filled with empty inner boxes, or cushions, etc.

*4: Please refer to an attached sheet about the indication label.

Note: The packing specifications may not be applied when the product is delivered via a distributor.

MB85R256F

3.5 Product label indicators

Label I: Label on Inner box/Moisture Barrier Bag/ (It sticks it on the reel for the emboss taping)
 [C-3 Label (50mm × 100mm) Supplemental Label (20mm × 100mm)]

XXXXXXXXXXXXXXXX (Customer part number or FJ part number)	← C-3 Label
(3N)1 XXXXXXXXXXXXXXXX XXX (LEAD FREE mark) (Part number and quantity)	
XXXXXXXXXXXXXXXXXXXX (QC PASS)	
(3N)2 XXXXXXXXXXXXXXXX XXXXXXXX (FJ control number)	
XXXXXXXXXXXXXXXXXXXX (Quantity)	
XXXXXXXXXXXXXXXXXXXX (Customer part number or FJ part number)	
XXXXXXXXXXXXXXXXXXXX (Customer part number or FJ part number bar code)	
XXXX/XX/XX (Packed years/month/day) ASSEMBLED IN xxxx	← Perforated line
XXXXXXXXXXXXXXXXXXXX (Customer part number or FJ part number)	← Supplemental Label
XXXXXXXXXXXXXXXXXXXX (FJ control number bar code)	
XXXX-XXX XXX (Package count)	
XXXX-XXX XXX (Lot Number and quantity)	
XXXXXXXXXXXX (FJ control number)	
XXXXXXXXXXXXXXXXXXXX (Comment)	

Label II-A: Label on Outer box [D Label] (100mm × 100mm)

<table border="1"> <tr> <td>発注者 XXXXXXXXXXXXXXXX (Customer Name) (CUST.)</td> <td>受注者 (VENDOR) 富士通</td> </tr> <tr> <td>受渡場所名 XXXXXXXXXXXXXXXX (Delivery Address) (DELIVERY POINT)</td> <td>セミコンダクター株式会社</td> </tr> <tr> <td>納品キー番号 XXXXXXXXXXXXXXXX (TRANS.NO.) (FJ control number)</td> <td>XXX (FJ control number)</td> </tr> <tr> <td>品名コード XXXXXXXXXXXXXXXX (PART NO.) (Customer part number or FJ part number)</td> <td>XXX (FJ control number)</td> </tr> <tr> <td></td> <td>XXXXXXXXXXXXXXXXXXXX (Part number)</td> </tr> <tr> <td colspan="2">品名 (PART NAME) XXXXXXXXXXXXXXXX (Part number)</td> </tr> <tr> <td>入数/納入数量 XXX/XXX (Q'TY/TOTAL Q'TY)</td> <td>単位 XX (UNIT)</td> </tr> <tr> <td>発注者用備考 (CUSTOMER'S REMARKS) XXXXXXXXXXXXXXXXXXXX</td> <td>梱包個数 (PACKAGE COUNT) XXX/XXX</td> </tr> </table>	発注者 XXXXXXXXXXXXXXXX (Customer Name) (CUST.)	受注者 (VENDOR) 富士通	受渡場所名 XXXXXXXXXXXXXXXX (Delivery Address) (DELIVERY POINT)	セミコンダクター株式会社	納品キー番号 XXXXXXXXXXXXXXXX (TRANS.NO.) (FJ control number)	XXX (FJ control number)	品名コード XXXXXXXXXXXXXXXX (PART NO.) (Customer part number or FJ part number)	XXX (FJ control number)		XXXXXXXXXXXXXXXXXXXX (Part number)	品名 (PART NAME) XXXXXXXXXXXXXXXX (Part number)		入数/納入数量 XXX/XXX (Q'TY/TOTAL Q'TY)	単位 XX (UNIT)	発注者用備考 (CUSTOMER'S REMARKS) XXXXXXXXXXXXXXXXXXXX	梱包個数 (PACKAGE COUNT) XXX/XXX	← D Label
発注者 XXXXXXXXXXXXXXXX (Customer Name) (CUST.)	受注者 (VENDOR) 富士通																
受渡場所名 XXXXXXXXXXXXXXXX (Delivery Address) (DELIVERY POINT)	セミコンダクター株式会社																
納品キー番号 XXXXXXXXXXXXXXXX (TRANS.NO.) (FJ control number)	XXX (FJ control number)																
品名コード XXXXXXXXXXXXXXXX (PART NO.) (Customer part number or FJ part number)	XXX (FJ control number)																
	XXXXXXXXXXXXXXXXXXXX (Part number)																
品名 (PART NAME) XXXXXXXXXXXXXXXX (Part number)																	
入数/納入数量 XXX/XXX (Q'TY/TOTAL Q'TY)	単位 XX (UNIT)																
発注者用備考 (CUSTOMER'S REMARKS) XXXXXXXXXXXXXXXXXXXX	梱包個数 (PACKAGE COUNT) XXX/XXX																
(3N)3 XXXXXXXXXXXXXXXX XXX (FJ control number + Product quantity)																	
XXXXXXXXXXXXXXXXXXXX (FJ control number + Product quantity bar code)																	
(3N)4 XXXXXXXXXXXXXXXX XXX (Part number + Product quantity)																	
XXXXXXXXXXXXXXXXXXXX (Part number + Product quantity bar code)																	
(3N)5 XXXXXXXXXXXXXXXX (FJ control number)																	
XXXXXXXXXXXXXXXXXXXX (FJ control number bar code)																	

Label II-B: Outer boxes product indicate

XXXXXXXXXXXXXXXXXXXX (Part number)		
(Lot Number)	(Count)	(Quantity)
XXXX-XXX	X 箱	XXX 個
XXXX-XXX	X 箱	XXX 個
	計	XXX 個

Note: Depending on shipment state, "Label II-A" and "Label II-B" on the external boxes might not be printed.

3.6 Dimensions for Containers

(1) Dimensions for inner box

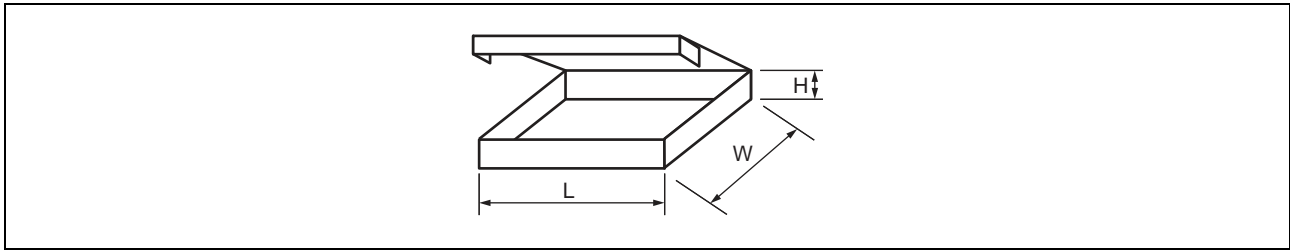

Tape width	L	W	H
12, 16	365	345	40
24, 32			50
44			65
56			75

(Dimensions in mm)

(2) Dimensions for outer box

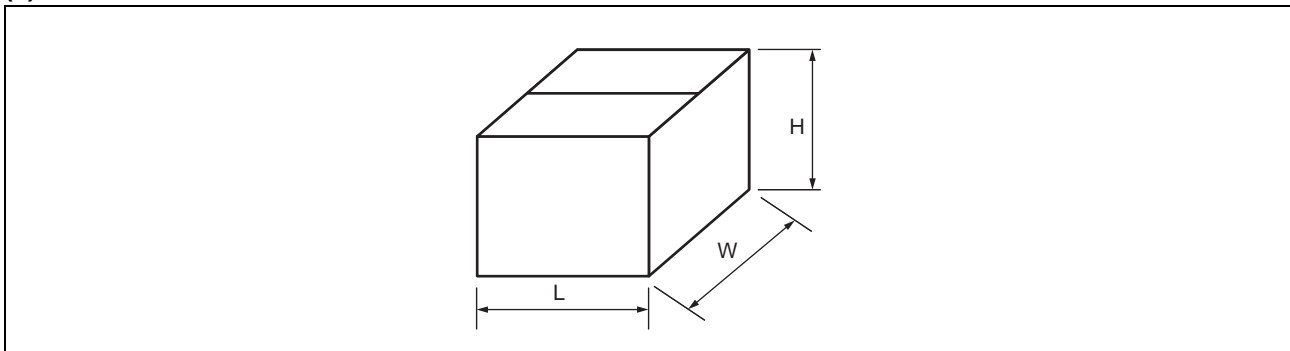

L	W	H
415	400	315

(Dimensions in mm)

■ MAJOR CHANGES IN THIS EDITION

A change on a page is indicated by a vertical line drawn on the left side of that page.

Page	Section	Change Results
1	■ FEATURES	Revised the Data retention 10 years (+ 85 °C) →10 years (+ 85 °C), 95 years (+ 55 °C), over 200 years (+ 35 °C)
5	■ ABSOLUTE MAXIMUM RANGES	Revised the Storage Temperature – 40 °C → – 55 °C
10	■ POWER ON/OFF SEQUENCE	Deleted the following description: “Because turning the power-on from an intermediate level cause malfunction, when the power is turned on, V _{DD} is required to be started from 0V (see the figure below). ” Moved the following description under the table: “If the device does not operate within the specified conditions of read cycle, write cycle or power on/off sequence, memory data can not be guaranteed. ”
	■ FRAM CHARACTERISTICS	Revised the table and Note

MEMO

MB85R256F

FUJITSU SEMICONDUCTOR LIMITED

Nomura Fudosan Shin-yokohama Bldg. 10-23, Shin-yokohama 2-Chome,
Kohoku-ku Yokohama Kanagawa 222-0033, Japan

Tel: +81-45-415-5858

<http://jp.fujitsu.com/fsl/en/>

For further information please contact:

North and South America

FUJITSU SEMICONDUCTOR AMERICA, INC.

1250 E. Arques Avenue, M/S 333

Sunnyvale, CA 94085-5401, U.S.A.

Tel: +1-408-737-5600 Fax: +1-408-737-5999

<http://us.fujitsu.com/micro/>

Asia Pacific

FUJITSU SEMICONDUCTOR ASIA PTE. LTD.

151 Lorong Chuan,

#05-08 New Tech Park 556741 Singapore

Tel : +65-6281-0770 Fax : +65-6281-0220

<http://sg.fujitsu.com/semiconductor/>

Europe

FUJITSU SEMICONDUCTOR EUROPE GmbH

Pittlerstrasse 47, 63225 Langen, Germany

Tel: +49-6103-690-0 Fax: +49-6103-690-122

<http://emea.fujitsu.com/semiconductor/>

FUJITSU SEMICONDUCTOR SHANGHAI CO., LTD.

30F, Kerry Parkside, 1155 Fang Dian Road, Pudong District,

Shanghai 201204, China

Tel : +86-21-6146-3688 Fax : +86-21-6146-3660

<http://cn.fujitsu.com/fss/>

Korea

FUJITSU SEMICONDUCTOR KOREA LTD.

902 Kosmo Tower Building, 1002 Daechi-Dong,

Gangnam-Gu, Seoul 135-280, Republic of Korea

Tel: +82-2-3484-7100 Fax: +82-2-3484-7111

<http://kr.fujitsu.com/fsk/>

FUJITSU SEMICONDUCTOR PACIFIC ASIA LTD.

2/F, Green 18 Building, Hong Kong Science Park,

Shatin, N.T., Hong Kong

Tel : +852-2736-3232 Fax : +852-2314-4207

<http://cn.fujitsu.com/fsp/>

Specifications are subject to change without notice. For further information please contact each office.

All Rights Reserved.

The contents of this document are subject to change without notice.

Customers are advised to consult with sales representatives before ordering.

The information, such as descriptions of function and application circuit examples, in this document are presented solely for the purpose of reference to show examples of operations and uses of FUJITSU SEMICONDUCTOR device; FUJITSU SEMICONDUCTOR does not warrant proper operation of the device with respect to use based on such information. When you develop equipment incorporating the device based on such information, you must assume any responsibility arising out of such use of the information.

FUJITSU SEMICONDUCTOR assumes no liability for any damages whatsoever arising out of the use of the information.

Any information in this document, including descriptions of function and schematic diagrams, shall not be construed as license of the use or exercise of any intellectual property right, such as patent right or copyright, or any other right of FUJITSU SEMICONDUCTOR or any third party or does FUJITSU SEMICONDUCTOR warrant non-infringement of any third-party's intellectual property right or other right by using such information. FUJITSU SEMICONDUCTOR assumes no liability for any infringement of the intellectual property rights or other rights of third parties which would result from the use of information contained herein.

The products described in this document are designed, developed and manufactured as contemplated for general use, including without limitation, ordinary industrial use, general office use, personal use, and household use, but are not designed, developed and manufactured as contemplated (1) for use accompanying fatal risks or dangers that, unless extremely high safety is secured, could have a serious effect to the public, and could lead directly to death, personal injury, severe physical damage or other loss (i.e., nuclear reaction control in nuclear facility, aircraft flight control, air traffic control, mass transport control, medical life support system, missile launch control in weapon system), or (2) for use requiring extremely high reliability (i.e., submersible repeater and artificial satellite).

Please note that FUJITSU SEMICONDUCTOR will not be liable against you and/or any third party for any claims or damages arising in connection with above-mentioned uses of the products.

Any semiconductor devices have an inherent chance of failure. You must protect against injury, damage or loss from such failures by incorporating safety design measures into your facility and equipment such as redundancy, fire protection, and prevention of over-current levels and other abnormal operating conditions.

Exportation/release of any products described in this document may require necessary procedures in accordance with the regulations of the Foreign Exchange and Foreign Trade Control Law of Japan and/or US export control laws.

The company names and brand names herein are the trademarks or registered trademarks of their respective owners.

Edited: Sales Promotion Department