

PRODUCT NUMBER  
SEE TABLE

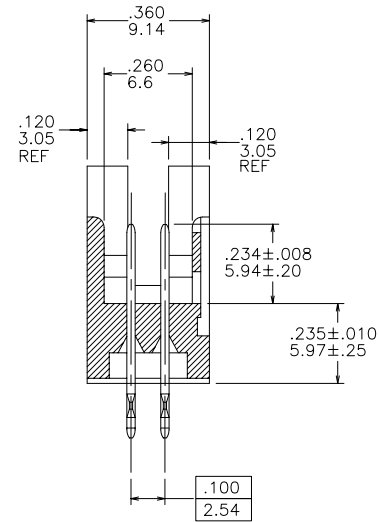
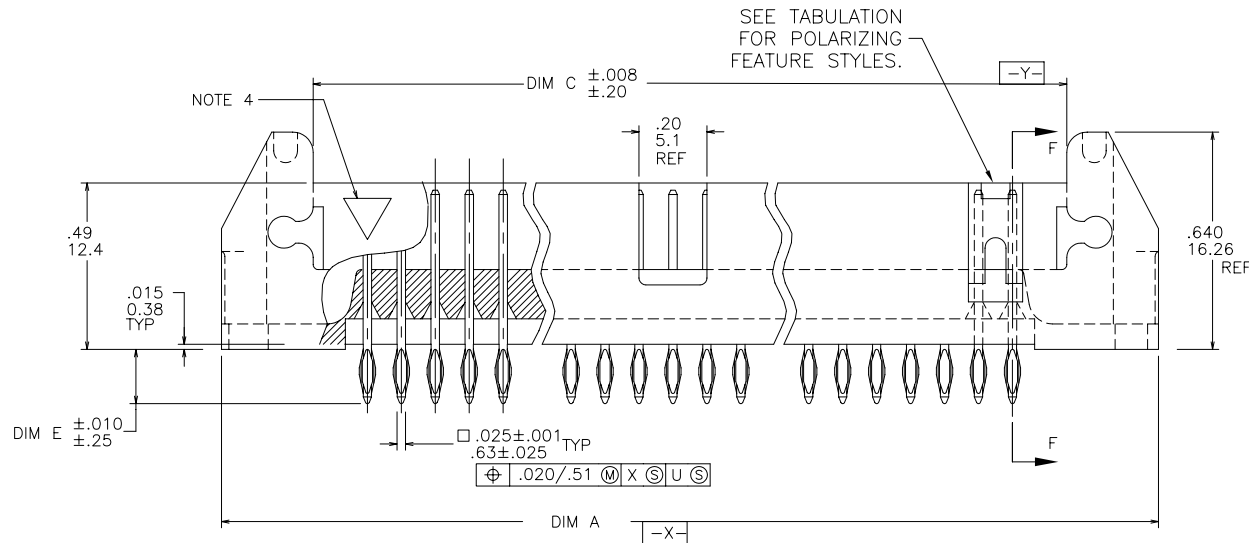
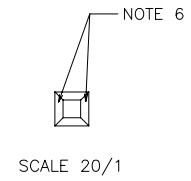
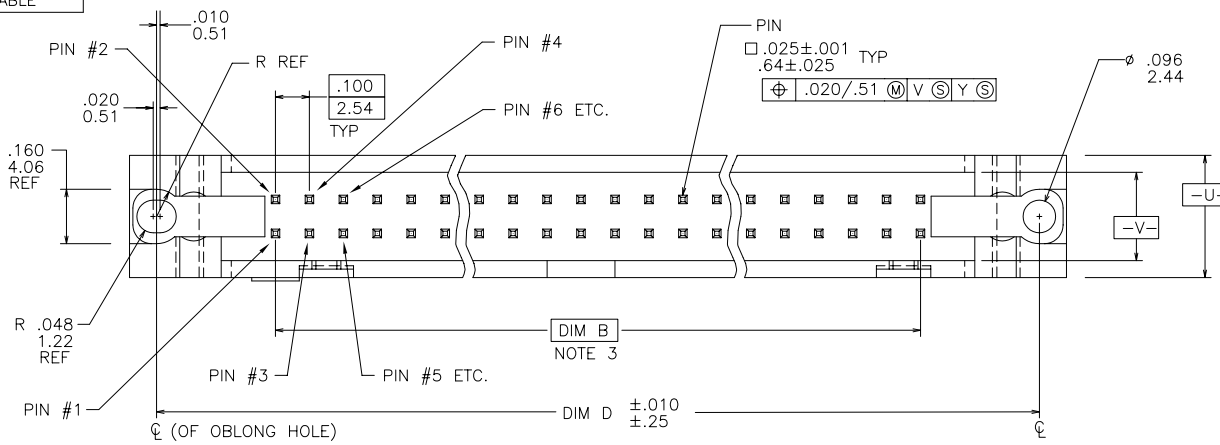

mat'l. code				surface ISO 1302 ✓				tolerance ISO 406 ISO 1101				projection INCH/MM				product family QUICKIE			
ltr ecn no dr date				tolerances unless otherwise specified				angles linear .XX±.01/.3				title P.F. HDR. ASSEMBLY SEA HORSE 4 WALL							
AA V01853 MEM 7/27/00				.xxx±.005/.13				INCH/MM				sheet 1 of 13 size							
AB V02910 MEM 12/05/00				.xxxx±.0020/.051				scale 1:1				A3							
AC V20526 RGD 3/18/02				0°±2'				FCJ				68710							
AD V21355 GIP 9/05/02				dr M. CLOUSER 3/01/90				type				Product Customer Drawing							
AE V21485 GIP 9/23/02				enr M. SMYK 3/01/90				AG AG AG AG AG AG AG AG				AG AG AG AG AG AG AG AG							
AF M05-0204 MHT 11/09/05				chr M. SMYK 3/01/90				AG AG AG AG AG AG AG AG				AG AG AG AG AG AG AG AG							
AG M07-0116 AGS 2/24/07				appd M. SMYK 3/01/90				AG AG AG AG AG AG AG AG				AG AG AG AG AG AG AG AG							
sheet		revision		AG		AG		AG		AG		AG		AG		AG		AG	
index		sheet		1		2		3		4		5		6		7		8	

	PLATING	NOTE 6
1	30u"/.76u Au OVER 50u "/1.27u Ni	NOTE 14
2	30u"/.76u GXT/GOLD FLASH	NOTE 14
4	30u"/.76u GXT DUPLEX	
4LF	30u"/.76u GXT & 100u"/2.54u Sn DUPLEX	
5	30u"/.76u GOLD DUPLEX	
5LF	30u"/.76u GOLD & 100u"/2.54u Sn DUPLEX	

NOTE 14  
NOTE 14

NOTES:

1. BODY MATERIAL; 30% GLASS FILLED POLYESTER FLAME RETARDANT PER UL 94-V0 COLOR-BLUE.  
-1XX TO -6XX BLUE PBT  
-7XX TO -9XX GREY PBT
2. UNLESS OTHERWISE SPECIFIED, 1° MAX DRAFT PERMISSIBLE ON ALL SURFACES.
- ③ DIM B BASIC DIM SHALL BE LOCATED SYMMETRICAL TO DATUM -Y-.
4. TRIANGLE, LOGO, & PART NO. AND THEIR LOCATIONS OPTIONAL.
- ⑤ PIN MATERIAL; 3/4 HD. PHOSPHOR BRONZE ALLOY UNS-C51000.
- ⑥ TWO NON-CRITICAL SIDES OF TIPS NOT PLATED. TYP BOTH ENDS.
7. RECOMMENDED MOUNTING SCREW - #2-56 FILLISTER HEAD MACHINE SCREW .25/6.35 LONG FOR .063/1.58 & .094/2.38 BOARDS, .313/7.93 LONG FOR .125/3.18 BOARDS.
8. 3 LBS/1.36 KG PIN RETENTION IN BOTH DIRECTIONS.
9. LOW PROFILE LATCHES TO BE USED WITH FEMALE CONNECTOR WITHOUT STRAIN RELIEF STANDARD LATCHES TO BE USED WITH FEMALE CONNECTORS WITH STRAIN RELIEF.
- ⑩ ADD AN "A" AFTER THE 8 DIGIT PART NUMBER FOR CUSTOMER SPECIAL.
11. RECOMMENDED PLATED-THRU-HOLE DIMENSIONS ARE:  
DRILLED HOLE: .0453/1.151±.0010/.025 DIA  
COPPER PLATING THICKNESS .001/.025 TO .003/.076  
SOLDER PLATING THICKNESS: .0003/.076 TO .0007/.0178  
OVERALL HOLE SIZE: .040/1.016±.003/.076 DIA
- ⑫ ADD "LF" SUFFIX AT THE END OF PART NUMBER FOR LEAD FREE OPTION.
- ⑬ THESE PRODUCT MEETS EUROPEAN UNION DIRECTIVES AND OTHER COUNTRY REGULATION AS DESCRIBED IN GS-22-008.
- ⑭ PLATING OPTIONS:  
MAY BE EITHER GOLD OR GXT PLATED AT MANUFACTURER'S OPTION.
15. THE PRODUCT IS NOT INTENDED TO BE EXPOSED TO A MANUFACTURING SOLDER PROCESS.

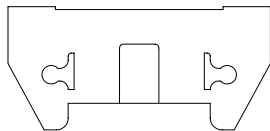

2x5  
STYLE A

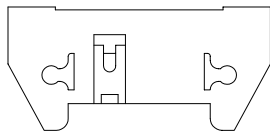

2x5  
STYLE B

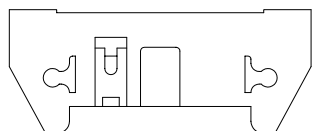

2x7  
STYLE C

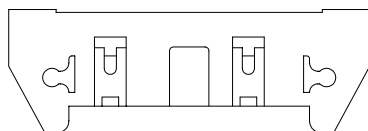

2 X 8 & LARGER  
STYLE D

mat'l. code		surface ISO 1302 ✓		tolerance ISO 406 ISO 1101		projection INCH/MM		product family QUICKIE	
ltr	ecn	no	dr	date		tolerances unless otherwise specified		title	
AG						angles	linear	P.F. HDR. ASSEMBLY SEA HORSE 4 WALL	
						0°±2'	.XX±.01/.3 .XXX±.005/.13 .XXXX±.0020/.051	scale 1:1	
						dr	M. CLOUSER	3/01/90	dwg no
						enr	M. SMYK	3/01/90	sheet 2 of 13
						chr	M. SMYK	3/01/90	size A3
						appd	M. SMYK	3/01/90	type
sheet index		revision sheet						Product Customer Drawing	

PRODUCT NUMBER	SIZE	STYLE	LATCH	DIM A	DIM B	DIM C	DIM D	DIM E	PIN PLATING	LEAD FREE PIN PLATING	LEAD FREE OPTION
68710-001	2 X 5	A	NONE	1.26/32.00	.400/10.16	.720/18.28	1.100/27.94	.160/4.06	1	1	NOTE 12
-002								.160/4.06	2	2	
-003								.610/15.49	1	1	
-004								.610/15.49	2	2	
-005								.733/18.62	1	1	
-006			NONE					.733/18.62	2	2	
-007			STD.					.160/4.06	1	1	
-008								.160/4.06	2	2	
-009								.610/15.49	1	1	
-010								.610/15.49	2	2	
-011								.733/18.62	1	1	
-012			STD.					.733/18.62	2	2	
-013			LOW PROFILE					.160/4.06	1	1	
-014								.160/4.06	2	2	
-015								.610/15.49	1	1	
-016								.610/15.49	2	2	
-017								.733/18.62	1	1	
-018		A	LOW PROFILE					.733/18.62	2	2	
-019		B	NONE					.160/4.06	1	1	
-020								.160/4.06	2	2	
-021								.610/15.49	1	1	
-022								.610/15.49	2	2	
-023								.733/18.62	1	1	
-024			NONE					.733/18.62	2	2	
-025			STD.					.160/4.06	1	1	
-026								.160/4.06	2	2	
-027								.610/15.49	1	1	
-028								.610/15.49	2	2	
-029								.733/18.62	1	1	
-030			STD.					.733/18.62	2	2	
-031			LOW PROFILE					.160/4.06	1	1	
-032								.160/4.06	2	2	
-033								.610/15.49	1	1	
-034								.610/15.49	2	2	
-035								.733/18.62	1	1	
68710-036	2 X 5	B	LOW PROFILE	1.26/32.00	.400/10.16	.720/18.28	1.100/27.94	.733/18.62	2	2	NOTE 12



Copyright FCI

mat'l. code		surface ISO 1302 ✓		tolerance ISO 406 ISO 1101		projection 		product family QUICKIE	
ltr	ecn	no	dr	date		tolerances unless otherwise specified		title	
AG						angles	linear	.XX±.01/.3 INCH/MM	
						0°±2'		.XXX±.005/.13 scale 1:1	
						dr	M. CLOUSER	3/01/90	
						enr	M. SMYK	3/01/90	
						chr	M. SMYK	3/01/90	
						appd	M. SMYK	3/01/90	
sheet index	revision sheet								dwg no 68710 sheet 3 of 13 size A3 type Product Customer Drawing

PRODUCT NUMBER	SIZE	STYLE	LATCH	DIM A	DIM B	DIM C	DIM D	DIM E	PIN PLATING SEE SHT. 2	LEAD FREE PIN PLATING	LEAD FREE OPTION
68710-037	2 X 7	C	NONE	1.46/37.08	.600/15.24	.920/23.37	1.300/33.02	.160/4.06	1	1	NOTE 12
-038								.160/4.06	2	2	
-039								.610/15.49	1	1	
-040								.610/15.49	2	2	
-041								.733/18.62	1	1	
-042			NONE					.733/18.62	2	2	
-043			STD.					.160/4.06	1	1	
-044								.160/4.06	2	2	
-045								.610/15.49	1	1	
-046								.610/15.49	2	2	
-047								.733/18.62	1	1	
-048			STD.					.733/18.62	2	2	
-049			LOW PROFILE					.160/4.06	1	1	
-050								.160/4.06	2	2	
-051								.610/15.49	1	1	
-052								.610/15.49	2	2	
-053								.733/18.62	1	1	
-054	2 X 7	C	LOW PROFILE	1.46/37.08	.600/15.24	.920/23.37	1.300/33.02	.733/18.62	2	2	
-055	2 X 8	D	NONE	1.56/39.62	.700/17.78	1.020/25.91	1.400/35.56	.160/4.06	1	1	
-056								.160/4.06	2	2	
-057								.610/15.49	1	1	
-058								.610/15.49	2	2	
-059								.733/18.62	1	1	
-060			NONE					.733/18.62	2	2	
-061			STD.					.160/4.06	1	1	
-062								.160/4.06	2	2	
-063								.610/15.49	1	1	
-064								.610/15.49	2	2	
-065								.733/18.62	1	1	
-066			STD.					.733/18.62	2	2	
-067			LOW PROFILE					.160/4.06	1	1	
-068								.160/4.06	2	2	
-069								.610/15.49	1	1	
-070								.610/15.49	2	2	
-071								.733/18.62	1	1	
68710-072	2 X 8	D	LOW PROFILE	1.56/39.62	.700/17.78	1.020/25.91	1.400/35.56	.733/18.62	2	2	NOTE 12



Copyright FCI

mat'l. code		surface ISO 1302 <input checked="" type="checkbox"/>		tolerance ISO 406 ISO 1101		projection 		product family QUICKIE	
ltr		ecn no dr		date		tolerances unless otherwise specified		title	
AG						.XX±.01/.3 linear .XXX±.005/.13 .XXX±.0020/.051		INCH/MM scale 1:1	
						dr M. CLOUSER 3/01/90		dwg no sheet 4 of 13 size	
						enr M. SMYK 3/01/90		68710 A3	
						chr M. SMYK 3/01/90		type Product Customer Drawing	
						appd M. SMYK 3/01/90			
sheet index		revision sheet							

PRODUCT NUMBER	SIZE	STYLE	LATCH	DIM A	DIM B	DIM C	DIM D	DIM E	PIN PLATING	LEAD FREE PIN PLATING	LEAD FREE OPTION
68710-073	2 X 10	D	NONE	1.76/44.70	.900/22.86	1.220/30.99	1.600/40.64	.160/4.06	1	1	NOTE 12
-074								.160/4.06	2	2	
-075								.610/15.49	1	1	
-076								.610/15.49	2	2	
-077								.733/18.62	1	1	
-078			NONE					.733/18.62	2	2	
-079			STD.					.160/4.06	1	1	
-080								.160/4.06	2	2	
-081								.610/15.49	1	1	
-082								.610/15.49	2	2	
-083								.733/18.62	1	1	
-084			STD.					.733/18.62	2	2	
-085			LOW PROFILE					.160/4.06	1	1	
-086								.160/4.06	2	2	
-087								.610/15.49	1	1	
-088								.610/15.49	2	2	
-089								.733/18.62	1	1	
-090	2 X 10	D	LOW PROFILE	1.76/44.70	.900/22.86	1.220/30.99	1.600/40.64	.733/18.62	2	2	
-091	2 X 12	D	NONE	1.96/49.78	1.100/27.94	1.420/36.07	1.800/45.72	.160/4.06	1	1	
-092								.160/4.06	2	2	
-093								.610/15.49	1	1	
-094								.610/15.49	2	2	
-095								.733/18.62	1	1	
-096			NONE					.733/18.62	2	2	
-097			STD.					.160/4.06	1	1	
-098								.160/4.06	2	2	
-099								.610/15.49	1	1	
-100								.610/15.49	2	2	
-101								.733/18.62	1	1	
-102			STD.					.733/18.62	2	2	
-103			LOW PROFILE					.160/4.06	1	1	
-104								.160/4.06	2	2	
-105								.610/15.49	1	1	
-106								.610/15.49	2	2	
-107								.733/18.62	1	1	
68710-108	2 X 12	D	LOW PROFILE	1.96/49.78	1.100/27.94	1.420/36.07	1.800/45.72	.733/18.62	2	2	NOTE 12



Copyright FCI

mat'l. code		surface ISO 1302 <input checked="" type="checkbox"/> / tolerance ISO 406 ISO 1101		projection 		product family QUICKIE	
ltr	ecn	no	dr	date	tolerances unless otherwise specified		title
AG					angles	.XX±.01/.3	P.F. HDR. ASSEMBLY SEA HORSE 4 WALL
					linear	.XXX±.005/.13	
					0°±2'	.XXXX±.0020/.051	INCH/MM
					dr	M. CLOUSER 3/01/90	scale 1:1
					enr	M. SMYK 3/01/90	
					chr	M. SMYK 3/01/90	
					appd	M. SMYK 3/01/90	
sheet index	revision sheet						dwg no 68710 sheet 5 of 13 size A3 type Product Customer Drawing

PRODUCT NUMBER	SIZE	STYLE	LATCH	DIM A	DIM B	DIM C	DIM D	DIM E	PIN PLATING	LEAD FREE PIN PLATING	LEAD FREE OPTION
68710-109	2 X 13	D	NONE	2.06/52.32	1.200/30.48	1.520/38.61	1.900/48.26	.160/4.06	1	1	NOTE 12
-110								.160/4.06	2	2	
-111								.610/15.49	1	1	
-112								.610/15.49	2	2	
-113								.733/18.62	1	1	
-114			NONE					.733/18.62	2	2	
-115			STD.					.160/4.06	1	1	
-116								.160/4.06	2	2	
-117								.610/15.49	1	1	
-118								.610/15.49	2	2	
-119								.733/18.62	1	1	
-120			STD.					.733/18.62	2	2	
-121			LOW PROFILE					.160/4.06	1	1	
-122								.160/4.06	2	2	
-123								.610/15.49	1	1	
-124								.610/15.49	2	2	
-125								.733/18.62	1	1	
-126	2 X 13	D	LOW PROFILE	2.06/52.32	1.200/30.48	1.520/38.61	1.900/48.26	.733/18.62	2	2	
-127	2 X 15	D	NONE	2.26/57.40	1.400/35.56	1.720/43.69	2.100/53.34	.160/4.06	1	1	
-128								.160/4.06	2	2	
-129								.610/15.49	1	1	
-130								.610/15.49	2	2	
-131								.733/18.62	1	1	
-132			NONE					.733/18.62	2	2	
-133			STD.					.160/4.06	1	1	
-134								.160/4.06	2	2	
-135								.610/15.49	1	1	
-136								.610/15.49	2	2	
-137								.733/18.62	1	1	
-138			STD.					.733/18.62	2	2	
-139			LOW PROFILE					.160/4.06	1	1	
-140								.160/4.06	2	2	
-141								.610/15.49	1	1	
-142								.610/15.49	2	2	
-143								.733/18.62	1	1	
68710-144	2 X 15	D	LOW PROFILE	2.26/57.40	1.400/35.56	1.720/43.69	2.100/53.34	.733/18.62	2	2	NOTE 12



FCIconnect.com

Copyright FCI

mat'l. code		surface ISO 1302 ✓		tolerance ISO 406 ISO 1101		projection 		product family QUICKIE	
ltr	ecn	no	dr	date		tolerances unless otherwise specified		title	
AG						angles	linear	P.F. HDR. ASSEMBLY SEA HORSE 4 WALL	
						0°±2'	.XX±.01/.3 .XXX±.005/.13 .XXXX±.0020/.051	INCH/MM	
						dr	M. CLOUSER	3/01/90	scale 1:1
						enr	M. SMYK	3/01/90	dwg no
						chr	M. SMYK	3/01/90	sheet 6 of 13
						appd	M. SMYK	3/01/90	size A3
sheet index		revision sheet						type Product Customer Drawing	

PRODUCT NUMBER	SIZE	STYLE	LATCH	DIM A	DIM B	DIM C	DIM D	DIM E	PIN PLATING	LEAD FREE PIN PLATING	LEAD FREE OPTION
68710-145	2 X 17	D	NONE	2.46/62.48	1.600/40.64	1.920/48.79	2.300/58.42	.160/4.06	1	1	NOTE 12
-146								.160/4.06	2	2	
-147								.610/15.49	1	1	
-148								.610/15.49	2	2	
-149								.733/18.62	1	1	
-150			NONE					.733/18.62	2	2	
-151			STD.					.160/4.06	1	1	
-152								.160/4.06	2	2	
-153								.610/15.49	1	1	
-154								.610/15.49	2	2	
-155								.733/18.62	1	1	
-156			STD.					.733/18.62	2	2	
-157			LOW PROFILE					.160/4.06	1	1	
-158								.160/4.06	2	2	
-159								.610/15.49	1	1	
-160								.610/15.49	2	2	
-161								.733/18.62	1	1	
-162	2 X 17	D	LOW PROFILE	2.46/62.48	1.600/40.64	1.920/48.79	2.300/58.42	.733/18.62	2	2	
-163	2 X 20	D	NONE	2.76/70.10	1.900/48.26	2.220/56.39	2.600/66.04	.160/4.06	1	1	
-164								.160/4.06	2	2	
-165								.610/15.49	1	1	
-166								.610/15.49	2	2	
-167								.733/18.62	1	1	
-168			NONE					.733/18.62	2	2	
-169			STD.					.160/4.06	1	1	
-170								.160/4.06	2	2	
-171								.610/15.49	1	1	
-172								.610/15.49	2	2	
-173								.733/18.62	1	1	
-174			STD.					.733/18.62	2	2	
-175			LOW PROFILE					.160/4.06	1	1	
-176								.160/4.06	2	2	
-177								.610/15.49	1	1	
-178								.610/15.49	2	2	
-179								.733/18.62	1	1	
68710-180	2 X 20	D	LOW PROFILE	2.76/70.10	1.900/48.26	2.220/56.39	2.600/66.04	.733/18.62	2	2	NOTE 12



FCIconnect.com

Copyright FCI

mat'l. code		surface ISO 1302 ✓		tolerance ISO 406 ISO 1101		projection 		product family QUICKIE	
ltr	ecn	no	dr	date		tolerances unless otherwise specified		title	
AG						angles	linear	.XX±.01/.3 INCH/MM	
						0°±2'		.XXX±.005/.13 scale 1:1	
						dr	M. CLOUSER	3/01/90	
						enr	M. SMYK	3/01/90	
						chr	M. SMYK	3/01/90	
						appd	M. SMYK	3/01/90	
sheet index		revision sheet						sheet 7 of 13 size A3	
								type Product Customer Drawing	

PRODUCT NUMBER	SIZE	STYLE	LATCH	DIM A	DIM B	DIM C	DIM D	DIM E	PIN PLATING	LEAD FREE PIN PLATING	LEAD FREE OPTION
68710-181	2 X 22	D	NONE	2.96/75.18	2.100/53.34	2.420/61.47	2.800/71.12	.160/4.06	1	1	NOTE 12
-182								.160/4.06	2	2	
-183								.610/15.49	1	1	
-184								.610/15.49	2	2	
-185								.733/18.62	1	1	
-186			NONE					.733/18.62	2	2	
-187			STD.					.160/4.06	1	1	
-188								.160/4.06	2	2	
-189								.610/15.49	1	1	
-190								.610/15.49	2	2	
-191								.733/18.62	1	1	
-192			STD.					.733/18.62	2	2	
-193			LOW PROFILE					.160/4.06	1	1	
-194								.160/4.06	2	2	
-195								.610/15.49	1	1	
-196								.610/15.49	2	2	
-197								.733/18.62	1	1	
-198	2 X 22	D	LOW PROFILE	2.96/75.18	2.100/53.34	2.420/61.47	2.800/71.12	.733/18.62	2	2	
-199	2 X 25	D	NONE	3.26/82.80	2.400/60.96	2.720/69.09	3.100/78.74	.160/4.06	1	1	
-200								.160/4.06	2	2	
-201								.610/15.49	1	1	
-202								.610/15.49	2	2	
-203								.733/18.62	1	1	
-204			NONE					.733/18.62	2	2	
-205			STD.					.160/4.06	1	1	
-206								.160/4.06	2	2	
-207								.610/15.49	1	1	
-208								.610/15.49	2	2	
-209								.733/18.62	1	1	
-210			STD.					.733/18.62	2	2	
-211			LOW PROFILE					.160/4.06	1	1	
-212								.160/4.06	2	2	
-213								.610/15.49	1	1	
-214								.610/15.49	2	2	
-215								.733/18.62	1	1	
68710-216	2 X 25	D	LOW PROFILE	3.26/82.80	2.400/60.96	2.720/69.09	3.100/78.74	.733/18.62	2	2	NOTE 12



Copyright FCI

mat'l. code		surface ISO 1302 <input checked="" type="checkbox"/>		tolerance ISO 406 ISO 1101		projection 		product family QUICKIE	
ltr	ecn	no	dr	date		tolerances unless otherwise specified		title	
AG						angles	linear	.XX±.01/.3 INCH/MM	
						0°±2'		.XXX±.005/.13 scale 1:1	
						dr	M. CLOUSER	3/01/90	
						enr	M. SMYK	3/01/90	
						chr	M. SMYK	3/01/90	
						appd	M. SMYK	3/01/90	
sheet index	revision sheet							FCI	
								dwg no 68710 sheet 8 of 13 size A3	
								type Product Customer Drawing	



PRODUCT NUMBER	SIZE	STYLE	LATCH	DIM A	DIM B	DIM C	DIM D	DIM E	PIN PLATING	LEAD FREE PIN PLATING	LEAD FREE OPTION
68710-217	2 X 30	D	NONE	3.76/95.50	2.900/73.66	3.220/81.79	3.600/91.44	.160/4.06	1	1	NOTE 12
-218								.160/4.06	2	2	
-219								.610/15.49	1	1	
-220								.610/15.49	2	2	
-221								.733/18.62	1	1	
-222			NONE					.733/18.62	2	2	
-223			STD.					.160/4.06	1	1	
-224								.160/4.06	2	2	
-225								.610/15.49	1	1	
-226								.610/15.49	2	2	
-227								.733/18.62	1	1	
-228			STD.					.733/18.62	2	2	
-229			LOW PROFILE					.160/4.06	1	1	
-230								.160/4.06	2	2	
-231								.610/15.49	1	1	
-232								.610/15.49	2	2	
-233								.733/18.62	1	1	
-234	2 X 30	D	LOW PROFILE	3.76/95.50	2.900/73.66	3.220/81.79	3.600/91.44	.733/18.62	2	2	
-235	2 X 5	A	STD.	1.26/32.00	.400/10.16	.720/18.28	1.100/27.94	.250/6.35	2	2	
-236	2 X 8	D		1.56/39.62	.700/17.78	1.020/25.91	1.400/35.56				
-237	2 X 10			1.76/44.70	.900/22.86	1.220/30.99	1.600/40.64				
-238	2 X 13			2.06/52.34	1.200/30.48	1.520/38.61	1.900/48.26				
-239	2 X 17			2.46/62.48	1.600/40.64	1.920/48.79	2.300/58.42				
-240	2 X 20			2.76/70.10	1.900/48.26	2.220/56.39	2.600/66.04				
-241	2 X 25			3.26/82.80	2.400/60.96	2.720/69.09	3.100/78.74				
-242	2 X 30	D	STD.	3.76/95.50	2.900/73.66	3.220/81.79	3.600/91.44				
-243	2 X 15	D	STD.	2.26/57.40	1.400/35.56	1.720/43.69	2.100/53.34				
-244	2 X 5	A	NONE	1.26/32.00	.400/10.16	.720/18.28	1.100/27.94				
-245	2 X 8	D		1.56/39.62	.700/17.78	1.020/25.91	1.400/35.56				
-246	2 X 10			1.76/44.70	.900/22.86	1.220/30.99	1.600/40.64				
-247	2 X 13			2.06/52.34	1.200/30.48	1.520/38.61	1.900/48.26				
-248	2 X 17			2.46/62.48	1.600/40.64	1.920/48.79	2.300/58.42				
-249	2 X 20			2.76/70.10	1.900/48.26	2.220/56.39	2.600/66.04				
-250	2 X 25			3.26/82.80	2.400/60.96	2.720/69.09	3.100/78.74				
68710-251	2 X 30			3.76/95.50	2.900/73.66	3.220/81.79	3.600/91.44	.250/6.35	2	2	NOTE 12

NOTE 10  
NOTE 10  
NOTE 10  
NOTE 10  
NOTE 10  
NOTE 10  
NOTE 10  
NOTE 10



Copyright FCI

mat'l. code		surface ISO 1302 <input checked="" type="checkbox"/>		tolerance ISO 406 ISO 1101		projection 		product family QUICKIE	
ltr	ecn	no	dr	date		tolerances unless otherwise specified		title	
AG						angles	linear	P.F. HDR. ASSEMBLY SEA HORSE 4 WALL	
						0°±2'	.XX±.01/.3 .XXX±.005/.13 .XXXX±.0020/.051	INCH/MM	
						dr	M. CLOUSER	3/01/90	scale 1:1
						enr	M. SMYK	3/01/90	dwg no
						chr	M. SMYK	3/01/90	sheet 9 of 13
						appd	M. SMYK	3/01/90	size A3
sheet index		revision sheet						type Product Customer Drawing	

PRODUCT NUMBER	SIZE	STYLE	LATCH	DIM A	DIM B	DIM C	DIM D	DIM E	PIN PLATING	LEAD FREE PIN PLATING	POLARIZED MISSING PIN	LEAD FREE OPTION
68710-252	2 x 15	D	NONE	2.26/57.40	1.400/35.56	1.720/43.69	2.100/53.34	.250/6.35	2	2		NOTE 12
68710-253	2 X 20	D	STD.	2.76/70.10	1.900/48.26	2.220/56.39	2.600/66.04	.160/4.06	2	2	PIN #20	NOTE 12
68710-309	2 x 5	B	STD.	1.26/32.00	.400/10.16	.720/18.28	1.100/27.94	.160/4.06	1	1	PIN #1	NOTE 12
68710-310	2 x 17	D	STD.	2.46/62.48	1.600/40.64	1.920/48.79	2.300/58.42	.160/4.06	1	1	PIN #25	NOTE 12



Copyright FCI

mat'l. code		surface ISO 1302 <input checked="" type="checkbox"/>		tolerance ISO 406 ISO 1101		projection 		product family QUICKIE	
ltr	ecn	no	dr	date		tolerances unless otherwise specified		title	
AG						angles	linear	INCH/MM	
						0°±2'	.XX±.01/.3	P.F. HDR. ASSEMBLY	
							.XXX±.005/.13	SEA HORSE 4 WALL	
						dr	M. CLOUSER	3/01/90	scale 1:1
						enr	M. SMYK	3/01/90	FCJ
						chr	M. SMYK	3/01/90	dwg no
						appd	M. SMYK	3/01/90	68710
sheet index		revision sheet						sheet 0 of 13 size A3	
								type Product Customer Drawing	

form: A3 1 2 3 4 5 6

PRODUCT NUMBER	SIZE	STYLE	LATCH	DIM A	DIM B	DIM C	DIM D	DIM E	PIN PLATING	LEAD FREE PIN PLATING	NOTES	PIN REMOVED	LEAD FREE OPTION
68710-400	2 x 5	A	NONE	1.26/32.00	.400/10.16	.720/18.28	1.100/27.94	.250/6.35	4	4LF			NOTE 12
-401	2 x 7	C		1.460/37.08	.600/15.24	.920/23.37	1.300/33.02						
-402	2 x 8	D		1.56/39.62	.700/17.78	1.020/25.91	1.400/35.56						
-403	2 x 10			1.76/44.70	.900/22.86	1.220/30.99	1.600/40.64						
-404	2 x 12			1.960/49.78	1.100/27.94	1.420/36.07	1.800/45.72						
-405	2 x 13			2.06/52.34	1.200/30.48	1.520/38.61	1.900/48.26						
-406	2 x 15			2.26/57.40	1.400/35.56	1.720/43.69	2.100/53.34						
-407	2 x 17			2.46/62.48	1.600/40.64	1.920/48.79	2.300/58.42						
-408	2 x 20			2.76/70.10	1.900/48.26	2.220/56.39	2.600/66.04						
-409	2 x 22			2.960/75.18	2.100/53.34	2.420/61.47	2.800/71.12						
-410	2 x 25			3.26/82.80	2.400/60.96	2.720/69.09	3.100/78.74						
-411	2 x 30	D	NONE	3.76/95.50	2.900/73.66	3.220/81.79	3.600/91.44						
-420	2 x 5	A	STD.	1.26/32.00	.400/10.16	.720/18.28	1.100/27.94				NOTE 10		
-421	2 x 7	C		1.460/37.08	.600/15.24	.920/23.37	1.300/33.02				NOTE 10		
-422	2 x 8	D		1.56/39.62	.700/17.78	1.020/25.91	1.400/35.56				NOTE 10		
-423	2 x 10			1.76/44.70	.900/22.86	1.220/30.99	1.600/40.64				NOTE 10		
-424	2 x 12			1.960/49.78	1.100/27.94	1.420/36.07	1.800/45.72				NOTE 10		
-425	2 x 13			2.06/52.34	1.200/30.48	1.520/38.61	1.900/48.26				NOTE 10		
-426	2 x 15			2.26/57.40	1.400/35.56	1.720/43.69	2.100/53.34				NOTE 10		
-427	2 x 17			2.46/62.48	1.600/40.64	1.920/48.79	2.300/58.42				NOTE 10		
-428	2 x 20			2.76/70.10	1.900/48.26	2.220/56.39	2.600/66.04				NOTE 10		
-429	2 x 22			2.960/75.18	2.100/53.34	2.420/61.47	2.800/71.12				NOTE 10		
-430	2 x 25			3.26/82.80	2.400/60.96	2.720/69.09	3.100/78.74				NOTE 10		
-431	2 x 30	D	STD.	3.76/95.50	2.900/73.66	3.220/81.79	3.600/91.44				NOTE 10		
-440	2 x 5	A	LOW PROFILE	1.26/32.00	.400/10.16	.720/18.28	1.100/27.94						
-441	2 x 7	C		1.460/37.08	.600/15.24	.920/23.37	1.300/33.02						
-442	2 x 8	D		1.56/39.62	.700/17.78	1.020/25.91	1.400/35.56						
-443	2 x 10			1.76/44.70	.900/22.86	1.220/30.99	1.600/40.64						
-444	2 x 12			1.960/49.78	1.100/27.94	1.420/36.07	1.800/45.72						
-445	2 x 13			2.06/52.34	1.200/30.48	1.520/38.61	1.900/48.26						
-446	2 x 15			2.26/57.40	1.400/35.56	1.720/43.69	2.100/53.34						
-447	2 x 17			2.46/62.48	1.600/40.64	1.920/48.79	2.300/58.42						
-448	2 x 20			2.76/70.10	1.900/48.26	2.220/56.39	2.600/66.04						
-449	2 x 22			2.960/75.18	2.100/53.34	2.420/61.47	2.800/71.12						
-450	2 x 25			3.26/82.80	2.400/60.96	2.720/69.09	3.100/78.74						
-451	2 x 30	D	LOW PROFILE	3.76/95.50	2.900/73.66	3.220/81.79	3.600/91.44	.250/6.35	4	4LF			
68710-452	2 x 7	C	STD.	1.460/37.08	.600/15.24	.920/23.37	1.300/33.02	.160/4.06	1		NOTE 10	14	NOTE 12



Copyright FCI

mat'l. code		surface ISO 1302 <input checked="" type="checkbox"/>		tolerance ISO 406 ISO 1101		projection 		product family QUICKIE	
ltr	ecn	no	dr	date		tolerances unless otherwise specified		title	
AG						angles	linear	P.F. HDR. ASSEMBLY SEA HORSE 4 WALL	
						0°±2'	.XX±.01/.3 .XXX±.005/.13 .XXXX±.0020/.051	INCH/MM	
						dr	M. CLOUSER	3/01/90	scale 1:1
						enr	M. SMYK	3/01/90	sheet 11 of 13
						chr	M. SMYK	3/01/90	size A3
						appd	M. SMYK	3/01/90	type Product Customer Drawing
sheet index	revision sheet								

PRODUCT NUMBER	SIZE	STYLE	LATCH	DIM A	DIM B	DIM C	DIM D	DIM E	PIN PLATING	LEAD FREE PIN PLATING	POSITION OMITTED	LEAD FREE OPTION
68710-500	2 x 5	A	NONE	1.260/32.00	.400/10.16	.720/18.28	1.100/27.94	.160/4.06	5	5LF		NOTE 12
-501	2 x 7	C		1.460/37.08	.600/15.24	.920/23.37	1.300/33.02					
-502	2 x 8	D		1.560/39.62	.700/17.78	1.020/25.91	1.400/35.56					
-503	2 x 10			1.760/44.70	.900/22.86	1.220/30.99	1.600/40.64					
-504	2 x 12			1.960/49.78	1.100/27.49	1.420/36.07	1.800/45.72					
-505	2 x 13			2.060/52.34	1.200/30.48	1.520/38.61	1.900/48.26					
-506	2 x 15			2.260/57.40	1.400/35.56	1.720/43.69	2.100/53.34					
-507	2 x 17			2.460/62.48	1.600/40.64	1.920/48.79	2.300/58.42					
-508	2 x 20			2.760/70.10	1.900/48.26	2.220/56.39	2.600/66.04					
-509	2 x 22			2.960/75.18	2.100/53.34	2.420/61.47	2.800/71.12					
-510	2 x 25			3.260/82.80	2.400/60.96	2.720/69.09	3.100/78.74					
-511	2 x 30	D	NONE	3.760/95.50	2.900/73.66	3.220/81.79	3.600/91.44					
-520	2 x 5	A	STD.	1.260/32.00	.400/10.16	.720/18.28	1.100/27.94					
-521	2 x 7	C		1.460/37.08	.600/15.24	.920/23.37	1.300/33.02					
-522	2 x 8	D		1.560/39.62	.700/17.78	1.020/25.91	1.400/35.56					
-523	2 x 10			1.760/44.70	.900/22.86	1.220/30.99	1.600/40.64					
-524	2 x 12			1.960/49.78	1.100/27.49	1.420/36.07	1.800/45.72					
-525	2 x 13			2.060/52.34	1.200/30.48	1.520/38.61	1.900/48.26					
-526	2 x 15			2.260/57.40	1.400/35.56	1.720/43.69	2.100/53.34					
-527	2 x 17			2.460/62.48	1.600/40.64	1.920/48.79	2.300/58.42					
-528	2 x 20			2.760/70.10	1.900/48.26	2.220/56.39	2.600/66.04					
-529	2 x 22			2.960/75.18	2.100/53.34	2.420/61.47	2.800/71.12					
-530	2 x 25			3.260/82.80	2.400/60.96	2.720/69.09	3.100/78.74					
-531	2 x 30	D	STD.	3.760/95.50	2.900/73.66	3.220/81.79	3.600/91.44					
-540	2 x 5	A	LOW PROFILE	1.260/32.00	.400/10.16	.720/18.28	1.100/27.94					
-541	2 x 7	C		1.460/37.08	.600/15.24	.920/23.37	1.300/33.02					
-542	2 x 8	D		1.560/39.62	.700/17.78	1.020/25.91	1.400/35.56					
-543	2 x 10			1.760/44.70	.900/22.86	1.220/30.99	1.600/40.64					
-544	2 x 12			1.960/49.78	1.100/27.49	1.420/36.07	1.800/45.72					
-545	2 x 13			2.060/52.34	1.200/30.48	1.520/38.61	1.900/48.26					
-546	2 x 15			2.260/57.40	1.400/35.56	1.720/43.69	2.100/53.34					
-547	2 x 17			2.460/62.48	1.600/40.64	1.920/48.79	2.300/58.42					
-548	2 x 20			2.760/70.10	1.900/48.26	2.220/56.39	2.600/66.04					
-549	2 x 22			2.960/75.18	2.100/53.34	2.420/61.47	2.800/71.12					
-550	2 x 25			3.260/82.80	2.400/60.96	2.720/69.09	3.100/78.74					
-551	2 x 30		LOW PROFILE	3.760/95.50	2.900/73.66	3.220/81.79	3.600/91.44					
-552	2 x 8		NONE	1.560/39.62	.700/17.78	1.020/25.91	1.400/35.56				2	
-553	2 x 8		STD	1.560/39.62	.700/17.78	1.020/25.91	1.400/35.56				2	
-554	2 x 10		NONE	1.760/44.70	.900/22.86	1.220/30.99	1.600/40.64				2	
-555	2 x 10		STD	1.760/44.70	.900/22.86	1.220/30.99	1.600/40.64			5	5LF	2
68710-556	2 x 20	D	STD	2.760/70.10	1.900/48.26	2.220/56.39	2.600/66.04	.160/4.06	1	1	1,15,16,17,18,19,20,21,22,37,38,39,40	NOTE 12

NOTE 10  
NOTE 10  
NOTE 10  
NOTE 10  
NOTE 10  
NOTE 10  
NOTE 10  
NOTE 10  
NOTE 10  
NOTE 10  
NOTE 10  
NOTE 10



Copyright FCI

mat'l. code		surface ISO 1302 <input checked="" type="checkbox"/>		tolerance ISO 406 ISO 1101		projection 		product family QUICKIE	
ltr	ecn	no	dr	date		tolerances unless otherwise specified		title	
AG						angles	linear	INCH/MM	
						0°±2'	.XX±.01/.3 .XXX±.005/.13 .XXXX±.0020/.051	scale 1:1	
						dr	M. CLOUSER	3/01/90	sheet 2 of 13
						enr	M. SMYK	3/01/90	size
						chr	M. SMYK	3/01/90	A3
						appd	M. SMYK	3/01/90	type
sheet index		revision sheet						Product Customer Drawing	

PRODUCT NUMBER	SIZE	STYLE	LATCH	DIM A	DIM B	DIM C	DIM D	DIM E	PIN PLATING	LEAD FREE PIN PLATING	REMARKS	PINS REMOVED	LEAD FREE OPTION
68710-620	2 x 5	A	STD.	1.260/32.00	.400/10.16	.720/18.28	1.100/27.94	.120/3.05	2	2	MINI-LIF		NOTE 12
-621	2 x 7	C	STD.	1.460/37.08	.600/15.24	.920/23.37	1.300/33.02	.120/3.05	2	2	MINI-LIF		
-640	2 x 20	D	STD.	2.760/70.10	1.900/48.26	2.220/56.39	2.600/66.04	.120/3.05	2	2	MINI-LIF		
-650	2 x 25	D	STD.	3.260/82.80	2.400/60.96	2.720/69.09	3.100/78.74	.120/3.05	2	2	MINI-LIF		
-651	2 x 22	D	STD.	2.960/75.18	2.100/53.34	2.420/61.47	2.800/71.12	.160/4.06	1	1		REMOVE PINS: 2,3,6,7,10,11,14,15,18,19,22,23, 26,27,30,31,34,35,38,39,42,43 & 44	
-652	2 x 5	A	STD.	1.260/32.00	.400/10.16	.720/18.29	1.100/27.94					REMOVE PINS: 10	
-653	2 x 5	B	STD.	1.260/32.00	.400/10.16	.720/18.29	1.100/27.94					REMOVE PINS: 10	
-654	2 x 7	C	STD.	1.460/37.08	.600/15.24	.920/23.37	1.300/33.02					REMOVE PINS: 14	
-710	2 x 5	A	NONE	1.260/32.00	.400/10.16	.720/18.28	1.100/27.94						
-714	2 x 7	C		1.460/37.08	.600/15.24	.920/23.37	1.300/33.02						
-716	2 x 8	D		1.560/39.62	.700/17.78	1.020/25.91	1.400/35.56						
-720	2 x 10			1.760/44.70	.900/22.86	1.220/30.99	1.600/40.64						
-726	2 x 13			2.060/52.32	1.200/30.48	1.520/38.61	1.900/48.26						
-734	2 x 17			2.460/62.48	1.600/40.64	1.920/48.79	2.300/58.42						
-740	2 x 20			2.760/70.10	1.900/48.26	2.220/56.39	2.600/66.04						
-750	2 x 25			3.260/82.80	2.400/60.96	2.720/69.09	3.100/78.74						
-760	2 x 30	D	NONE	3.760/95.50	2.900/73.66	3.220/81.79	3.600/91.44						
-810	2 x 5	A	STD.	1.260/32.00	.400/10.16	.720/18.29	1.100/27.94						
-814	2 x 7	C		1.460/37.08	.600/15.24	.920/23.37	1.300/33.02						
-816	2 x 8	D		1.560/39.62	.700/17.78	1.020/25.91	1.400/35.56						
-820	2 x 10			1.760/44.70	.900/22.86	1.220/30.99	1.600/40.64						
-826	2 x 13			2.060/52.32	1.200/30.48	1.520/38.61	1.900/48.26						
-834	2 x 17			2.460/62.48	1.600/40.64	1.920/48.79	2.300/58.42						
-840	2 x 20			2.760/70.10	1.900/48.26	2.220/56.39	2.600/66.04						
-850	2 x 25			3.260/82.80	2.400/60.96	2.720/69.09	3.100/78.74						
-860	2 x 30	D	STD.	3.760/95.50	2.900/73.66	3.220/81.79	3.600/91.44						
-910	2 x 5	A	LOW	1.260/32.00	.400/10.16	.720/18.29	1.100/27.94						
-914	2 x 7	C		1.460/37.08	.600/15.24	.920/23.37	1.300/33.02						
-916	2 x 8	D		1.560/39.62	.700/17.78	1.020/25.91	1.400/35.56						
-920	2 x 10			1.760/44.70	.900/22.86	1.220/30.99	1.600/40.64						
-926	2 x 13			2.060/52.32	1.200/30.48	1.520/38.61	1.900/48.26						
-934	2 x 17			2.460/62.48	1.600/40.64	1.920/48.79	2.300/58.42						
-940	2 x 20			2.760/70.10	1.900/48.26	2.220/56.39	2.600/66.04						
-950	2 x 25			3.260/82.80	2.400/60.96	2.720/69.09	3.100/78.74						
68710-960	2 x 30	D	LOW	3.760/95.50	2.900/73.66	3.220/81.79	3.600/91.44	.160/4.06	1	1			NOTE 12



Copyright FCI

mat'l. code		surface ISO 1302 <input checked="" type="checkbox"/>		tolerance ISO 406 ISO 1101		projection 		product family QUICKIE	
ltr	ecn	no	dr	date		tolerances unless otherwise specified		title	
AG						angles	linear	P.F. HDR. ASSEMBLY SEA HORSE 4 WALL	
						0°±2'	.XX±.01/.3 .XXX±.005/.13 .XXXX±.0020/.051	INCH/MM	
						dr	M. CLOUSER	3/01/90	scale 1:1
						enr	M. SMYK	3/01/90	sheet 3 of 13
						chr	M. SMYK	3/01/90	size A3
						appd	M. SMYK	3/01/90	type Product Customer Drawing
sheet index	revision sheet								