

REVISIONS					
P	LTR	DESCRIPTION	DATE	DWN	APVD
G2		REVISED PER ECR-22-160893	15DEC2022	DB	BW

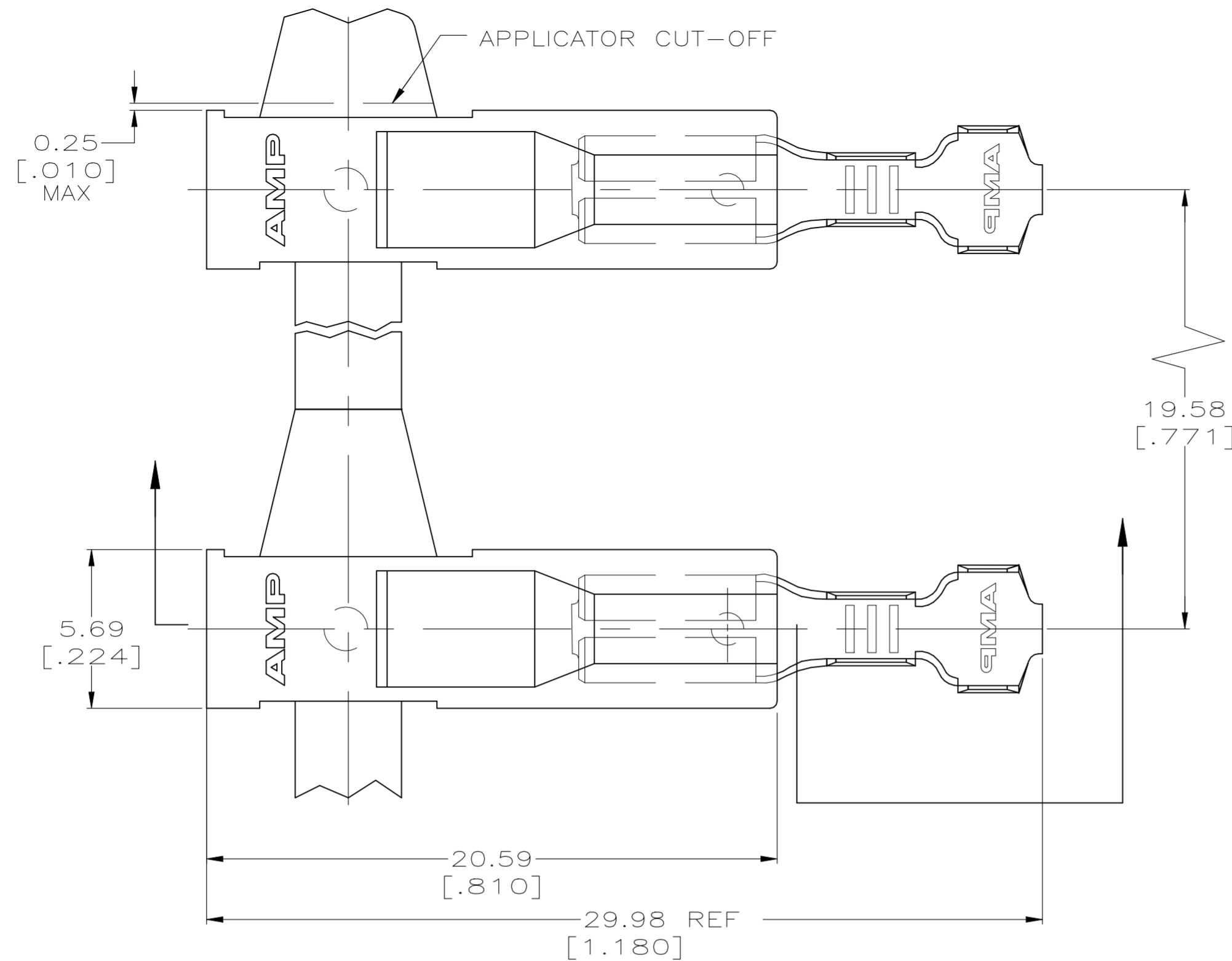

- 1 MATING TAB THK IS 0.81±0.025[.032±.001]
- 2 WIRE SIZE IS [#22-#18] AWG.
- 3 INSULATION RANGE IS 2.03-3.05[.080-.120] DIA.
- △ PREPRODUCTION - FASR REQ

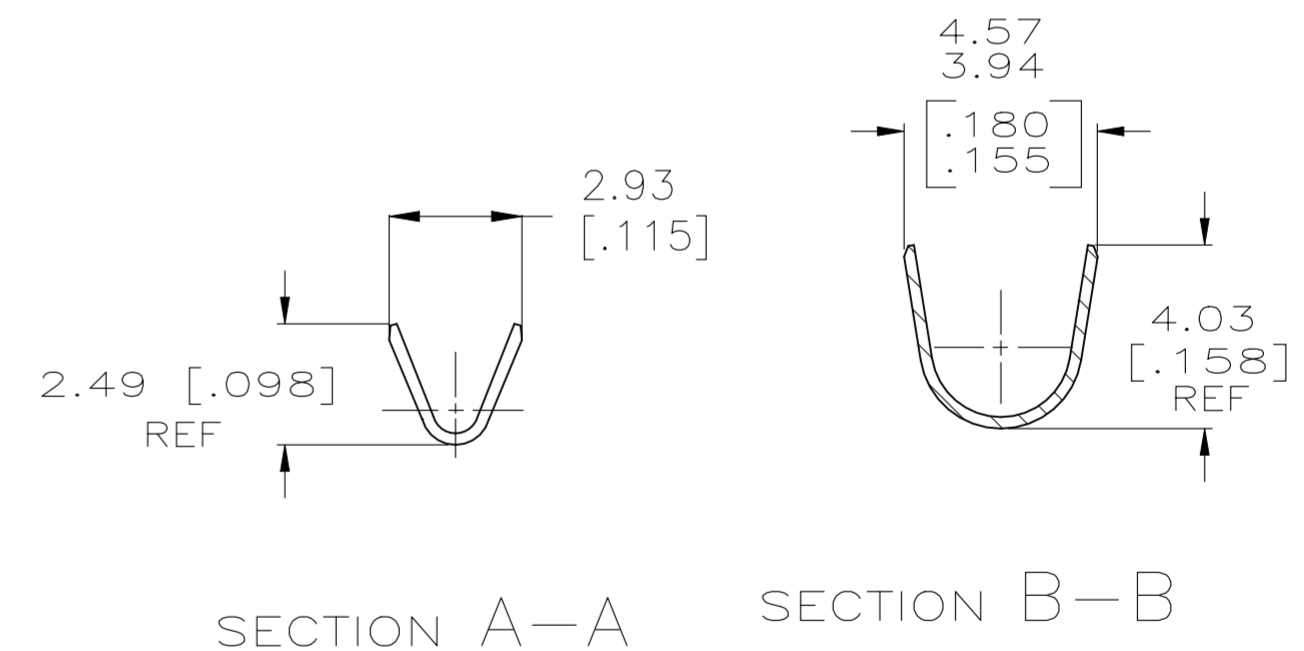
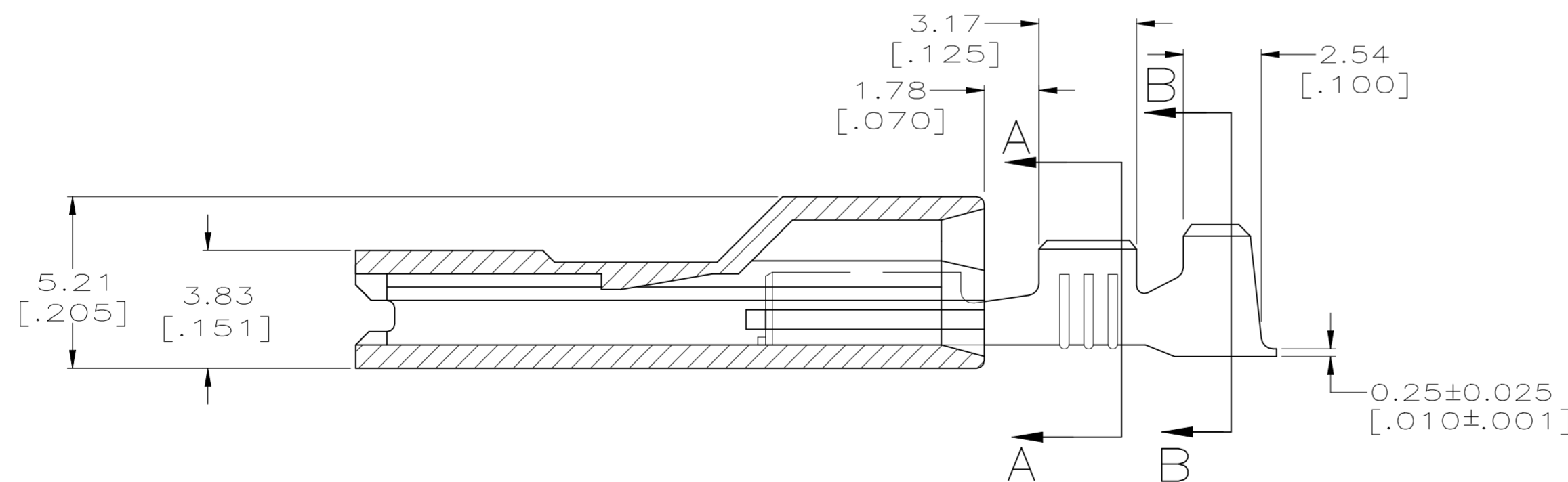

OBSOLETE	TIN PLATE	521436-2
	TERMINAL FINISH	△ 521436-1
PART NO.		
DWN JR RUTH 22OCT01 CHK J HUMMEL 22OCT01 APVD J HUMMEL 22OCT01 PRODUCT SPEC 108-1285 APPLICATION SPEC 114-2124		NAME ASSEMBLY, RECEPTACLE, ULTRA-POD, 2.79 [.110] SERIES
SIZE	CAGE CODE	DRAWING NO
A2	00779	C=521436
WEIGHT	0.000000	RESTRICTED TO
CUSTOMER DRAWING	SCALE 6:1	SHEET 1 OF 1
		REV G2

THIS DRAWING IS A CONTROLLED DOCUMENT.	
DIMENSIONS:	TOLERANCES UNLESS OTHERWISE SPECIFIED:
mm [INCHES]	
0 PLC ± -	
1 PLC ± -	
2 PLC ± 0.25 [.010]	
3 PLC ± -	
4 PLC ± -	
ANGLES ± -	
MATERIAL	FINISH
TERMINAL - BRASS	TERMINAL - SEE TABLE
HSG - 6/6 NYLON, V2	HOUSING - NATURAL