

April 1995

15A, 700V - 1000V Hyperfast Diodes

Features

- Hyperfast with Soft Recovery <60ns
- Operating Temperature +175°C
- Reverse Voltage Up To 1000V
- Avalanche Energy Rated
- Planar Construction

Applications

- Switching Power Supplies
- Power Switching Circuits
- General Purpose

Description

RHRP1570, RHRP1580, RHRP1590 and RHRP15100 (TA49062) are hyperfast diodes with soft recovery characteristics ($t_{RR} < 60ns$). They have half the recovery time of ultrafast diodes and are silicon nitride passivated ion-implanted epitaxial planar construction.

These devices are intended for use as freewheeling/clamping diodes and rectifiers in a variety of switching power supplies and other power switching applications. Their low stored charge and hyperfast soft recovery minimize ringing and electrical noise in many power switching circuits reducing power loss in the switching transistors.

PACKAGING AVAILABILITY

PART NUMBER	PACKAGE	BRAND
RHRP1570	TO-220AC	RHRP1570
RHRP1580	TO-220AC	RHRP1580
RHRP1590	TO-220AC	RHRP1590
RHRP15100	TO-220AC	RHR15100

NOTE: When ordering, use the entire part number.

Package

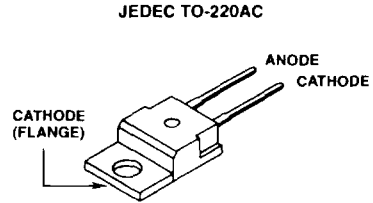

Symbol



Absolute Maximum Ratings $T_C = +25^\circ C$, Unless Otherwise Specified

	RHRP1570	RHRP1580	RHRP1590	RHRP15100	UNITS
Peak Repetitive Reverse Voltage V_{RRM}	700	800	900	1000	V
Working Peak Reverse Voltage V_{RWM}	700	800	900	1000	V
DC Blocking Voltage V_R	700	800	900	1000	V
Average Rectified Forward Current $I_{F(AV)}$ ($T_C = +130^\circ C$)	15	15	15	15	A
Repetitive Peak Surge Current I_{FSM} (Square Wave, 20kHz)	30	30	30	30	A
Nonrepetitive Peak Surge Current I_{FSM} (Halfwave, 1 Phase, 60Hz)	200	200	200	200	A
Maximum Power Dissipation P_D	100	100	100	100	W
Avalanche Energy (L = 40mH) E_{AVL}	20	20	20	20	mj
Operating and Storage Temperature T_{STG}, T_J	-65 to +175	-65 to +175	-65 to +175	-65 to +175	°C

Specifications RHRP1570, RHRP1580, RHRP1590, RHRP15100

Electrical Specifications $T_C = +25^\circ\text{C}$, Unless Otherwise Specified

SYMBOL	TEST CONDITION	RHRP1570			RHRP1580			RHRP1590			RHRP15100			UNITS
		MIN	TYP	MAX	MIN	TYP	MAX	MIN	TYP	MAX	MIN	TYP	MAX	
V_F	$I_F = 15\text{A}, T_C = +25^\circ\text{C}$	-	-	3.0	-	-	3.0	-	-	3.0	-	-	3.0	V
	$I_F = 15\text{A}, T_C = +150^\circ\text{C}$	-	-	2.5	-	-	2.5	-	-	2.5	-	-	2.5	V
I_R	$V_R = 700\text{V}, T_C = +25^\circ\text{C}$	-	-	100	-	-	-	-	-	-	-	-	-	μA
	$V_R = 800\text{V}, T_C = +25^\circ\text{C}$	-	-	-	-	-	100	-	-	-	-	-	-	μA
	$V_R = 900\text{V}, T_C = +25^\circ\text{C}$	-	-	-	-	-	-	-	-	100	-	-	-	μA
	$V_R = 1000\text{V}, T_C = +25^\circ\text{C}$	-	-	-	-	-	-	-	-	-	-	-	100	μA
I_R	$V_R = 700\text{V}, T_C = +150^\circ\text{C}$	-	-	500	-	-	-	-	-	-	-	-	-	μA
	$V_R = 800\text{V}, T_C = +150^\circ\text{C}$	-	-	-	-	-	500	-	-	-	-	-	-	μA
	$V_R = 900\text{V}, T_C = +150^\circ\text{C}$	-	-	-	-	-	-	-	-	500	-	-	-	μA
	$V_R = 1000\text{V}, T_C = +150^\circ\text{C}$	-	-	-	-	-	-	-	-	-	-	-	500	μA
t_{RR}	$I_F = 1\text{A}, dI_F/dt = 100\text{A}/\mu\text{s}$	-	-	60	-	-	60	-	-	60	-	-	60	ns
	$I_F = 15\text{A}, dI_F/dt = 100\text{A}/\mu\text{s}$	-	-	70	-	-	70	-	-	70	-	-	70	ns
t_A	$I_F = 15\text{A}, dI_F/dt = 100\text{A}/\mu\text{s}$	-	40	-	-	40	-	-	40	-	-	40	-	ns
t_B	$I_F = 15\text{A}, dI_F/dt = 100\text{A}/\mu\text{s}$	-	25	-	-	25	-	-	25	-	-	25	-	ns
Q_{RR}	$I_F = 15\text{A}, dI_F/dt = 100\text{A}/\mu\text{s}$	-	160	-	-	160	-	-	160	-	-	160	-	nC
C_J	$V_R = 10\text{V}, I_F = 0\text{A}$	-	66	-	-	66	-	-	66	-	-	66	-	pF
$R_{\theta JC}$		-	-	1.5	-	-	1.5	-	-	1.5	-	-	1.5	$^\circ\text{C}/\text{W}$

DEFINITIONS

- V_F = Instantaneous forward voltage ($p_w = 300\mu\text{s}$, $D = 2\%$).
- I_R = Instantaneous reverse current.
- t_{RR} = Reverse recovery time (Figure 2), summation of $t_A + t_B$.
- t_A = Time to reach peak reverse current (See Figure 2).
- t_B = Time from peak I_{RM} to projected zero crossing of I_{RM} based on a straight line from peak I_{RM} through 25% of I_{RM} (See Figure 2).
- $R_{\theta JC}$ = Thermal resistance junction to case.
- E_{AVL} = Controlled avalanche energy (See Figures 10 and 11).
- p_w = pulse width.
- D = duty cycle.

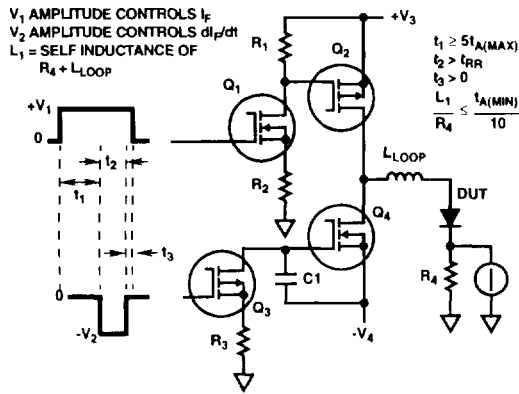

FIGURE 1. t_{RR} TEST CIRCUIT

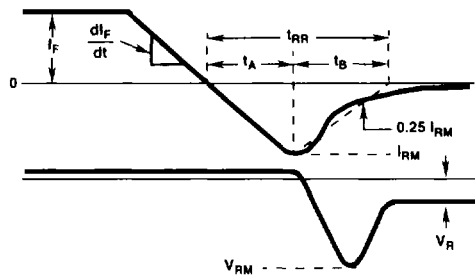

FIGURE 2. t_{RR} WAVEFORMS AND DEFINITIONS

7

**HYPERFAST
SINGLE DIODES**

Typical Performance Curves

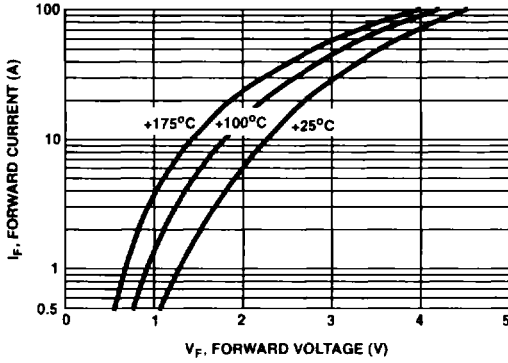

FIGURE 3. TYPICAL FORWARD CURRENT vs FORWARD VOLTAGE DROP

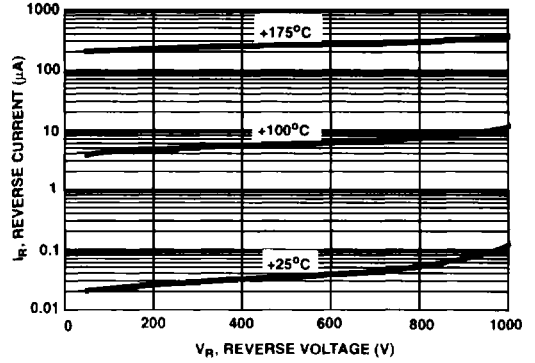

FIGURE 4. TYPICAL REVERSE CURRENT vs REVERSE VOLTAGE

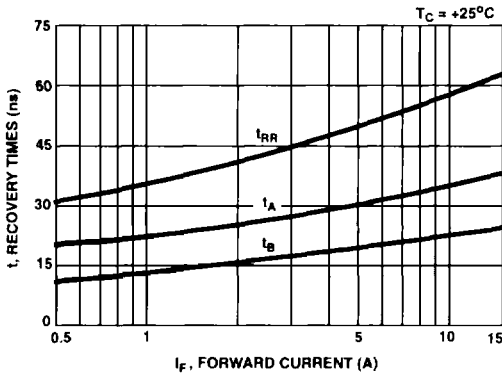

FIGURE 5. TYPICAL t_{RR} , t_A AND t_B CURVES vs FORWARD CURRENT AT 25°C

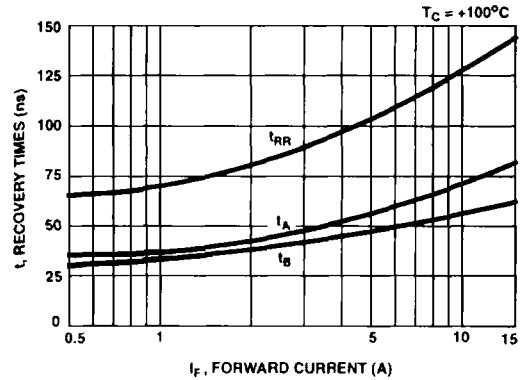

FIGURE 6. TYPICAL t_{RR} , t_A AND t_B CURVES vs FORWARD CURRENT AT 100°C

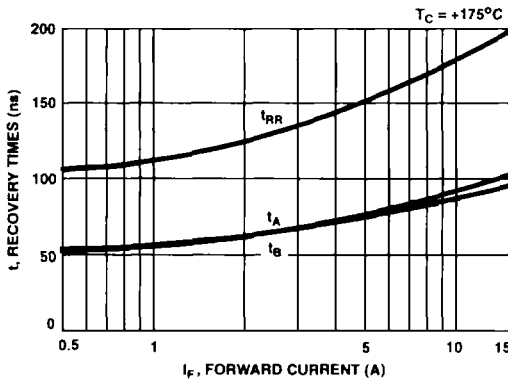

FIGURE 7. TYPICAL t_{RR} , t_A AND t_B CURVES vs FORWARD CURRENT AT 175°C

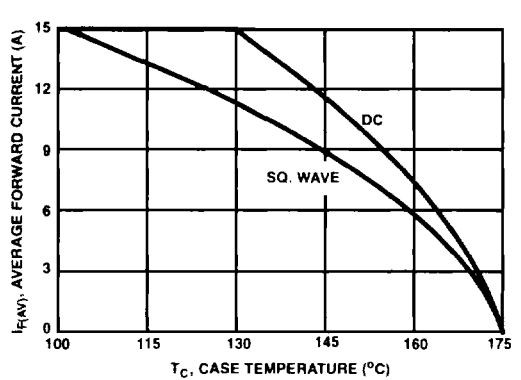

FIGURE 8. CURRENT DERATING CURVE FOR ALL TYPES

Typical Performance Curves (Continued)

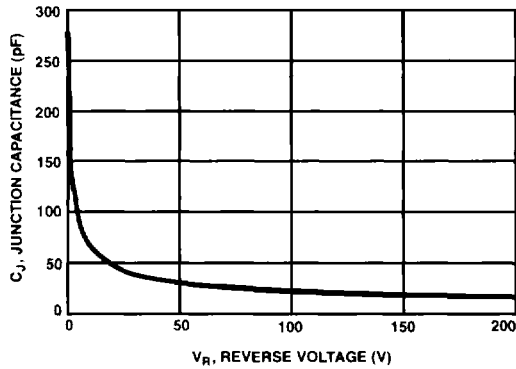

FIGURE 9. TYPICAL JUNCTION CAPACITANCE vs REVERSE VOLTAGE

Test Circuit and Waveforms

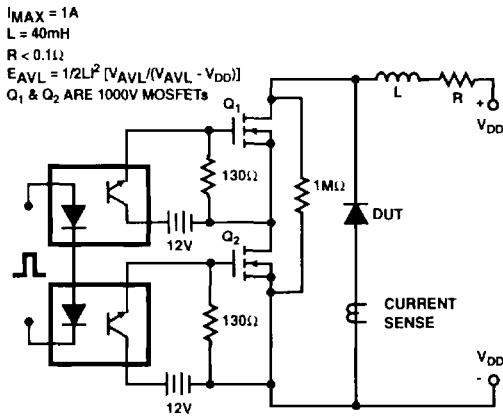

FIGURE 10. AVALANCHE ENERGY TEST CIRCUIT

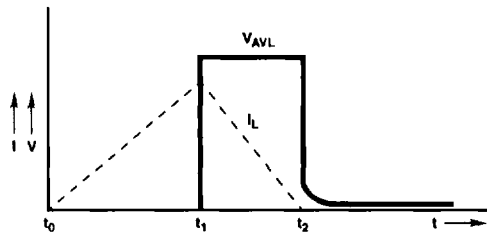

FIGURE 11. AVALANCHE CURRENT AND VOLTAGE WAVEFORMS