

PART NAME: Cable Glands	SCALE: 1:1	DATE: 6/8/17	DR. BY: JD	 DESIGNERS & MANUFACTURERS OF KNUBS, HANDLE, CASES & CUSTOM PLASTIC COMPONENTS	P/N: Cable Gland
THIS DRAWING IS THE PROPERTY OF DAVIES MOLDING COMPANY, IS SUBMITTED SOLELY AS A DESIGN OR ENGINEERING PROJECT WE ACCEPT NO RESPONSIBILITY WHATSOEVER FOR THE PRACTICAL APPLICATION OF THE PIECES MADE TO THIS DESIGN.					

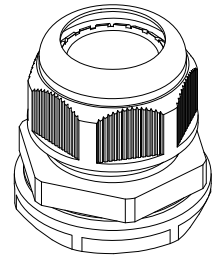
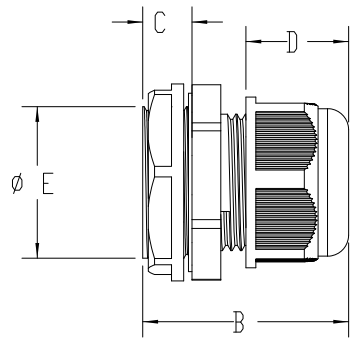
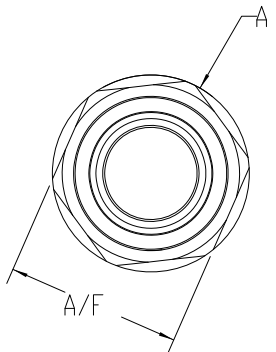

Metric Thread Cable Gland with O-Ring Data sheet

Part #	Threading Type	Cable Range (in mm)	A/F	ø A	B		C	D	ø E	*Panel/Junction Box	
					Min.	Max.				Thickness Range	Hole ø
GC1000-A	M12X1.5	3.5-6.5	15	16.00	27.50	30.50	8.50	12.50	12.00	0.56-1.99	12.50
GC1000-B	M16X1.5	5.5-8	18	20.00	31.00	35.50	8.50	16.50	16.00	0.56-1.99	16.50
GC1000-C	M20X1.5	8-12	24	26.00	32.50	38.00	9.00	17.50	20.00	0.56-1.99	20.50
GC1000-D	M25X1.5	10-14	27	30.00	35.00	40.00	10.00	19.00	25.00	0.56-1.99	25.50
GC1000-E	M32X1.5	14-18	37	40.50	38.00	44.00	10.00	21.50	32.00	0.56-1.99	33.00
GC1000-F	M40X1.5	19-25	45	50.00	47.50	53.50	10.00	26.50	40.00	0.56-1.99	41.00
GC1000-G	M50X1.5	25-32	54	60.50	55.50	64.00	12.50	30.50	50.00	0.56-3.18	51.00
GCL1000-H	M20X1.5	8-12	24	26.00	36.50	41.50	13.00	17.50	20.00	0.56-3.18	20.50
GCL1000-J	M25X1.5	10-14	27	30.00	40.00	44.50	15.00	19.00	25.00	0.56-3.18	25.50

MATERIAL: NYLON 6
 COLOR: BLACK

TOLERANCES: UNLESS OTHERWISE SPECIFIED	DO NOT SCALE DRAWING			
DECIMALS: X.XXX ± .005 X.XX ± .015	MM: X.XX ± 0.15MM X.X ± 0.4MM			
FRACTIONS ± 1/64	ANG. ± 1°	CHANGES		