

AZ DISPLAYS, INC.

COMPLETE LCD SOLUTIONS

SPECIFICATIONS FOR LIQUID CRYSTAL DISPLAY

PART NUMBER:

ACM 0802C SERIES

DATE:

September 15, 1999

ACM0802C SERIES LCD MODULE

1.0 MECHANICAL SPECS

1. Overall Module Size	58.0mm(W) x 32.0mm(H) x max 12.8mm(D) for LED backlight version 58.0mm(W) x 32.0mm(H) x max 8.6mm(D) for reflective version
2. Dot Size	0.56mm(W) x 0.66mm(H)
3. Dot Pitch	0.60mm(W) x 0.70mm(H)
4. Duty	1/16
5. Controller IC	KS0066
6. LC Fluid Options	TN, STN
7. Polarizer Options	Reflective, Transflective, Transmissive
8. Backlight Options	LED
9. Temperature Range Options	Standard (0°C ~ 50°C), Wide(-20°C ~ 70°C)

2.0 ABSOLUTE MAXIMUM RATINGS

Item	Symbol	Min	Typ	Max	Unit
Operating temperature (Standard)	Top	0	-	50	°C
Storage temperature (Standard)	Tst	-20	-	70	°C
Operating temperature (Wide temperature)	Top	-20	-	70	°C
Storage temperature (Wide temperature)	Tst	-30	-	80	°C
Input voltage	Vin	Vss		Vdd	V
Supply voltage for logic	Vdd- Vss	2.7	-	5.5	V
Supply voltage for LCD drive	Vdd- Vo	3.0	4.6	6.5	V

ACM0802C SERIES LCD MODULE

3.0 ELECTRICAL CHARACTERISTICS

Item	Symbol	Condition	Min	Typ	Max	Unit
Input voltage (high)	V_{ih}	H level	2.2	-	V_{dd}	V
Input voltage (low)	V_{il}	L level	0	-	0.6	V
Recommended LC Driving Voltage (Standard Temp)	$V_{dd} - V_o$	0°C	-	4.8	5.4	V
		25°C	4.2	4.6	-	
		50°C	3.9	4.3	-	
Recommended LC Driving Voltage (Wide Temp)	$V_{dd} - V_o$	-20°C	-	6.4	7.2	V
		0°C	-	4.8	-	
		50°C	-	4.3	-	
		70°C	3.7	4.1	-	
Power Supply Current	I_{dd}	$V_{dd}=5.0V$, $f_{osc}=270kHz$	-	0.5	1.0	mA
LED Power Supply Voltage	V_{fled}	$R=6.8\Omega$	-	4.6	5.0	V
LED Power Supply Current	I_{fled}	$R=6.8\Omega$	-	70	175	mA

4.0 OPTICAL CHARACTERISTICS ($T_a=25^\circ C$, $V_{dd}= 5.0V\pm 0.25V$, TN LC fluid)

Item	Symbol	Condition	Min	Typ	Max	Unit
Viewing angle (horizontal)	θ	$C_r \geq 4.0$	-25	-	-	deg
Viewing angle (vertical)	ϕ	$C_r \geq 4.0$	-30	-	30	deg
Contrast Ratio	C_r	$\phi=0^\circ$, $\theta=0^\circ$	-	2	-	
Response time (rise)	T_r	$\phi=0^\circ$, $\theta=0^\circ$	-	120	150	ms
Response time (fall)	T_f	$\phi=0^\circ$, $\theta=0^\circ$	-	120	150	ms

ACM0802C SERIES LCD MODULE

4.1 OPTICAL CHARACTERISTICS (Ta=25°C, Vdd= 5.0V±0.25V, STN LC fluid)

Item	Symbol	Condition	Min	Typ	Max	Unit
Viewing angle (horizontal)	θ	$Cr \geq 2.0$	-60	-	35	deg
Viewing angle (vertical)	ϕ	$Cr \geq 2.0$	-40	-	40	deg
Contrast Ratio	Cr	$\phi=0^\circ, \theta=0^\circ$	-	6	-	
Response time (rise)	Tr	$\phi=0^\circ, \theta=0^\circ$	-	150	250	ms
Response time (fall)	Tf	$\phi=0^\circ, \theta=0^\circ$	-	150	250	ms

5.0 BLOCK DIAGRAM

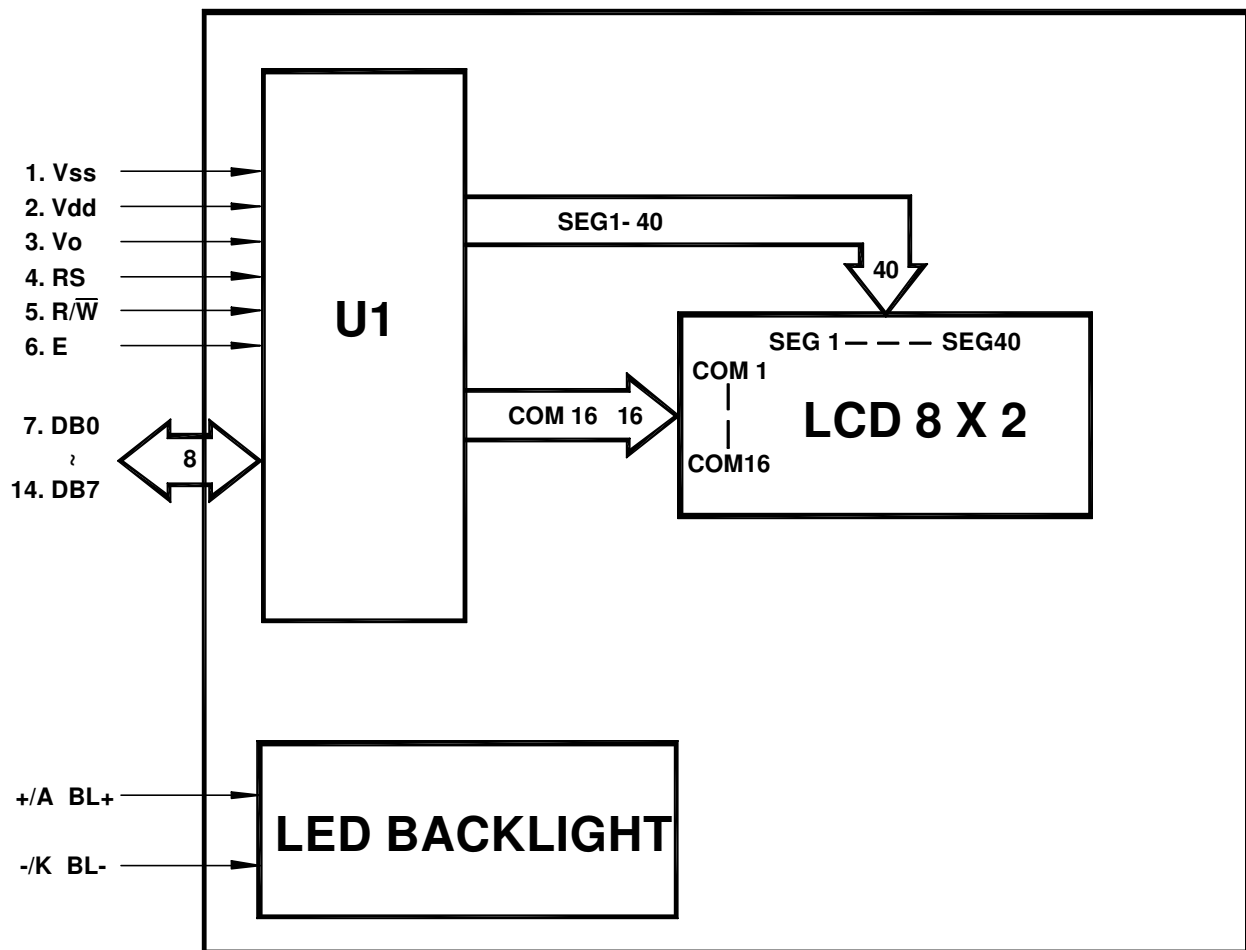

ACM0802C SERIES LCD MODULE

6.0 PIN ASSIGNMENT

Pin No.	Symbol	Function
1	V _{SS}	Ground
2	V _{DD}	+5V
3	V ₀	LCD contrast adjust
4	RS	Register select
5	R/W	Read / write
6	E	Enable
7	DB0	Data bit 0
8	DB1	Data bit 1
9	DB2	Data bit 2
10	DB3	Data bit 3
11	DB4	Data bit 4
12	DB5	Data bit 5
13	DB6	Data bit 6
14	DB7	Data bit 7
+A	BL+	Power Supply for BL+
-K	BL-	Power Supply for BL-

7.0 POWER SUPPLY

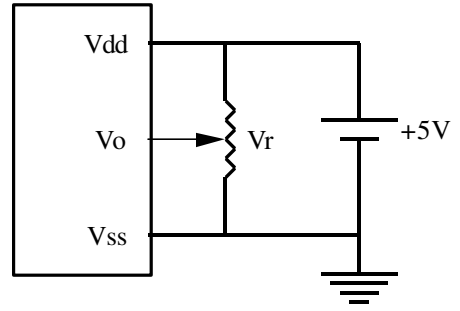

STANDARD TEMP RANGE

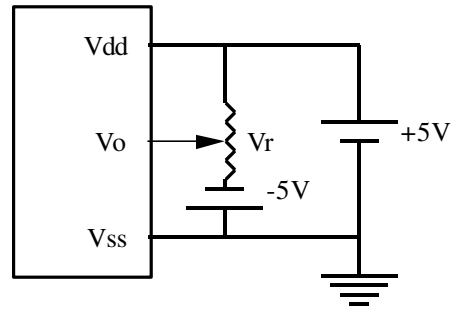

WIDE TEMP RANGE

$$V_R = 10K\Omega \sim 20K\Omega$$

8.0 TIMING CHARACTERISTICS

Item	Symbol	Test Condition	Min.	Typ.	Max.	Unit
Enable cycle time	t_c	Fig. a, Fig. b	500	-	-	ns
Enable pulse width	t_w	Fig. a, Fig. b	220	-	-	ns
Enable rise/fall time	t_r, t_f	Fig. a, Fig. b	-	-	25	ns
RS, R/W set up time	t_{su}	Fig. a, Fig. b	40	-	-	ns
RS, R/W hold time	t_h	Fig. a, Fig. b	10	-	-	ns
Data delay time	t_b	Fig. b	-	-	120	ns
Data set up time	t_{dsu}	Fig. a	60	-	-	ns
Data hold time	t_{dh}	Fig. a, Fig. b	20	-	-	ns

ACM0802C SERIES LCD MODULE

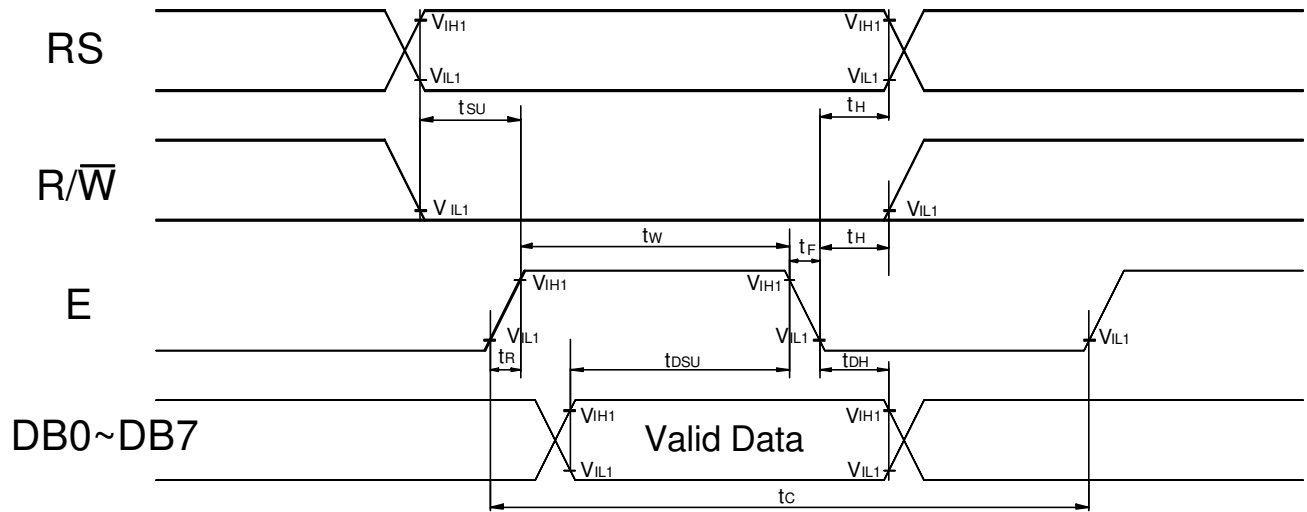

Fig. a Interface timing (data write)

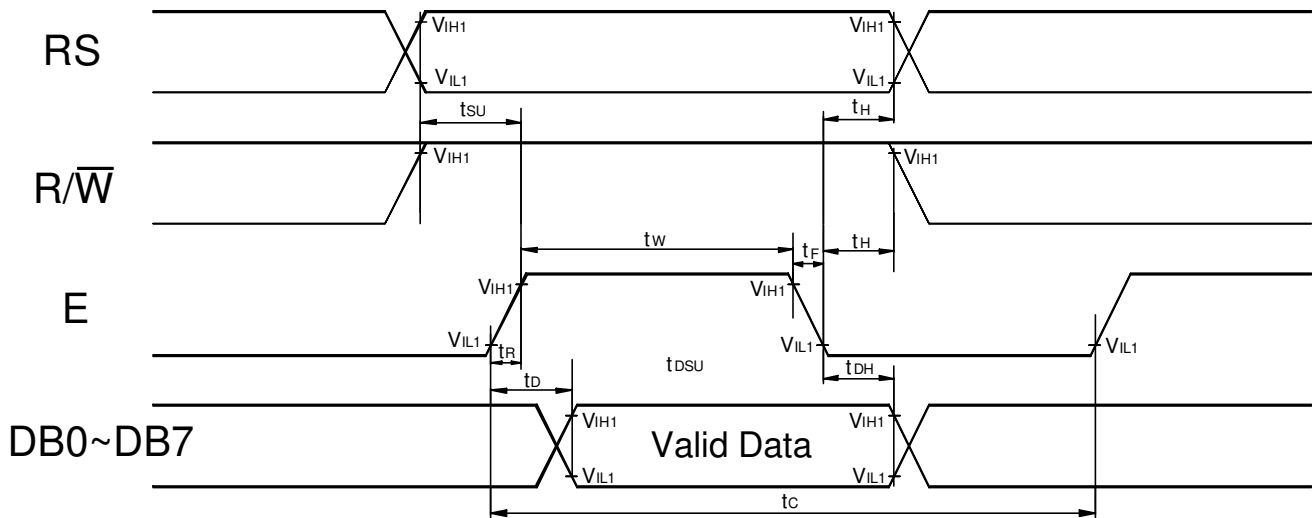
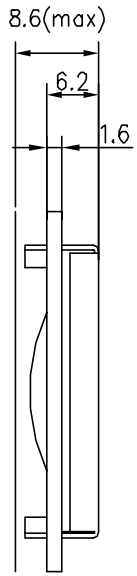

Fig. b Interface timing (data read)

9.0 MECHANICAL DIAGRAM

Without BKL



LED BKL

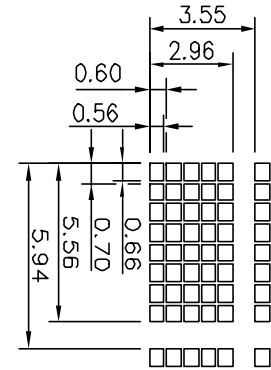
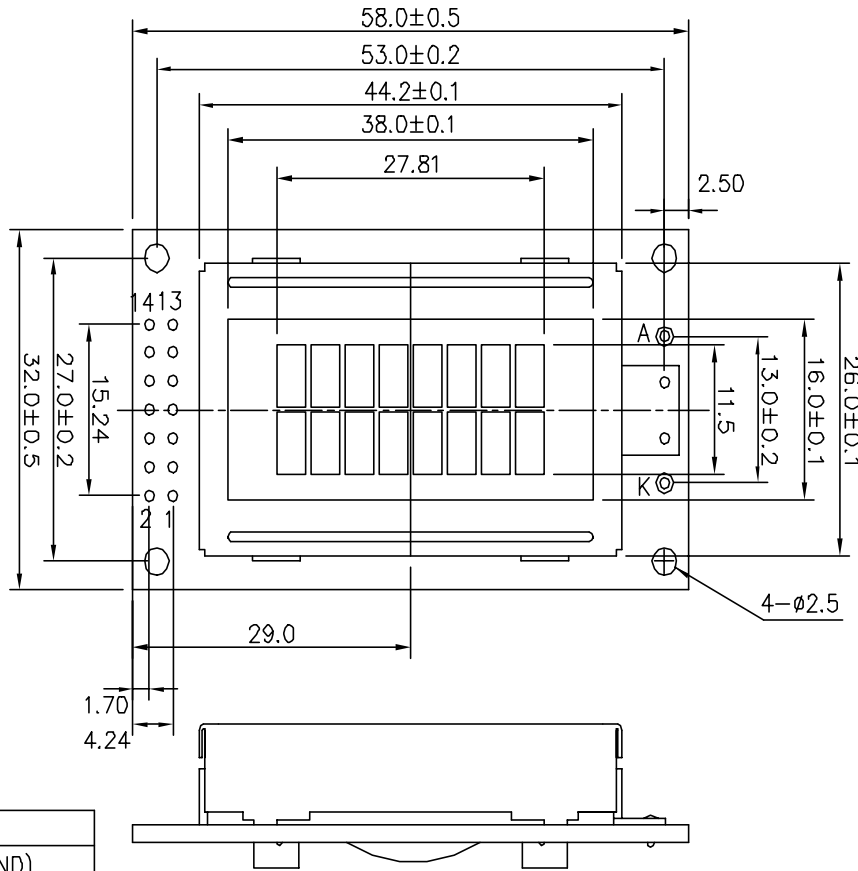
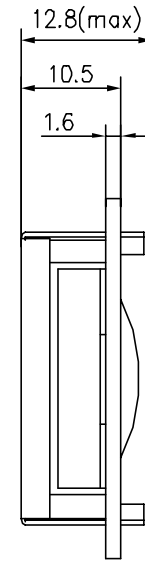

Display Pattern

PIN	SYMBOL	FUNCTION
1	Vss	POWER SUPPLY (GND)
2	Vdd	POWER SUPPLY (+5V)
3	Vo	CONTRAST ADJUST
4	RS	REGISTER SELECT
5	R/W	READ/WRITE SIGNAL
6	E	ENABLE SIGNAL
7	DB0	DATA BUS LINE
8	DB1	
9	DB2	
10	DB3	
11	DB4	
12	DB5	
13	DB6	
14	DB7	
+ / A	BL+	POWER SUPPLY FOR BL+
- / K	BL-	POWER SUPPLY FOR BL-

NOTE:
UNLESS OTHERWISE SPECIFIED STANDARD
TOLERANCE ±0.5MM.

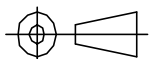
TITLE: ACM0802C SERIES LCD MODULE		AZ DISPLAYS, INC.			
REVISION RECORD		NAME	DATE	DRAWING NO.:	DRAWN BY:
1				ACM0802C-LCM--01	CHECKED BY:
2					APPROVED BY:
3				REVISION:	DATE:
4				VER.2	DATE:
					UNIT: MM SCALE: