



## High Performance Sensorless Motor Control IC

### Description

IRMCK171 is a high performance One Time Programmable ROM based motion control IC designed and optimized for appliance control which contains two computation engines integrated into one monolithic chip. One is the Flexible Motion Control Engine (MCE™) for sensorless control of permanent magnet motors or induction motors; the other is an 8-bit high-speed microcontroller (8051). The user can program a motion control algorithm by connecting these control elements using a graphic compiler. Key components of the complex sensorless control algorithms, such as the Angle Estimator, are provided as complete pre-defined control blocks. A unique analog/digital circuit and algorithm fully supports single shunt or leg shunt current reconstruction. IRMCK171 comes in a 48 pin QFP package.

### Features

- MCE™ (Flexible Motion Control Engine) - Dedicated computation engine for high efficiency sinusoidal sensorless motor control
- Built-in hardware peripheral for single or two shunt current feedback reconstruction and analog circuits
- Supports induction machine and both interior and surface permanent magnet motor sensorless control
- Loss minimization Space Vector PWM
- Two-channel analog output (PWM)
- Embedded 8-bit high speed microcontroller (8051) for flexible I/O and man-machine control
- JTAG programming port for emulation/debugger
- Serial communication interface (UART)
- I2C/SPI serial interface
- Internal 32Kbyte OTP ROM
- 3.3V single supply

### Product Summary

Maximum clock input (fcystal)	60
MHz	
Maximum Internal clock (SYSCLK)	128MHz
Maximum 8051 clock (8051CLK)	32MHz
MCE™ computation data range	16 bit
signed	
8051/MCE Data RAM	2KB
MCE Program RAM	12KB
PWM carrier frequency	20 bits/ SYSCLK
A/D input channels	7
A/D converter resolution	12 bits
A/D converter conversion speed	2 µsec
Analog output (PWM) resolution	8 bits
UART baud rate (typ)	57.6 Kbps
Number of digital I/O (max)	10
Package (lead free)	QFP48
Maximum 3.3V operating current	60mA

Base Part Number	Package Type	Standard Pack		Orderable Part Number
		Form	Quantity	
IRMCK171	QFP	Tray	2500	IRMCK171TY
		Tape and Reel	2000	IRMCK171TR

## Table of Contents

1	Overview .....	5
2	Pinout .....	6
3	IRMCK171 Block Diagram and Main Functions .....	7
4	Application connection and Pin function .....	9
4.1	8051 Peripheral Interface Group .....	10
4.2	Motion Peripheral Interface Group .....	11
4.3	Analog Interface Group .....	11
4.4	Power Interface Group .....	11
4.5	Test Interface Group .....	11
5	DC Characteristics .....	13
5.1	Absolute Maximum Ratings .....	13
5.2	System Clock Frequency and Power Consumption .....	13
5.3	Digital I/O DC Characteristics .....	14
5.4	Analog I/O (IFB+,IFB-,IFBO, AIN5+,AIN5-,AIN5O) DC Characteristics .....	15
5.5	Under Voltage Lockout DC characteristics .....	16
5.6	Itrip comparator DC characteristics .....	16
5.7	CMEXT and AREF Characteristics .....	16
6	AC Characteristics .....	17
6.1	Digital PLL AC Characteristics .....	17
6.2	Analog to Digital Converter AC Characteristics .....	18
6.3	Op amp AC Characteristics .....	19
6.4	SYNC to SVPWM and A/D Conversion AC Timing .....	20
6.5	GATEKILL to SVPWM AC Timing .....	21
6.6	Itrip AC Timing .....	21
6.7	Interrupt AC Timing .....	22
6.8	I <sup>2</sup> C AC Timing .....	22
6.9	SPI AC Timing .....	23
6.10	UART AC Timing .....	25
6.11	CAPTURE Input AC Timing .....	26
6.12	OTP Programming Timing .....	27
6.13	JTAG AC Timing .....	28
7	I/O Structure .....	29
8	Pin List .....	32
9	Package Dimensions .....	34
10	Part Marking Information .....	35
11	Qualification Information .....	35

## List of Tables

Table 1 Absolute Maximum Ratings .....	13
Table 2 System Clock Frequency .....	13
Table 3 Digital I/O DC Characteristics .....	14
Table 5 Analog I/O DC Characteristics .....	15
Table 6 UVcc DC Characteristics .....	16
Table 7 Itrip DC Characteristics .....	16
Table 8 CMEXT and AREF DC Characteristics .....	16
Table 9 PLL AC Characteristics .....	17
Table 10 A/D Converter AC Characteristics .....	18
Table 11 Current Sensing OP Amp AC Characteristics .....	19
Table 12 SYNC AC Characteristics .....	20
Table 13 GATEKILL to SVPWM AC Timing .....	21
Table 14 Itrip AC Timing .....	21
Table 15 Interrupt AC Timing .....	22
Table 16 I <sup>2</sup> C AC Timing .....	22
Table 17 SPI Write AC Timing .....	23
Table 18 SPI Read AC Timing .....	24
Table 19 UART AC Timing .....	25
Table 20 CAPTURE AC Timing .....	26
Table 21 OTP Programming Timing .....	27
Table 22 JTAG AC Timing .....	28
Table 23 Pin List .....	33

## List of Figures

Figure 1 Typical Application Block Diagram Using IRMCK171 .....	5
Figure 2 Pinout of IRMCK171 .....	6
Figure 3 Crystal circuit example.....	17
Figure 4 Voltage droop and S/H hold time.....	18
Figure 5 A capacitor of 47pF is recommended at the output pin of all op amps. ....	19
Figure 6 SYNC timing .....	20
Figure 7 Gatekill timing .....	21
Figure 8 ITRIP timing .....	21
Figure 9 Interrupt timing .....	22
Figure 10 I <sup>2</sup> C Timing .....	22
Figure 11 SPI write timing .....	23
Figure 12 SPI read timing .....	24
Figure 13 UART timing.....	25
Figure 14 CAPTURE timing .....	26
Figure 15 OTP programming timing.....	27
Figure 16 JTAG timing .....	28
Figure 17 PWMUL/PWMUH/PWMVL/PWMVH/PWMWL/PWMWH output.....	29
Figure 18 All digital I/O except motor PWM output.....	29
Figure 19 RESET, GATEKILL I/O.....	30
Figure 20 Analog input.....	30
Figure 21 Analog operational amplifier output and AREF I/O structure.....	30
Figure 22 VPP programming pin I/O structure.....	31
Figure 23 VSS and AVSS pin structure .....	31
Figure 24 VDD1 and VDDCAP pin structure .....	31
Figure 25 XTAL0/XTAL1 pins structure .....	31

## 1 Overview

IRMCK171 is a new generation International Rectifier integrated circuit device primarily designed as a one-chip solution for complete inverter controlled appliance motor control applications. Unlike a traditional microcontroller or DSP, the IRMCK171 provides a built-in closed loop sensorless control algorithm using the unique flexible Motion Control Engine (MCE™) for permanent magnet motors as well as induction motors. The MCE™ consists of a collection of control elements, motion peripherals, a dedicated motion control sequencer and dual port RAM to map internal signal nodes. IRMCK171 also employs a unique single shunt current reconstruction circuit in addition to two leg shunt current sensing circuit to eliminate additional analog/digital circuitry and enables a direct shunt resistor interface to the IC. Motion control programming is achieved using a dedicated graphical compiler integrated into the MATLAB/Simulink™ development environment. Sequencing, user interface, host communication, and upper layer control tasks can be implemented in the 8051 high-speed 8-bit microcontroller. The 8051 microcontroller is equipped with a JTAG port to facilitate emulation and debugging tools. Figure 1 shows a typical application schematic using the IRMCK171.

IRMCK171 contains 32K bytes of OTP program ROM, The IRMCF171 contains 64K bytes of Flash RAM and intended for development purposes only while the IRMCK171 is intended for volume production. Both the development and ROM versions come in a 48-pin QFP package with identical pin configuration to facilitate PC board layout and transition to mass production.

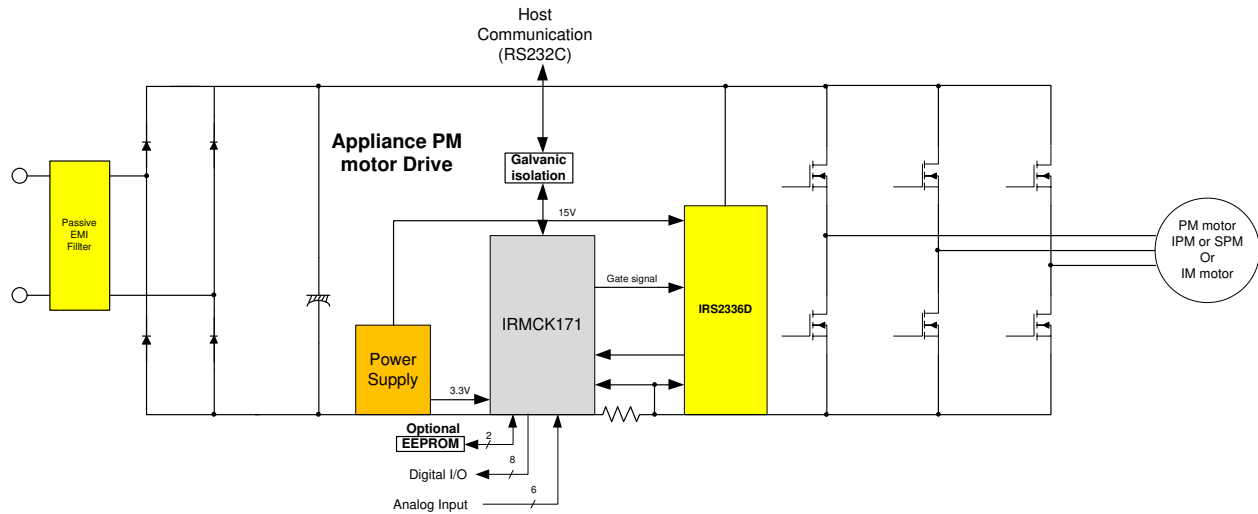

Figure 1 Typical Application Block Diagram Using IRMCK171

## 2 Pinout

Pin out shown is based on QFP48 pin package.

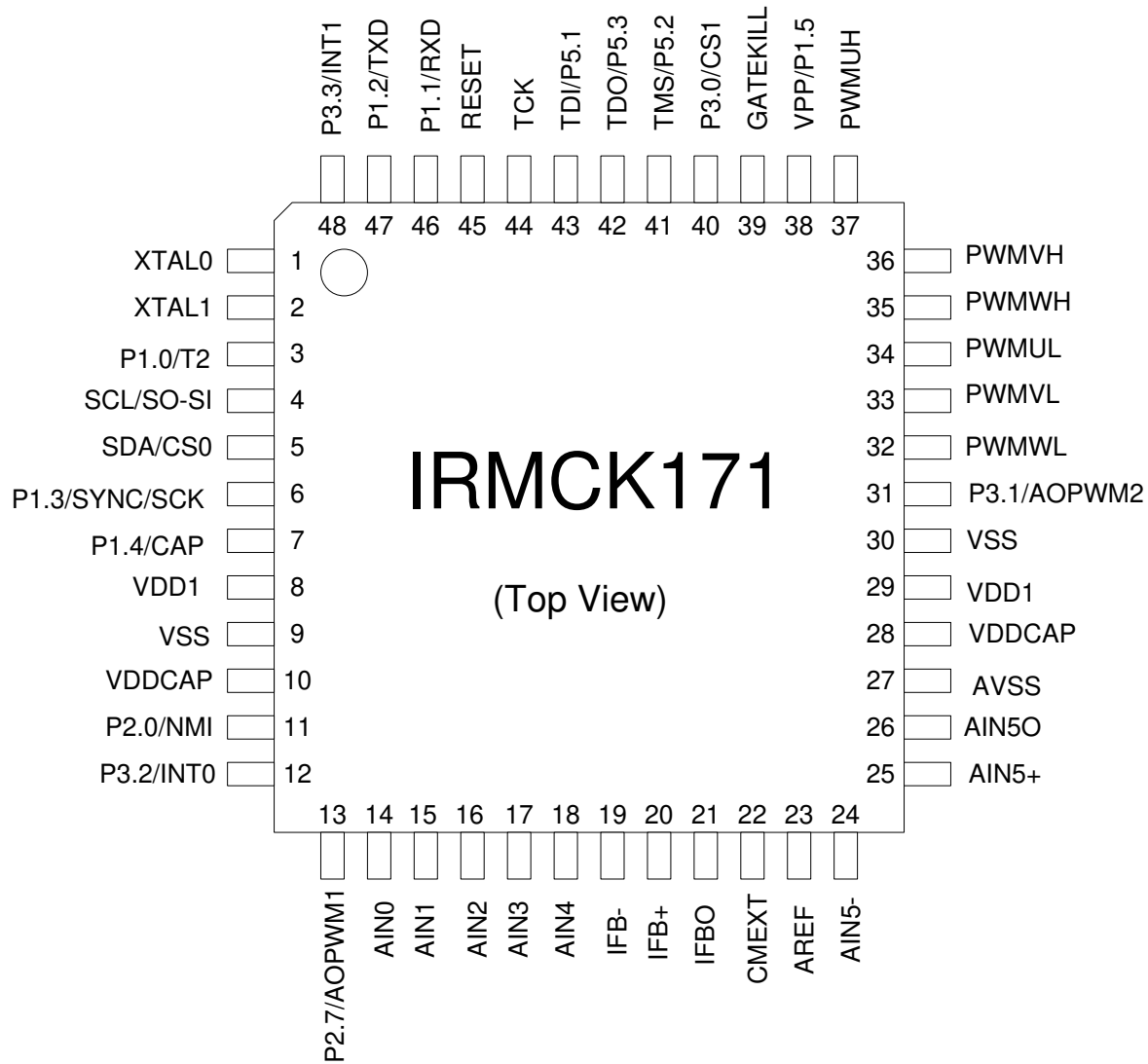
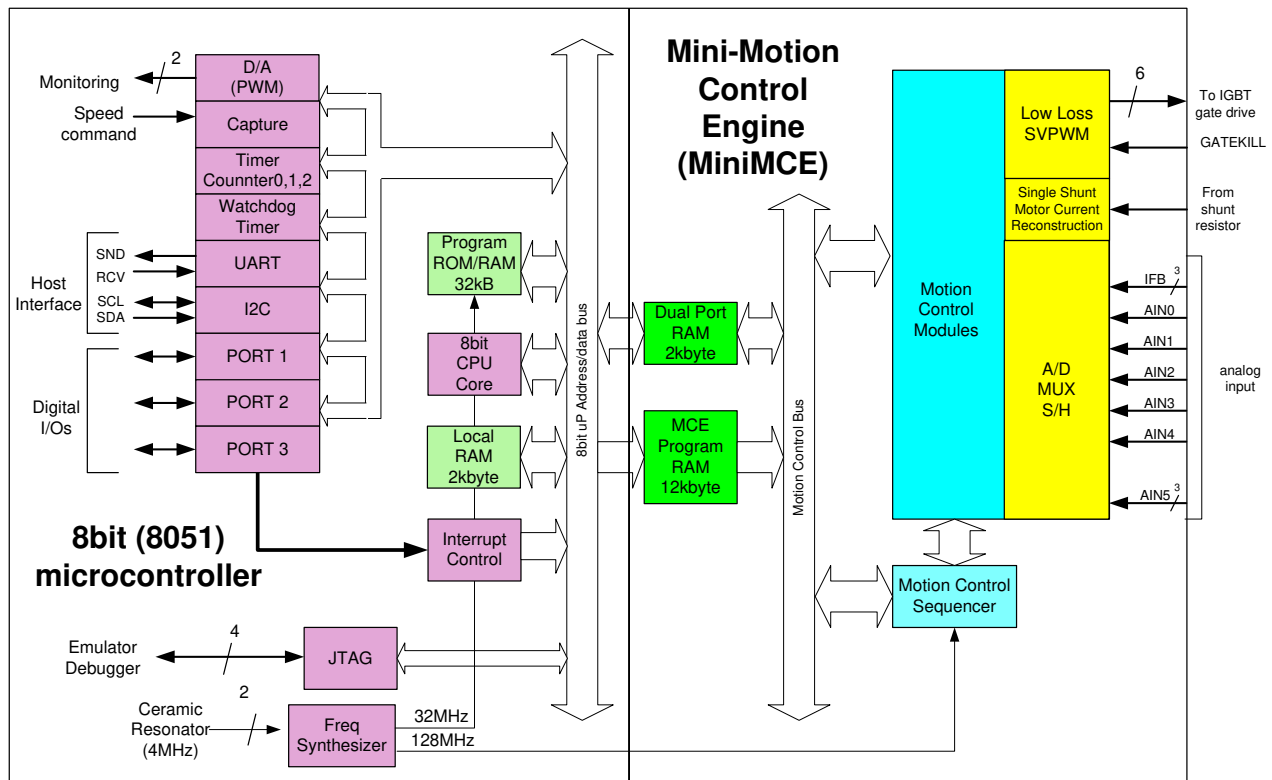

Figure 2 Pinout of IRMCK171

### 3 IRMCK171 Block Diagram and Main Functions

IRMCK171 block diagram is shown in Figure 3.



**Figure 3 IRMCK171 Block Diagram**

IRMCK171 contains the following functions for sensorless AC motor control applications:

- Motion Control Engine (MCE™)
  - Sensorless FOC (complete sensorless field oriented control)
  - Proportional plus Integral block
  - Low pass filter
  - Differentiator and lag (high pass filter)
  - Ramp
  - Limit
  - Angle estimate (sensorless control)
  - Inverse Clark transformation
  - Vector rotator
  - Bit latch
  - Peak detect

- Transition
- Multiply-divide (signed and unsigned)
- Divide (signed and unsigned)
- Adder
- Subtractor
- Comparator
- Counter
- Accumulator
- Switch
- Shift
- ATAN (arc tangent)
- Function block (any curve fitting, nonlinear function)
- 16 bit wide Logic operations (AND, OR, XOR, NOT, NEGATE)
- MCE™ program memory and dual port RAM (max 12K+2k byte)
- MCE™ control sequencer
- 8051 microcontroller
  - Two 16 bit timer/counters
  - One 16 bit periodic timer
  - One 16 bit watchdog timer
  - One 16 bit capture timer
  - Up to 24 discrete I/Os
  - Six-channel 12 bit A/D
    - Buffered (current sensing) one channel (0 – 1.2V input)
    - Unbuffered seven channels (0 – 1.2V input)
  - JTAG port (4 pins)
  - Up to three channels of analog output (8 bit PWM)
  - UART
  - I<sup>2</sup>C/SPI port
  - 32K byte OTP program ROM
  - 2K byte data RAM



## 4 Application connection and Pin function

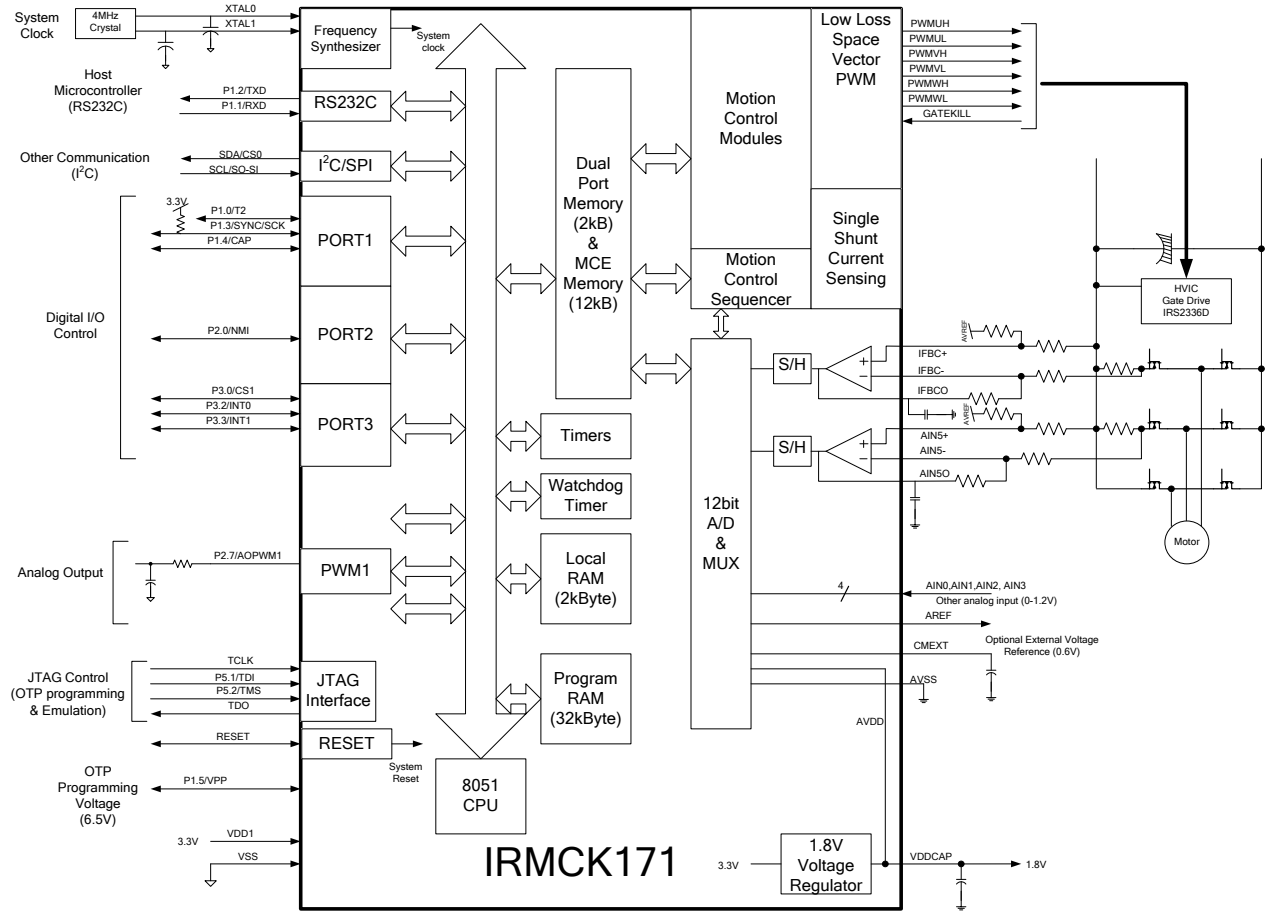

Figure 4 IRMCK171 Connection Diagram

## 4.1 8051 Peripheral Interface Group

### UART Interface

P1.2/TXD	Output, Transmit data from IRMCK171
P1.1/RXD	Input, Receive data to IRMCK171

### Discrete I/O Interface

P1.0/T2	Input/output port 1.0, can be configured as Timer/Counter 2 input
P1.1/RXD	Input/output port 1.1, can be configured as RXD input
P1.2/TXD	Input/output port 1.2, can be configured as TXD output
P1.3/SYNC/SCK	Input/output port 1.3, can be configured as SYNC output or SPI clock output, needs to be pulled up to VDD1 in order to boot from I <sup>2</sup> C EEPROM
P1.4/CAP	Input/output port 1.4, can be configured as Capture Timer input
P1.5/VPP	Input/output port 1.5, or OTP programming voltage
P2.0/NMI	Input/output port 2.0, can be configured as non-maskable interrupt input
P3.2/INT0	Input/output port 3.2, can be configured as INT0 input
P2.7/AOPWM1	Input/output port 2.7, can be configured as AOPWM1 output
P3.0/INT2/CS1	Input/output port 3.0, can be configured as INT2 input or SPI chip select 1
P3.1/AOPWM2	Input/output port 3.1, can be configured as AOPWM2 output
P3.3/INT1	Input/output port 3.3, can be configured as INT1 input
P5.1/TDI	Input port 5.1, configured as JTAG port by default
P5.2/TMS	Input port 5.2, configured as JTAG port by default

### Analog Output Interface

P2.7/AOPWM1	Input/output, can be configured as 8-bit PWM output 1 with programmable carrier frequency
P3.1/AOPWM2	Input/output, can be configured as 8-bit PWM output 2 with programmable carrier frequency

### Crystal Interface

XTAL0	Input, connected to crystal
XTAL1	Output, connected to crystal

### Reset Interface

RESET	Input and Output, system reset, doesn't require external RC time constant
-------	---

### I<sup>2</sup>C Interface

SCL/SO-SI	Output, I <sup>2</sup> C clock output, or SPI data
SDA/CS0	Input/output, I <sup>2</sup> C Data line or SPI chip select 0

### I<sup>2</sup>C/SPI Interface

SCL/SO-SI	Output, I <sup>2</sup> C clock output, or SPI data
SDA/CS0	Input/output, I <sup>2</sup> C data line or SPI chip select 0
P1.3/SYNC/SCK	Input/output port 1.3, can be configured as SYNC output or SPI clock output, needs to be pulled up to VDD1 in order to boot from I <sup>2</sup> C EEPROM
P3.0/INT2/CS1	Input/output port 3.0, can be configured as INT2 input or SPI chip select 1

## 4.2 Motion Peripheral Interface Group

### PWM

PWMUH	Output, PWM phase U high side gate signal, internally pulled down by 58kΩ
PWMUL	Output, PWM phase U low side gate signal, internally pulled down by 58kΩ
PWMVH	Output, PWM phase V high side gate signal, internally pulled down by 58kΩ
PWMVL	Output, PWM phase V low side gate signal, internally pulled down by 58kΩ
PWMWH	Output, PWM phase W high side gate signal, internally pulled down by 58kΩ
PWMWL	Output, PWM phase W low side gate signal, internally pulled down by 58kΩ

### Fault

GATEKILL	Input, upon assertion, this negates all six PWM signals, active low, internally pulled up by 70kΩ
----------	---

## 4.3 Analog Interface Group

AVSS	Analog power return, (analog internal 1.8V power is shared with VDDCAP)
AREF	0.6V buffered output
CMEXT	Unbuffered 0.6V, input to the AREF buffer, capacitor needs to be connected.
IFB+	Input, Operational amplifier positive input for shunt resistor current sensing
IFB-	Input, Operational amplifier negative input for shunt resistor current sensing
IFBO	Output, Operational amplifier output for shunt resistor current sensing
AIN0	Input, Analog input channel 0 (0 – 1.2V), typically configured for DC bus voltage input
AIN1	Input, Analog input channel 1 (0 – 1.2V), needs to be pulled down to AVSS if unused
AIN2	Input, Analog input channel 2 (0 – 1.2V), needs to be pulled down to AVSS if unused
AIN3	Input, Analog input channel 3 (0 – 1.2V), needs to be pulled down to AVSS if unused
AIN4	Input, Analog input channel 4 (0 – 1.2V), needs to be pulled down to AVSS if unused
AIN5+	Input, Operational amplifier positive input for shunt resistor current sensing
AIN5-	Input, Operational amplifier negative input for shunt resistor current sensing
AIN5O	Output, Operational amplifier output for AIN5 output, there is a single sample/hold circuit on the output

## 4.4 Power Interface Group

VDD1	Digital power (3.3V)
VDDCAP	Internal 1.8V output, requires capacitors to the pin. Shared with analog power pad internally <b>Note:</b> The internal 1.8V supply is not designed to power any external circuits or devices. Only capacitors should be connected to this pin.
VSS	Digital common

## 4.5 Test Interface Group

P5.2/TMS	JTAG test mode input or input/output digital port
TDO	JTAG data output
P5.1/TDI	JTAG data input, or input/output digital port

TCK

JTAG test clock

## 5 DC Characteristics

### 5.1 Absolute Maximum Ratings

Symbol	Parameter	Min	Typ	Max	Condition
V <sub>DD1</sub>	Supply Voltage	-0.3 V	-	3.6 V	Respect to VSS
V <sub>IA</sub>	Analog Input Voltage	-0.3 V	-	1.98 V	Respect to AVSS
V <sub>ID</sub>	Digital Input Voltage	-0.3 V	-	6.0 V	Respect to VSS
V <sub>PP</sub>	OTP Programming voltage	-0.3V	-	7.0V	Respect to VSS
T <sub>A</sub>	Ambient Temperature	-40 °C	-	85 °C	
T <sub>S</sub>	Storage Temperature	-65 °C	-	150 °C	

**Table 1 Absolute Maximum Ratings**

**Caution:** Stresses beyond those listed in “Absolute Maximum Ratings” may cause permanent damage to the device. These are stress ratings only and function of the device at these or any other conditions beyond those indicated in the operational sections of the specifications are not implied.

### 5.2 System Clock Frequency and Power Consumption

C<sub>AREF</sub> = 1nF, C<sub>MEXT</sub> = 100nF. VDD1=3.3V, Unless specified, Ta = 25°C.

Symbol	Parameter	Min	Typ	Max	Unit
SYSClk	System Clock	32	-	128	<b>MHz</b>
P <sub>D</sub>	Power consumption		160 <sup>1)</sup>	200	<b>mW</b>

**Table 2 System Clock Frequency**

Note 1) The value is based on the condition of MCE clock=126MHz, 8051 clock 31.5MHz with a actual motor running by a typical MCE application program and 8051 code.

### 5.3 Digital I/O DC Characteristics

Symbol	Parameter	Min	Typ	Max	Condition
$V_{DD1}$	Supply Voltage	3.0 V	3.3 V	3.6 V	Recommended
$V_{PP}$	OTP Programming voltage	6.70V	6.75V	6.80V	Recommended
$V_{IL}$	Input Low Voltage	-0.3 V	-	0.8 V	Recommended
$V_{IH}$	Input High Voltage	2.0 V		3.6 V	Recommended
$C_{IN}$	Input capacitance	-	3.6 pF	-	<sup>(1)</sup>
$I_L$	Input leakage current		$\pm 10$ nA	$\pm 1$ $\mu$ A	$V_O = 3.3$ V or 0 V
$I_{OL1}^{(2)}$	Low level output current	8.9 mA	13.2 mA	15.2 mA	$V_{OL} = 0.4$ V <sup>(1)</sup>
$I_{OH1}^{(2)}$	High level output current	12.4 mA	24.8 mA	38 mA	$V_{OH} = 2.4$ V <sup>(1)</sup>
$I_{OL2}^{(3)}$	Low level output current	17.9 mA	26.3 mA	33.4 mA	$V_{OL} = 0.4$ V <sup>(1)</sup>
$I_{OH2}^{(3)}$	High level output current	24.6 mA	49.5 mA	81 mA	$V_{OH} = 2.4$ V <sup>(1)</sup>

Table 3 Digital I/O DC Characteristics

Note:

- (1) Data guaranteed by design.
- (2) Applied to SCL/SO-SI, SDA/CS0 pins.
- (3) Applied to all digital I/O pins except SCL/SO-SI and SDA/CS0 pins.

#### 5.4 Analog I/O (IFB+,IFB-,IFBO, AIN5+,AIN5-,AIN5O) DC Characteristics

$C_{AREF} = 1\text{nF}$ ,  $C_{MEXT} = 100\text{nF}$ .  $V_{DD1} = 3.3\text{V}$ , Unless specified,  $T_a = 25^\circ\text{C}$ .

Symbol	Parameter	Min	Typ	Max	Condition
$V_{\text{OFFSET}}$	Input Offset Voltage	-	-	26 mV	
$V_I$	Input Voltage Range	0 V		1.2 V	Recommended
$V_{\text{OUTSW}}$	OP amp output operating range	50 mV <sup>(1)</sup>	-	1.2 V	
$C_{\text{IN}}$	Input capacitance	-	3.6 pF	-	<sup>(1)</sup>
$R_{\text{FDBK}}$	OP amp feedback resistor	5 k $\Omega$	-	20 k $\Omega$	Requested between IFBO and IFB-
$OP_{\text{GAINCL}}$	Operating Close loop Gain	80 db	-	-	<sup>(1)</sup>
CMRR	Common Mode Rejection Ratio	-	80 db	-	<sup>(1)</sup>
$I_{\text{SRC}}$	Op amp output source current	-	1 mA	-	$V_{\text{OUT}} = 0.6\text{ V}$ <sup>(1)</sup>
$I_{\text{SNK}}$	Op amp output sink current	-	100 $\mu\text{A}$	-	$V_{\text{OUT}} = 0.6\text{ V}$ <sup>(1)</sup>

Table 4 Analog I/O DC Characteristics

Note:

(1) Data guaranteed by design.

## 5.5 Under Voltage Lockout DC characteristics

Unless specified, Ta = 25°C.

Symbol	Parameter	Min	Typ	Max	Condition
UV <sub>CC+</sub>	UV <sub>CC</sub> positive going Threshold	2.78 V	3.04 V	3.23 V	(1)
UV <sub>CC-</sub>	UV <sub>CC</sub> negative going Threshold	2.78 V	2.97 V	3.23 V	
UV <sub>CCH</sub>	UV <sub>CC</sub> Hysteresys	-	73 mV	-	(1)

Table 5 UV<sub>CC</sub> DC Characteristics

Note:

(1) Data guaranteed by design.

## 5.6 Itrip comparator DC characteristics

Unless specified, VDD1=3.3V, Ta = 25°C.

Symbol	Parameter	Min	Typ	Max	Condition
Itrip <sub>+</sub>	Itrip positive going Threshold	-	1.22V	-	
Itrip <sub>-</sub>	Itrip negative going Threshold	-	1.10V	-	
ItripH	Itrip Hysteresys	-	120mV	-	

Table 6 Itrip DC Characteristics

## 5.7 CMEXT and AREF Characteristics

C<sub>AREF</sub> = 1nF, C<sub>CMEXT</sub> = 100nF. Unless specified, Ta = 25°C.

Symbol	Parameter	Min	Typ	Max	Condition
V <sub>CM</sub>	CMEXT voltage	495 mV	600 mV	700 mV	VDD1 = 3.3 V <sup>(1)</sup>
V <sub>AREF</sub>	Buffer Output Voltage	495 mV	600 mV	700 mV	VDD1 = 3.3 V
ΔV <sub>o</sub>	Load regulation (V <sub>DC</sub> -0.6)	-	1 mV	-	(1)
PSRR	Power Supply Rejection Ratio	-	75 db	-	(1)

Table 7 CMEXT and AREF DC Characteristics

Note:

(1) Data guaranteed by design.



## 6 AC Characteristics

### 6.1 Digital PLL AC Characteristics

Symbol	Parameter	Min	Typ	Max	Condition
F <sub>CLKIN</sub>	Crystal input frequency	3.2 MHz	4 MHz	60 MHz	(1) (see figure below)
F <sub>PLL</sub>	Internal clock frequency	32 MHz	50 MHz	128 MHz	(1)
F <sub>LWPW</sub>	Sleep mode output frequency	F <sub>CLKIN</sub> ÷ 256	-	-	(1)
J <sub>S</sub>	Short time jitter	-	200 psec	-	(1)
D	Duty cycle	-	50 %	-	(1)
T <sub>LOCK</sub>	PLL lock time	-	-	500 μsec	(1)

**Table 8 PLL AC Characteristics**

Note:

(1) Data guaranteed by design.

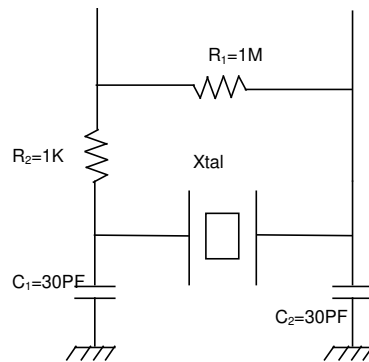

**Figure 3 Crystal circuit example**

## 6.2 Analog to Digital Converter AC Characteristics

Unless specified,  $T_a = 25^\circ\text{C}$ .

Symbol	Parameter	Min	Typ	Max	Condition
$T_{\text{CONV}}$	Conversion time	-	-	2.05 $\mu\text{sec}$	<sup>(1)</sup>
$T_{\text{HOLD}}$	Sample/Hold maximum hold time	-	-	10 $\mu\text{sec}$	Voltage droop $\leq 15$ LSB (see figure below)

**Table 9 A/D Converter AC Characteristics**

Note:

(1) Data guaranteed by design.

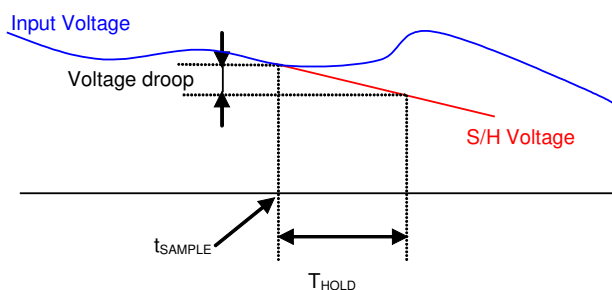

**Figure 4 Voltage droop and S/H hold time**

### 6.3 Op amp AC Characteristics

Unless specified, Ta = 25°C.

Symbol	Parameter	Min	Typ	Max	Condition
OP <sub>SR</sub>	OP amp slew rate	-	10 V/μsec	-	VDD1 = 3.3 V, CL = 33 pF <sup>(1)</sup>
OP <sub>IMP</sub>	OP input impedance	-	10 <sup>8</sup> Ω	-	<sup>(1)</sup> <sup>(2)</sup>
T <sub>SET</sub>	Settling time	-	400 ns	-	VDD1 = 3.3 V, CL = 33 pF <sup>(1)</sup>

Table 10 Current Sensing OP Amp AC Characteristics

Note:

(1) Data guaranteed by design.

(2) To guarantee stability of the operational amplifier, it is recommended to load the output pin by a capacitor of 47pF, see Figure 5. Here only the single shunt current amplifier is show but all op amp outputs should be loaded with this capacitor.

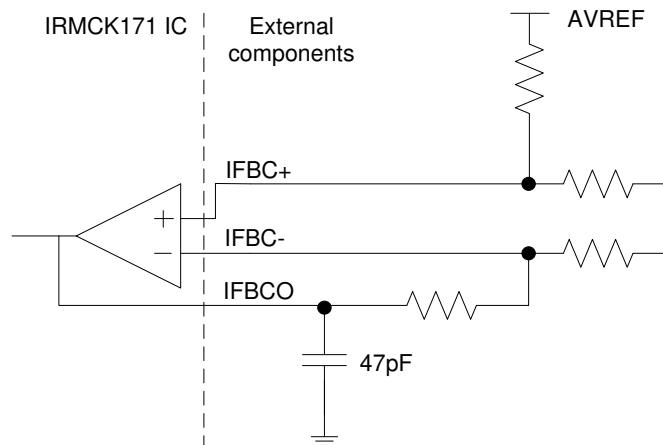
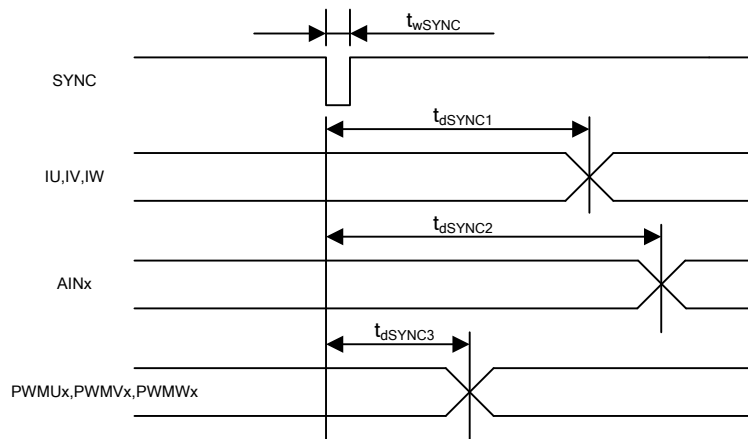

Figure 5 A capacitor of 47pF is recommended at the output pin of all op amps.

## 6.4 SYNC to SVPWM and A/D Conversion AC Timing



**Figure 6 SYNC timing**

Unless specified, Ta = 25°C.

Symbol	Parameter	Min	Typ	Max	Unit
$t_{w\text{SYNC}}$	SYNC pulse width	-	32	-	SYSCCLK
$t_{d\text{SYNC}1}$	SYNC to current feedback conversion time	-	-	100	SYSCCLK
$t_{d\text{SYNC}2}$	SYNC to AIN0-5 analog input conversion time	-	-	200	SYSCCLK <sup>(1)</sup>
$t_{d\text{SYNC}3}$	SYNC to PWM output delay time	-	-	2	SYSCCLK

**Table 11 SYNC AC Characteristics**

Note:

(1) AIN1 through AIN5 channels are converted once every 6 SYNC events

## 6.5 GATEKILL to SVPWM AC Timing

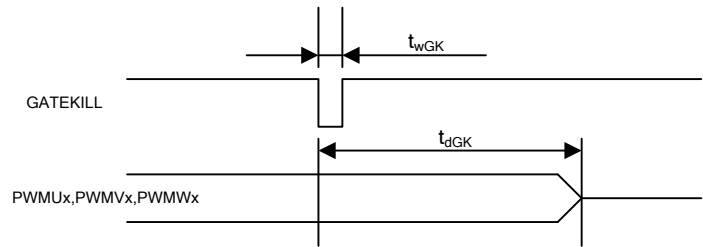

Figure 7 Gatekill timing

Unless specified, Ta = 25°C.

Symbol	Parameter	Min	Typ	Max	Unit
$t_{wGK}$	GATEKILL pulse width	32	-	-	SYCLK
$t_{dGK}$	GATEKILL to PWM output delay	-	-	100	SYCLK

Table 12 GATEKILL to SVPWM AC Timing

## 6.6 Itrip AC Timing

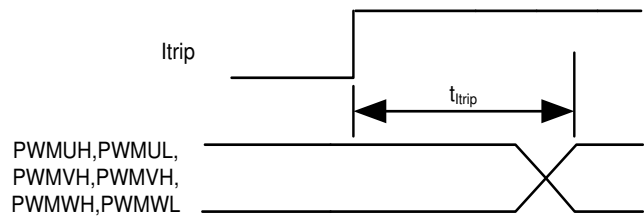

Figure 8 ITRIP timing

Unless specified, Ta = 25°C.

Symbol	Parameter	Min	Typ	Max	Unit
$t_{ITRIP}$	Itrip propagation delay	-	-	100(sysclk)+1.0usec	SYCLK+usec

Table 13 Itrip AC Timing

## 6.7 Interrupt AC Timing

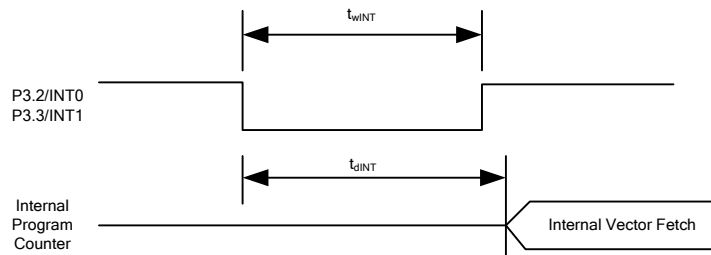

Figure 9 Interrupt timing

Unless specified,  $T_a = 25^\circ\text{C}$ .

Symbol	Parameter	Min	Typ	Max	Unit
$t_{wINT}$	INT0, INT1 Interrupt Assertion Time	4	-	-	SYSCCLK
$t_{dINT}$	INT0, INT1 latency	-	-	4	SYSCCLK

Table 14 Interrupt AC Timing

## 6.8 I<sup>2</sup>C AC Timing

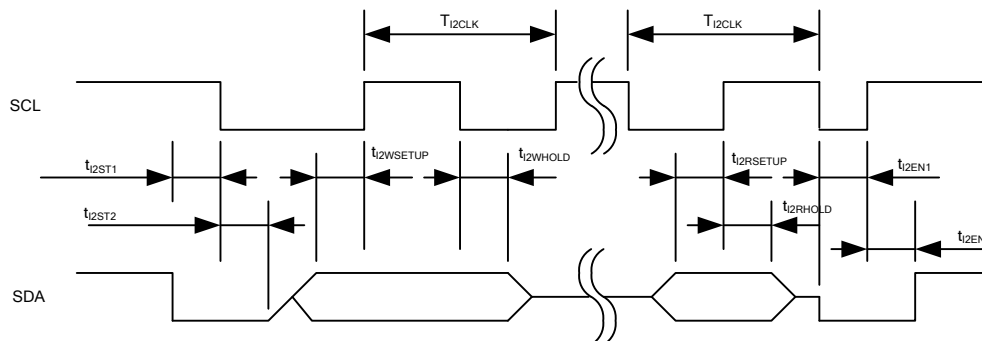

Figure 10 I<sup>2</sup>C Timing

Unless specified,  $T_a = 25^\circ\text{C}$ .

Symbol	Parameter	Min	Typ	Max	Unit
$T_{I2CLK}$	I <sup>2</sup> C clock period	10	-	8192	SYSCCLK
$t_{I2ST1}$	I <sup>2</sup> C SDA start time	0.25	-	-	$T_{I2CLK}$
$t_{I2ST2}$	I <sup>2</sup> C SCL start time	0.25	-	-	$T_{I2CLK}$
$t_{I2WSETUP}$	I <sup>2</sup> C write setup time	0.25	-	-	$T_{I2CLK}$
$t_{I2WHOLD}$	I <sup>2</sup> C write hold time	0.25	-	-	$T_{I2CLK}$
$t_{I2RSETUP}$	I <sup>2</sup> C read setup time	I <sup>2</sup> C filter time <sup>(1)</sup>	-	-	SYSCCLK
$t_{I2RHOLD}$	I <sup>2</sup> C read hold time	1	-	-	SYSCCLK

Table 15 I<sup>2</sup>C AC Timing

Note:

(1) I<sup>2</sup>C read setup time is determined by the programmable filter time applied to I<sup>2</sup>C communication.

## 6.9 SPI AC Timing

### SPI Write AC timing

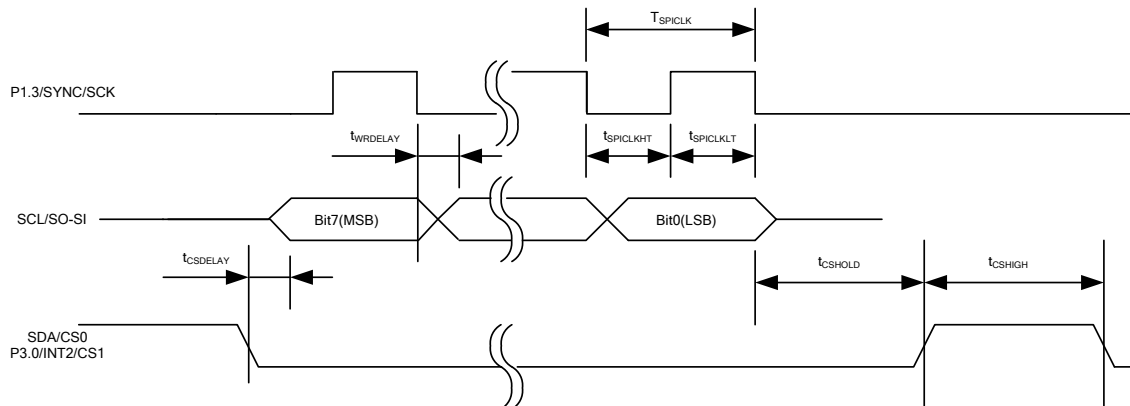
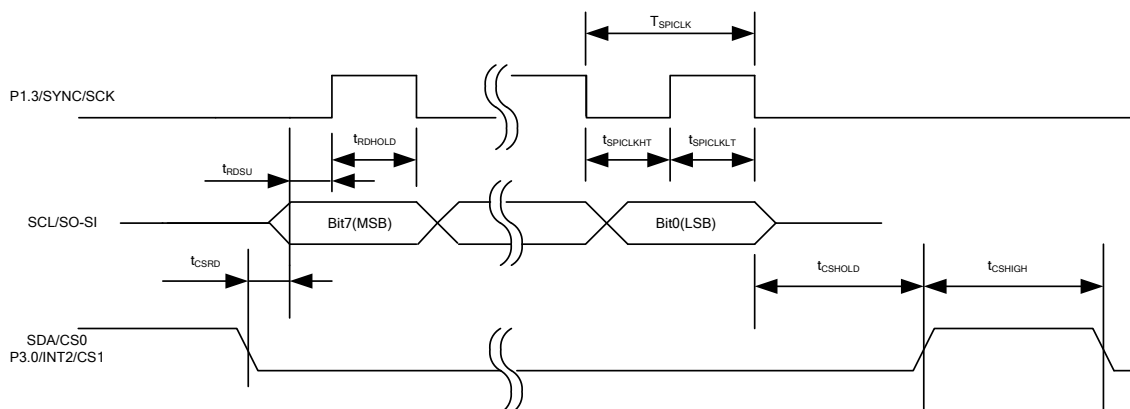

Figure 11 SPI write timing

Unless specified,  $T_a = 25^\circ\text{C}$ .

Symbol	Parameter	Min	Typ	Max	Unit
$T_{\text{SPICLK}}$	SPI clock period	4	-	-	SYSClk
$t_{\text{SPICLKHT}}$	SPI clock high time	-	1/2	-	$T_{\text{SPICLK}}$
$t_{\text{SPICLKLT}}$	SPI clock low time	-	1/2	-	$T_{\text{SPICLK}}$
$t_{\text{CSDELAY}}$	CS to data delay time	-	-	10	nsec
$t_{\text{WRDELAY}}$	CLK falling edge to data delay time	-	-	10	nsec
$t_{\text{CSHIGH}}$	CS high time between two consecutive byte transfer	1	-	-	$T_{\text{SPICLK}}$
$t_{\text{CSHOLD}}$	CS hold time	-	1	-	$T_{\text{SPICLK}}$

Table 16 SPI Write AC Timing

**SPI Read AC Timing**

**Figure 12 SPI read timing**

 Unless specified,  $T_a = 25^\circ\text{C}$ .

Symbol	Parameter	Min	Typ	Max	Unit
$T_{\text{SPICLK}}$	SPI clock period	4	-	-	SYSCLK
$t_{\text{SPICLKHT}}$	SPI clock high time	-	1/2	-	$T_{\text{SPICLK}}$
$t_{\text{SPICLKLT}}$	SPI clock low time	-	1/2	-	$T_{\text{SPICLK}}$
$t_{\text{CSRd}}$	CS to data delay time	-	-	10	nsec
$t_{\text{RDSU}}$	SPI read data setup time	10	-	-	nsec
$t_{\text{RDHOLD}}$	SPI read data hold time	10	-	-	nsec
$t_{\text{CSHIGH}}$	CS high time between two consecutive byte transfer	1	-	-	$T_{\text{SPICLK}}$
$t_{\text{CSHOLD}}$	CS hold time	-	1	-	$T_{\text{SPICLK}}$

**Table 17 SPI Read AC Timing**



### 6.10 UART AC Timing

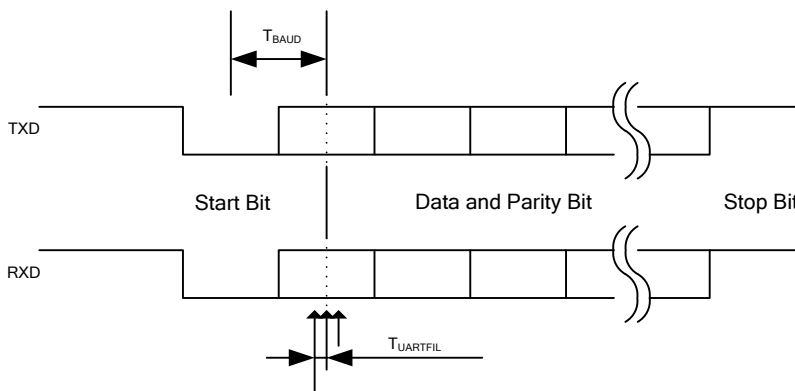

**Figure 13 UART timing**

Unless specified, Ta = 25°C.

Symbol	Parameter	Min	Typ	Max	Unit
T <sub>BAUD</sub>	Baud Rate Period	-	57600	-	bit/sec
T <sub>UARTFIL</sub>	UART sampling filter period <sup>(1)</sup>	-	1/16	-	T <sub>BAUD</sub>

**Table 18 UART AC Timing**

Note:

- (1) Each bit including start and stop bit is sampled three times at center of a bit at an interval of 1/16 T<sub>BAUD</sub>. If three sampled values do not agree, then UART noise error is generated.

### 6.11 CAPTURE Input AC Timing

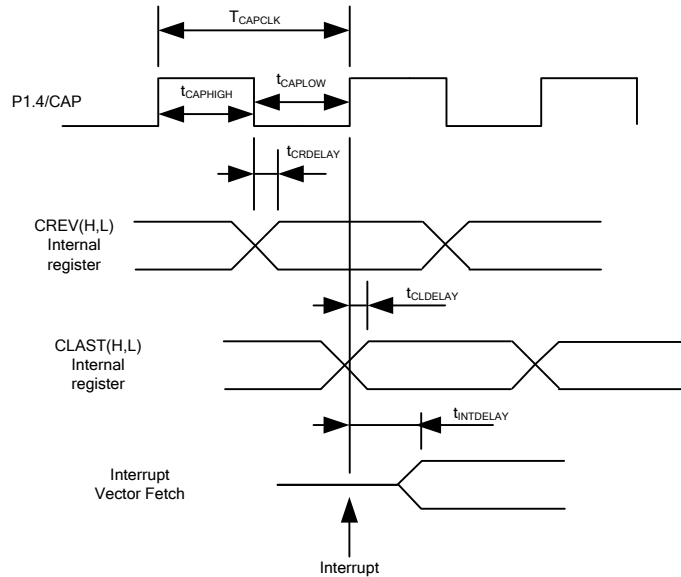

Figure 14 CAPTURE timing

Unless specified,  $T_a = 25^\circ\text{C}$ .

Symbol	Parameter	Min	Typ	Max	Unit
$T_{CAPCLK}$	CAPTURE input period	8	-	-	SYCLK
$t_{CAPHIGH}$	CAPTURE input high time	4	-	-	SYCLK
$t_{CAPLOW}$	CAPTURE input low time	4	-	-	SYCLK
$t_{CRDELAY}$	CAPTURE falling edge to capture register latch time	-	-	4	SYCLK
$t_{CLDELAY}$	CAPTURE rising edge to capture register latch time	-	-	4	SYCLK
$t_{INTDELAY}$	CAPTURE input interrupt latency time	-	-	4	SYCLK

Table 19 CAPTURE AC Timing

## 6.12 OTP Programming Timing

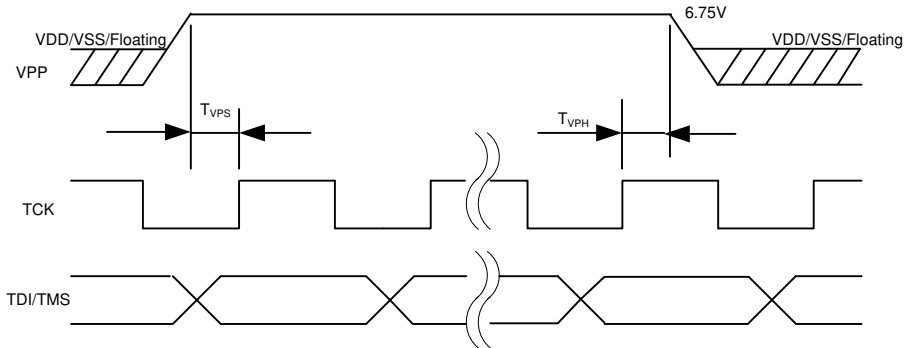

Figure 15 OTP programming timing

Unless specified,  $T_a = 25^\circ\text{C}$ .

Symbol	Parameter	Min	Typ	Max	Unit
$T_{VPS}$	VPP Setup Time	10	-	-	nsec
$T_{VPH}$	VPP Hold Time	15	-	-	nsec

Table 20 OTP Programming Timing

### 6.13 JTAG AC Timing

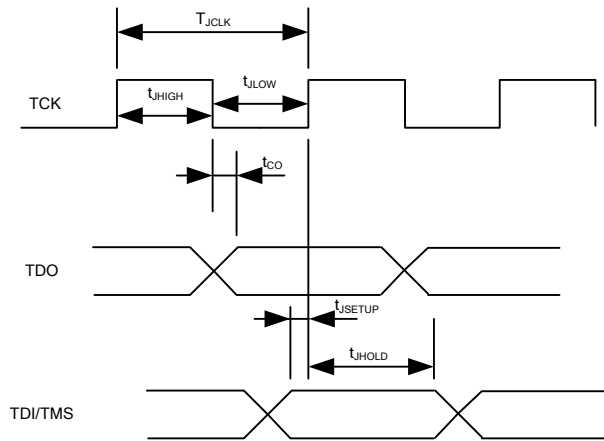

**Figure 16 JTAG timing**

Unless specified,  $T_a = 25^\circ\text{C}$ .

Symbol	Parameter	Min	Typ	Max	Unit
$T_{JCLK}$	TCK Period	-	-	50	MHz
$t_{JHIGH}$	TCK High Period	10	-	-	nsec
$t_{JLOW}$	TCK Low Period	10	-	-	nsec
$t_{CO}$	TCK to TDO propagation delay time	0	-	5	nsec
$t_{SETUP}$	TDI/TMS setup time	4	-	-	nsec
$t_{HOLD}$	TDI/TMS hold time	0	-	-	nsec

**Table 21 JTAG AC Timing**

## 7 I/O Structure

The following figure shows the motor PWM output (PWMUH/PWMUL/PWMVH/PWMVL/PWMWH/PWMWL)

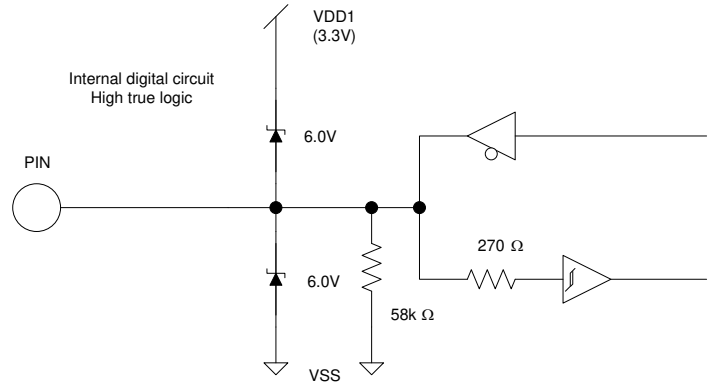

Figure 17 PWMUL/PWMUH/PWMVL/PWMVH/PWMWL/PWMWH output

The following figure shows the digital I/O structure except the motor PWM output

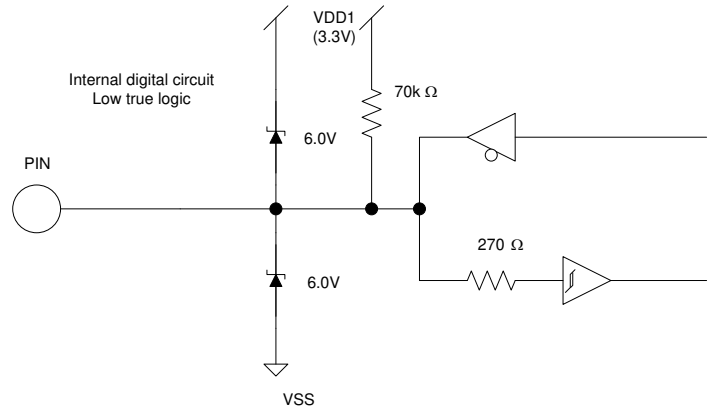
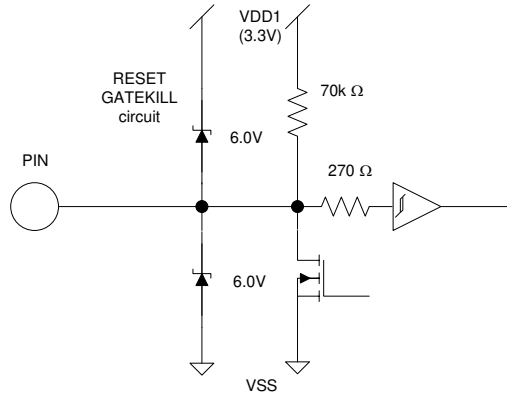

Figure 18 All digital I/O except motor PWM output

The following figure shows RESET and GATEKILL I/O structure.



**Figure 19 RESET, GATEKILL I/O**

The following figure shows the analog input structure.

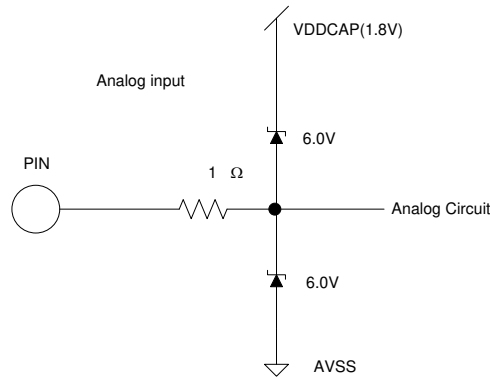

**Figure 20 Analog input**

The following figure shows all analog operational amplifier output pins and AREF pin I/O structure.

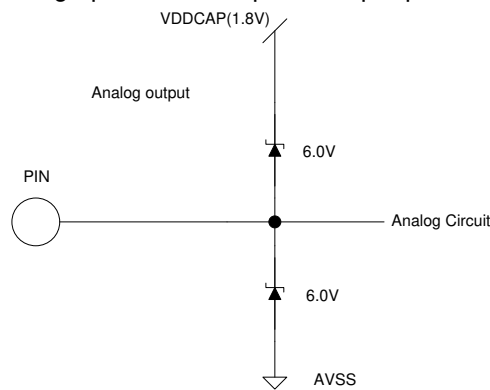

**Figure 21 Analog operational amplifier output and AREF I/O structure**

The following figure shows the VPP pin structure

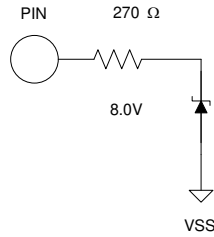

**Figure 22 VPP programming pin I/O structure**

The following figure shows the VSS and AVSS pins structure

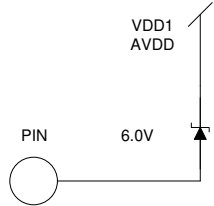

**Figure 23 VSS and AVSS pin structure**

The following figure shows the VDD1 and VDDCAP pin structure

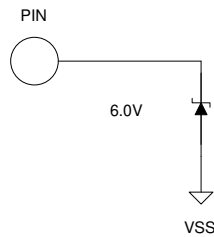

**Figure 24 VDD1 and VDDCAP pin structure**

The following figure shows the XTAL0 and XTAL1 pins structure

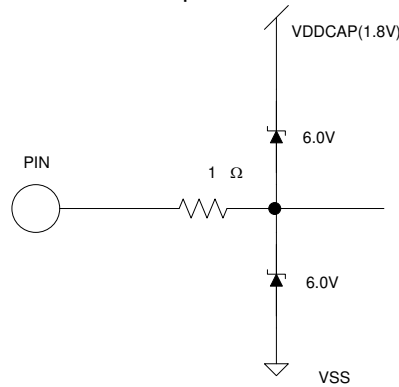

**Figure 25 XTAL0/XTAL1 pins structure**

## 8 Pin List

Pin Number	Pin Name	Internal Pull-up /Pull-down	Pin Type	Description
1	XTAL0		I	Crystal input
2	XTAL1		O	Crystal output
3	P1.0/T2		I/O	Discrete programmable I/O or Timer/Counter 2 input
4	SCL/SO-SI		I/O	I <sup>2</sup> C clock output (open drain, need pull up) or SPI data
5	SDA/CS0		I/O	I <sup>2</sup> C data (open drain, need pull up) or SPI Chip Select 0
6	P1.3/SYNC/SCK		I/O	Discrete programmable I/O or SYNC output or SPI clock output, needs to be pulled up to VDD1 in order to boot from I <sup>2</sup> C EEPROM
7	P1.4/CAP		I/O	Discrete programmable I/O or Capture timer input
8	VDD1		P	3.3V digital power
9	VSS		P	Digital common
10	VDDCAP		P	Internal 1.8V output, Capacitor(s) to be connected
11	P2.0/NMI		I/O	Discrete programmable I/O or Non-maskable Interrupt input
12	P3.2/INT0		I/O	Discrete programmable I/O or Interrupt 0 input
13	P2.7/AOPWM1		I/O	Discrete programmable I/O or PWM 1 digital output
14	AIN0		I	Analog input channel 0, 0-1.2V range, needs to be pulled down to AVSS if unused
15	AIN1		I	Analog input channel 1, 0-1.2V range, needs to be pulled down to AVSS if unused
16	AIN2		I	Analog input channel 2, 0-1.2V range, needs to be pulled down to AVSS if unused
17	AIN3		I	Analog input channel 3, 0-1.2V range, needs to be pulled down to AVSS if unused
18	AIN4		I	Analog input channel 4, 0-1.2V range, needs to be pulled down to AVSS if unused
19	IFB-		I	Single shunt current sensing OP amp input (-)
20	IFB+		I	Single shunt current sensing OP amp input (+)
21	IFBO		O	Single shunt current sensing OP amp output
22	CMEXT		O	Unbuffered 0.6V output. Capacitor needs to be connected.
23	AREF		O	Analog reference voltage output (0.6V)
24	AIN5-		I	Analog input channel 5, 0-1.2V range, needs to be pulled down to AVSS if unused
25	AIN5+		I	Analog input channel 5, 0-1.2V range, needs to be pulled down to AVSS if unused
26	AIN5O		O	Analog output 5, 0-1.2V range,
27	AVSS		P	Analog common
28	VDDCAP		P	Internal 1.8V output, Capacitor(s) to be connected
29	VDD1		P	3.3V digital power
30	VSS		P	Digital common
31	P3.1/AOPWM2		I/O	Discrete programmable I/O or PWM 2 digital output



Pin Number	Pin Name	Internal Pull-up /Pull-down	Pin Type	Description
32	PWMWL	58 kΩ Pull down	O	PWM gate drive for phase W low side, configurable either high or low true.
33	PWMVL	58 kΩ Pull down	O	PWM gate drive for phase V low side, configurable either high or low true
34	PWMUL	58 kΩ Pull down	O	PWM gate drive for phase U low side, configurable either high or low true
35	PWMWH	58 kΩ Pull down	O	PWM gate drive for phase W high side, configurable either high or low true
36	PWMVH	58 kΩ Pull down	O	PWM gate drive for phase V high side, configurable either high or low true
37	PWMUH	58 kΩ Pull down	O	PWM gate drive for phase U high side, configurable either high or low true
38	P1.5/VPP		I/O P	OTP programming power (6.5V) or Discrete programmable I/O.
39	GATEKILL	70 kΩ Pull up	I	PWM shutdown input, 2-μsec digital filter, configurable either high or low true.
40	P3.0/INT2/CS1	70 kΩ Pull up	I/O	Discrete programmable I/O or external interrupt 2 input or SPI Chip Select 1
41	P5.2/TMS		I/O	JTAG test mode select or Discrete I/O
42	TDO		O	JTAG test data output
43	P5.1/TDI		I/O	JTAG test data input or Discrete I/O
44	TCK		I	JTAG test clock
45	RESET		I/O	Reset, low true, Schmitt trigger input
46	P1.1/RXD		I/O	UART receiver input or Discrete programmable I/O
47	P1.1/RXD		I/O	UART transmitter output or Discrete programmable I/O
48	P3.3/INT1		I/O	Interrupt 1 input or Discrete I/O

**Table 22 Pin List**

## 9 Package Dimensions

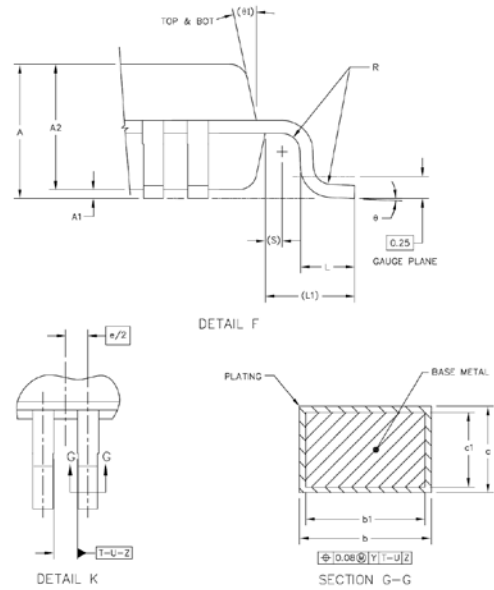
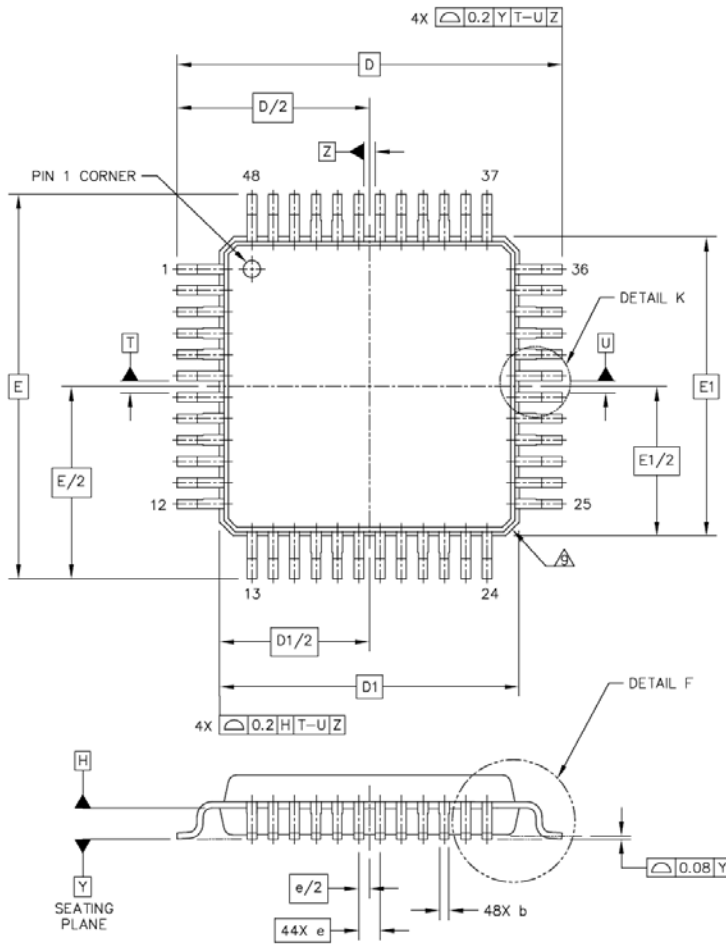
**NOTES:**

1. DIMENSIONS ARE IN MILLIMETERS.
  2. INTERPRET DIMENSIONS AND TOLERANCES PER ASME Y14.5M-1994.
  3. DATUM PLANE H IS LOCATED AT BOTTOM OF LEAD AND IS CONCORDANT WITH THE LEAD WHERE THE LEAD EXITS THE PLASTIC BODY AT THE BOTTOM OF THE PARTING LINE.
  4. DATUM T, U AND Z TO BE DETERMINED AT DATUM PLANE H.
  5. DIMENSIONS D AND E TO BE DETERMINED AT SEATING PLANE Y.
  6. DIMENSIONS D1 AND E1 DO NOT INCLUDE MOLD PROTRUSION. ALLOWABLE PROTRUSION IS 0.25 PER SIDE. DIMENSIONS D1 AND E1 DO INCLUDE MOLD MISMATCH AND ARE DETERMINED AT DATUM PLANE H.
  7. DIMENSION b DOES NOT INCLUDE DAM BAR PROTRUSION. DAM BAR PROTRUSION SHALL NOT CAUSE THE b DIMENSION TO EXCEED 0.35.
  8. MINIMUM SOLDER PLATE THICKNESS SHALL BE 0.0076.
- △ EXACT SHAPE OF EACH CORNER IS OPTIONAL.

DIM	MIN	MAX	DIM	MIN	MAX	DIM	MIN	MAX
A	1.4	1.6	L1	1	REF			
A1	0.05	0.15	R	0.15	0.25			
A2	1.35	1.45	S	0.2	REF			
b	0.17	0.27	θ	1°	5°			
b1	0.17	0.23	θ1	12°	REF			
c	0.09	0.2						
c1	0.09	0.16						
D	9 BSC							
D1	7 BSC							
e	0.5 BSC							
E	9 BSC							
E1	7 BSC							
L	0.5	0.7						

## 10 Part Marking Information

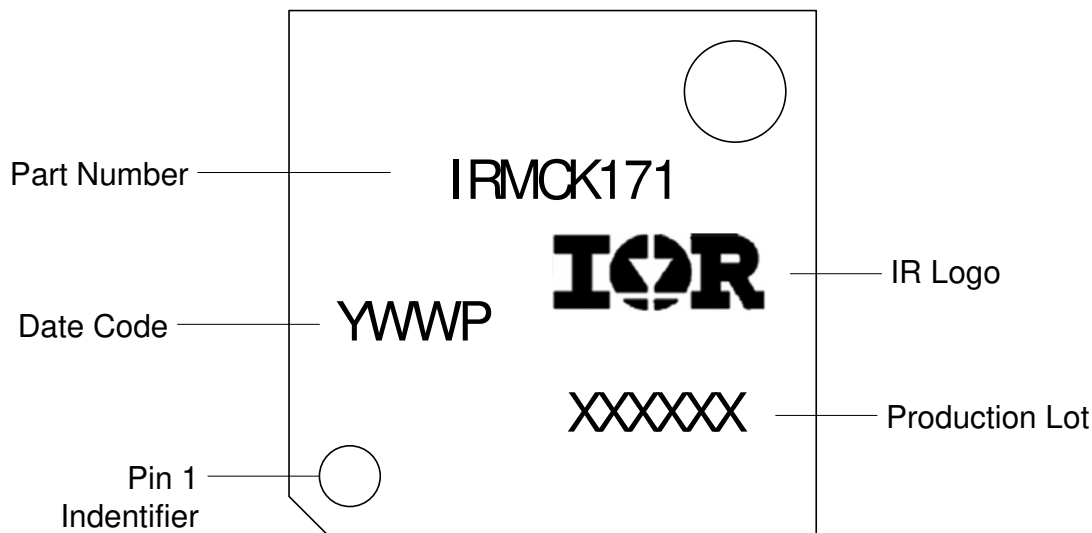

## 11 Qualification Information

<b>Qualification Level</b>		Industrial <sup>††</sup> (per JEDEC JESD 47E)
<b>Moisture Sensitivity Level</b>		MSL3 <sup>†††</sup> (per IPC/JEDEC J-STD-020C)
<b>ESD</b>	<b>Machine Model</b>	Class B (per JEDEC standard JESD22-A114D)
	<b>Human Body Model</b>	Class 2 (per EIA/JEDEC standard EIA/JESD22-A115-A)
<b>RoHS Compliant</b>		Yes

† Qualification standards can be found at International Rectifier's web site <http://www.irf.com/>

†† Higher qualification ratings may be available should the user have such requirements. Please contact your International Rectifier sales representative for further information.

††† Higher MSL ratings may be available for the specific package types listed here. Please contact your International Rectifier sales representative for further information.

International  
 Rectifier

Data and Specifications are subject to change without notice  
**IR WORLD HEADQUARTERS:** 233 Kansas St., El Segundo, California 90245, USA Tel: (310) 252-7105  
TAC Fax: (310) 252-7903

Visit us at [www.irf.com](http://www.irf.com) for sales contact information