

4

3

2

1

THIS DRAWING IS UNPUBLISHED. RELEASED FOR PUBLICATION  
 © COPYRIGHT BY TYCO ELECTRONICS CORPORATION. ALL RIGHTS RESERVED.

LOC	DIST	REVISIONS			
P	LTR	DESCRIPTION	DATE	DWN	APVD
	A	REVISED PER ECO-09-014914	6/23/09	SS	MS

- 1 CONTINUOUS STRIP ON REEL.
- 2 WIRE SIZE IS TWO #18'S AWG
- △ 3 TIN PLATE 0.002032 [.000080] MIN

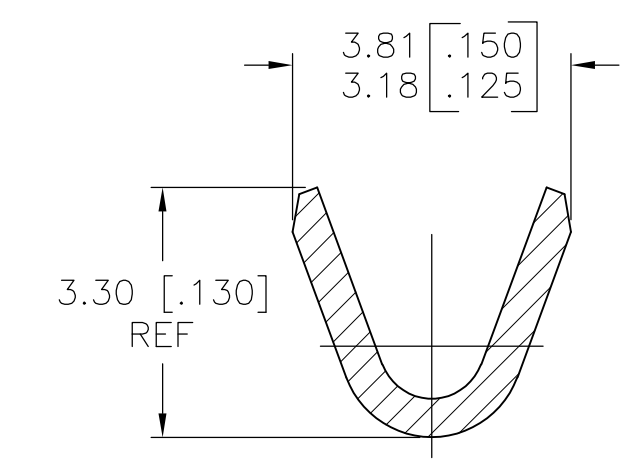
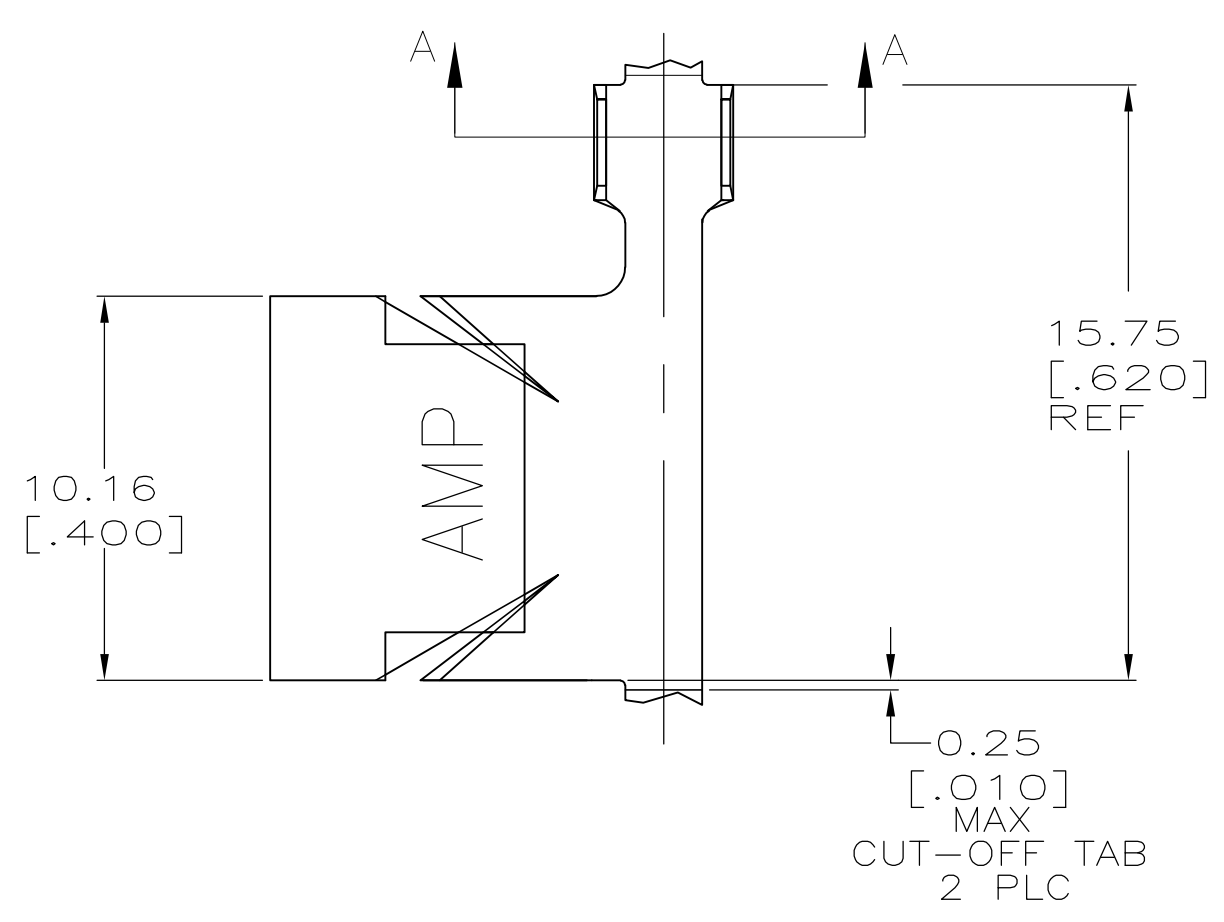
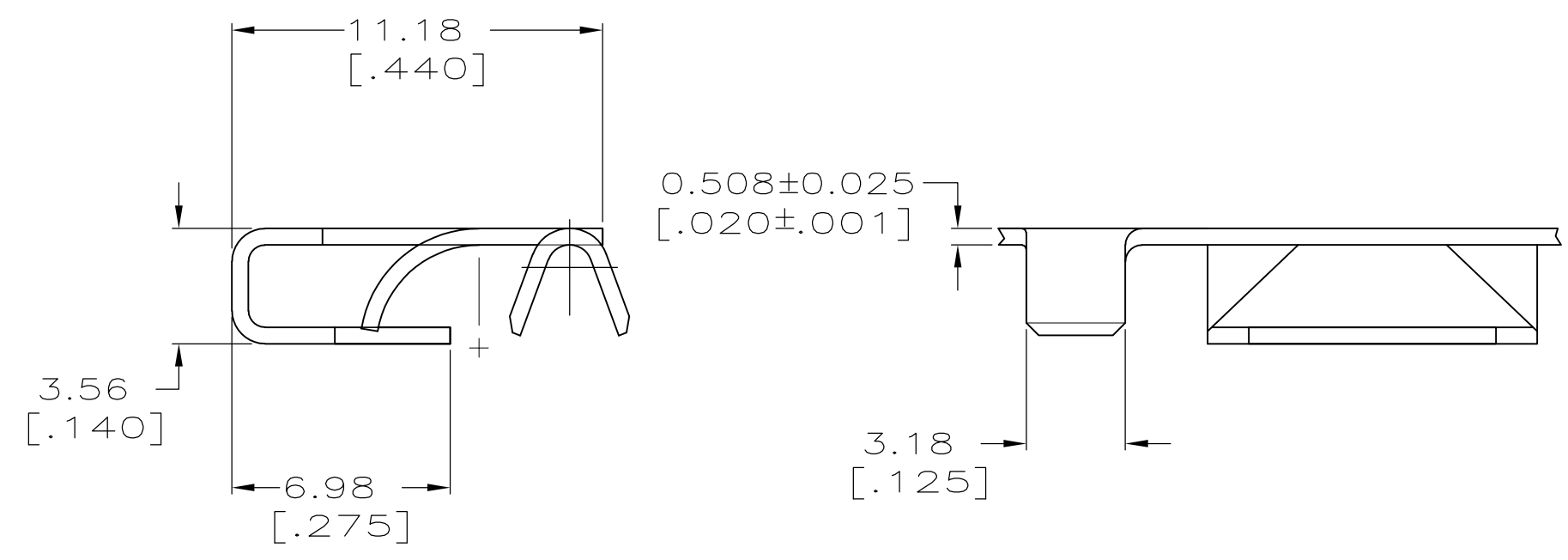

UNS G10080 TEMP 2 STEEL	1986548-1
MATERIAL	PART NO.

THIS DRAWING IS A CONTROLLED DOCUMENT.		DWN JR RUTH 04MAY09	Tyco Electronics Corporation Harrisburg, PA 17105-3608		
DIMENSIONS: MM [INCHES]		CHK MIKE STRECKEWALD 04MAY09	NAME CLIP, GROUNDING		
TOLERANCES UNLESS OTHERWISE SPECIFIED:		APVD MIKE STRECKEWALD 04MAY09	PRODUCT SPEC -		
0 PLC ± -		APPLICATION SPEC -			
1 PLC ± -		SIZE A3			
2 PLC ± 0.25 [.010]		CAGE CODE 00779			
3 PLC ± -		DRAWING NO C-1986548			
4 PLC ± -		RESTRICTED TO -			
ANGLES ± -		WEIGHT -			
MATERIAL SEE TABLE		FINISH △ 3			
		CUSTOMER DRAWING		SCALE 5:1	SHEET 1 OF 1
				REV A	