

DO NOT SCALE DRAWING  
 DIMENSION IN METRIC  
 PROJECT NO.  
 SIMILAR ITEM  
 EDP NO.  
 ENG. NO  
 SD 35711-02\*0

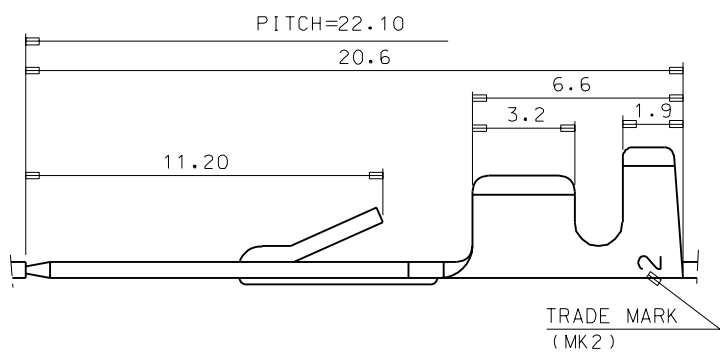
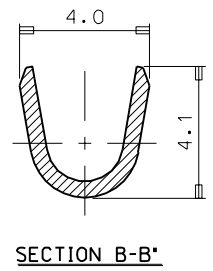
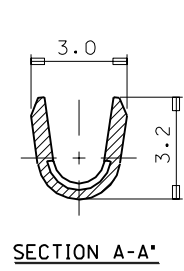
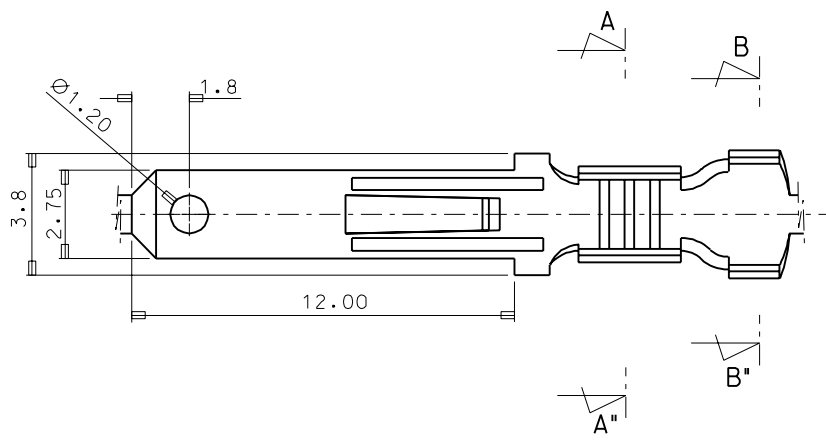

- NOTES
1. MATERIAL:BRASS, 0.5 THICKNESS
  2. FINISH:35711-0200:UNPLATED  
35711-0210:POST-TIN PLATED
  3. RECOMMENDED LENGTH OF WIRE STRIP IS 4.5-5.0mm

ASS'Y PART		QTY/REEL OR PACK	SURFACE AREA	MATERIAL	SEE NOTES	WIRE RANGE	GENERAL TOLERANCES	MOLEX MOLEX-KOREA CO.,LTD.	
DESCRIPTION	ENG.NO.	10,000 QTY/REEL	MM <sup>2</sup>			AWG: #20-#16	DIM. : ±0.30		
						MM <sup>2</sup> : 0.52-1.31 <th>ANGLE : ±0.20</th> <td rowspan="2">REVISE ONLY ON CAD SYSTEM</td>	ANGLE : ±0.20	REVISE ONLY ON CAD SYSTEM	
						INSULATION RANGE	TITLE: .110 SLIP-IN TAB		
A	CAD REDRAWING RELEASED	93-016	93.7.22	DR/CHK			ENG.NO. SD 35711-02*0	10F 1 REV A	
LTR	REVISION RECORD	ECN	DATE	DIE FEED	APPL FEED 22.1	WBDW	IBDW	APP'D BY	SCALE 7:1