

MODEL PAXCDC -DEVICENET® OUTPUT OPTION CARD



DESCRIPTION

The DeviceNet Option Card (PAXCDC30) is designed for the PAX series. It fits into the Comms slot of any PAX and allows the unit to communicate with a DeviceNet bus. The card supports Polling, Bit Strobe, and

Explicit Message Commands. The MAC ID and the Baud Rate are switch adjustable via a DIP switch. A bicolor LED is used to indicate the unit's status in relationship to the bus.

INSTALLING AN OPTION CARD



Caution: The option and main circuit cards contain static sensitive components. Before handling the cards, discharge static charges from your body by touching a grounded bare metal object. Ideally, handle the cards at a static controlled clean workstation. Also, only handle the cards by the edges. Dirt, oil or other contaminants that may contact the cards can adversely affect circuit operation.



Warning: Exposed line voltage will be present on the circuit boards when power is applied. Remove all power to the unit AND load circuits before accessing the unit.

1. When handling the main circuit board, hold it by the rear cover. When handling the option card, hold it by the terminal block.
2. Remove the main assembly from the rear of the case by squeezing both finger holds on the rear cover and pulling the assembly out of the case. Or use a small screwdriver to depress the side latches and pull the main assembly out of the case. Do not remove the rear cover from the main circuit board.
3. Install the option card by locating PAXCDC card slot location on the main circuit board. Align the option card terminal block with the PAXCDC terminal block position on the rear cover. Align the PAXCDC connector with the main circuit board option card connector and then press to fully engage the connectors. Verify that the tab on the option card rests in the alignment slot on the display board.
4. Slide the assembly back into the case. Be sure the rear cover latches fully engage in the case.
5. Apply the option card label to the bottom side of the PAX. **Do not cover the vents on the top surface of the unit.** The surface of the case must be clean for the label to adhere properly. Apply the label to the area designated by the large case label.

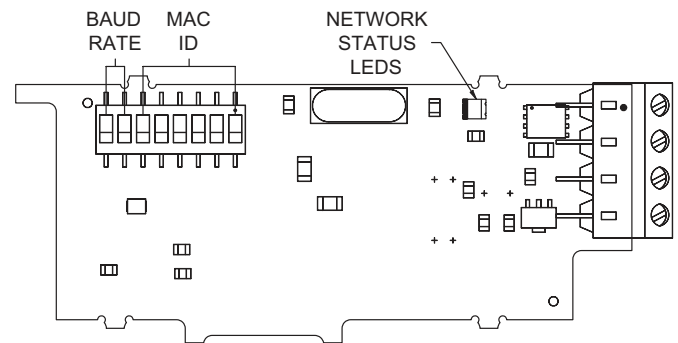
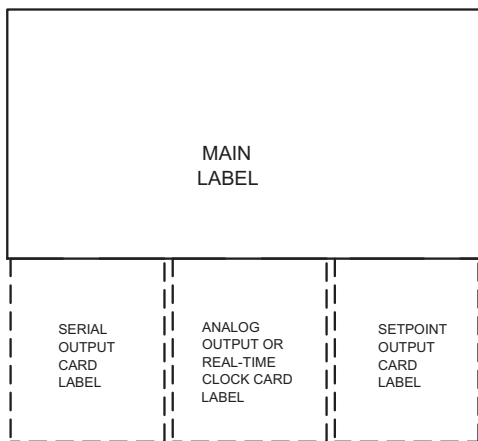
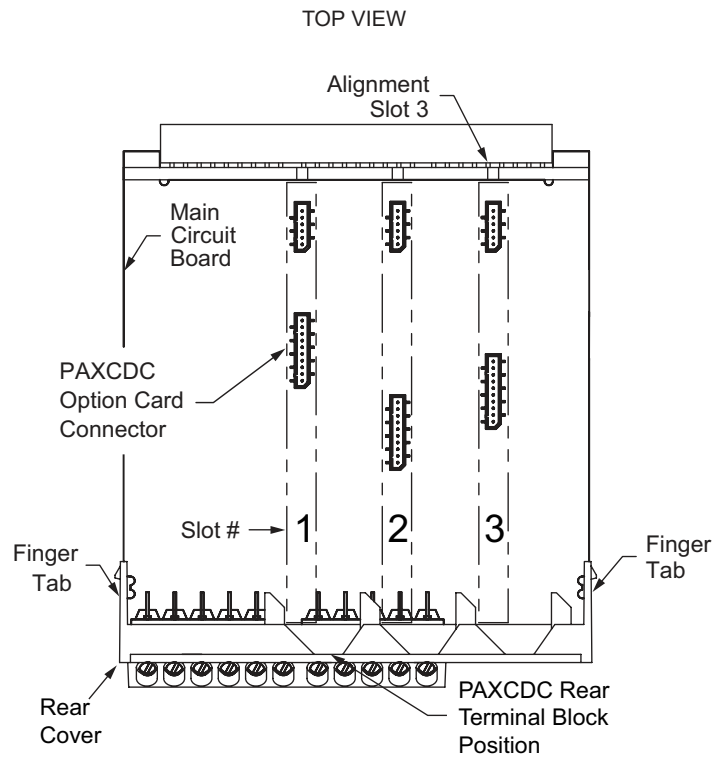

DIP SWITCHES

Both MAC ID and baud rate are set via DIP switches on the DeviceNet® option card. See the DIP switch setting table for more details on these DIP switches. Configuration of MAC ID and baud rate is not supported over DeviceNet®.

NETWORK STATUS LEDs

The network status LEDs provide visual indication to the operator of the DeviceNet® card's current status.

ORDERING INFORMATION

MODEL NO.	DESCRIPTION	PART NUMBER
PAXCDC	PAX DeviceNet® Output Card	PAXCDC30

DeviceNet[®] SPECIFICATIONS

POWER SUPPLY

Source: Supplied by DeviceNet[®] bus.
The bus does not power the PAX.

Voltage: 11 to 25 VDC.

Current:
Nominal: 40 mA at 25 VDC.
Inrush: 550 mA for 5 msec at 25 VDC.

Note: Power must be applied to the PAX unit before bus power is applied to the card.

NETWORK SPECIFICS

Compatibility: Group 2 Server Only, not UCMM capable.

Baud Rates: 125 Kbaud, 250 Kbaud, and 500 Kbaud.

Bus Interface: Phillips 82C250 or equivalent with mis-wiring protection per DeviceNet[®] Volume 1 Section 10.2.2.

Node Isolation: Bus powered, isolated node.

Host Isolation: 500 Vrms for 1 minute (50 V working) between DeviceNet[®] and PAX input common.

Bus Connection:
12 V+
13 CAN_H
14 CAN_L
15 V-
Shield: No Connection

INSTALLATION INFORMATION

Factory Settings:

Baud rate: 125 KBs.

MAC ID: 63

Strobe Register: 07h

Polling flags: All on.

Swap data flag: Off.

Store Flags: All on.

DIP SWITCH SETTING TABLE

SWITCH #	SETTING
1 - 6	MAC ID (all off = 0, all on = 63) Switch 1 is LSB (1), switch 6 is MSB (32).
7 off, 8 off	125 K baud
7 on, 8 off	250 K baud
7 off, 8 on	500 K baud
7 on, 8 on	N/A

CONNECTION SIZES

Device Profile: This product conforms to the DeviceNet[®] specification Volumes I and II of version 2.0.

Device Configuration: No DeviceNet[®] configuration is supported. However, some PAX unit configuration is supported.

MESSAGE	PRODUCED	CONSUMED
Explicit	4 Bytes	4 Bytes
Polled	4 Bytes	6 Bytes
Bit Strobe	4 Bytes	8 Bytes

NETWORK STATUS LEDs

Flashing Red LED:

This device is the only device on the network (waiting for an acknowledgment to its duplicate MAC ID check), or an I/O connection has timed out, or a recoverable error has occurred.

Flashing Green LED:

The device is functioning correctly and is waiting to be commissioned by a bus master.

Solid Red LED:

The device has encountered a non-recoverable fault, such as a duplicate MAC ID response, and has removed itself from the bus, or the device is in a power up reset state and is attempting to come on line.

Solid Green LED:

The device is on line, functioning correctly and has been commissioned by a bus master.

SUPPORTED CONNECTIONS

Polled Command: The Polled Command consumes 6 bytes of data, and is used to get, set, or reset attributes. The attribute is determined by the value in byte 0 of the data field. Refer to the Attribute Identification Chart for the appropriate value. Byte 1 determines the action: 0 = get, 1 = set, 2 = reset. The next 4 bytes are the new attribute value for the set command. For get or reset commands, enter 4 zeros. The data response from the Polled Command is in the format of a 4 byte hexadecimal number. For the get command (0), the response is the attribute value. For the set command (1), the response is an echo of the data input. For the reset command (2), all 0s are returned.

Bit Strobe Command: The Bit Strobe Command consumes eight bytes of data, or less. This is a read only predetermined attribute. The data response from the Bit Strobe Command is in the format of a 4 byte hexadecimal number. The register that will be read using the Bit Strobe command is determined by setting Attribute 2, Instance 1, Class 100* (decimal) with a value that represents the desired attribute. Refer to the Attribute Identification Chart for the appropriate value.

*Class 100 (decimal) is a vendor specific class.

EXPLICIT MESSAGE COMMAND

Get Attribute: The attribute that will be read using the Get Attribute command is determined by setting Service Code 14, Instance 1, Class 100* (decimal), and the attribute with a value that represents the desired attribute. Refer to the Attribute Identification Chart for the appropriate value. The data response from the Get Attribute Command is in the format of a 4 byte hexadecimal number.

Set Attribute: The attribute that will be set using the Set Attribute command is determined by setting Service Code 16, Instance 1, Class 100* (decimal), and the attribute with a value that represents the desired attribute. Refer to the Attribute Identification Chart for the appropriate value. The data field for the Set Attribute Command is entered as a 4 byte hexadecimal number.

Reset Attribute: The attribute that will be reset using the Reset Attribute command is determined by setting Service Code 5, Instance 1, Class 100* (decimal), and the attribute with a value that represents the desired attribute. Refer to the Attribute Identification Chart for the appropriate value.

*Class 100 (decimal) is a vendor specific class.

Note: Not all attributes respond to a Set or Reset Attribute command. Refer to the Attribute Identification Chart for details.

Vendor Specific Error Responses

CODE ERROR #	ERROR CODE MEANING
1F (General Code)	Vendor Specific Error
1 (Additional Code)	PAX unit Response Time-out
2 (Additional Code)	Vendor Service Not Supported
3 (Additional Code)	Command String Syntax Error

ATTRIBUTE IDENTIFICATION CHART - PAX, PAXI, PAXCK, PAXDP AND PAXDR

VALUE	ID	DESCRIPTION					SERVICE CODES SUPPORTED					POLLING	STORE
		PAX	PAXI	PAXCK	PAXDP	PAXDR	PAX	PAXI	PAXCK	PAXDP	PAXDR		
1		Data Swapping Flag ①					G, S	G, S	G, S	G, S	G, S	N/A	N/A
2		Bit Strobe Attribute					G, S	G, S	G, S	G, S	G, S	N/A	N/A
3		Polling Flags 1 ②					G, S	G, S	G, S	G, S	G, S	N/A	N/A
4		Polling Flags 2 ②					G, S	G, S	G, S	G, S	G, S	N/A	N/A
5		Polling Flags 3 ②					N/A	G, S	G, S	G, S	G, S	N/A	N/A
6		DIP Switch ③					G	G	G	G	G, S	N/A	N/A
7	A	Input	Count A	Timer	Input A (rel)	Rate A	G	G, S, R	G, S, R	G, R	G	Attr 3, bit 0	Attr 26, bit 0
8	B	Total	Count B	Count	Input B (rel)	Rate B	G, R	G, S, R	G, S, R	G, R	G	Attr 3, bit 1	Attr 26, bit 1
9	C	Max	Count C	RTC Time	Calc	Rate C	G, R	G, S, R	G, S	G	G	Attr 3, bit 2	Attr 26, bit 2
10	D	Min	Rate	RTC Date	Total	Total A	G, R	G, S	G, S	G, R	G, S, R	Attr 3, bit 3	Attr 26, bit 3
11	E	SP 1	Min	SP 1	Min Input	Total B	G, S, R	G, S, R	G, S, R	G, R	G, S, R	Attr 3, bit 4	Attr 26, bit 4
12	F	SP 2	Max	SP 2	Max Input	Total C	G, S, R	G, S, R	G, S, R	G, R	G, R	Attr 3, bit 5	Attr 26, bit 5
13	G	SP 3	Scale A	SP 3	Input A (abs)	Scale A	G, S, R	G, S	G, S, R	G	G, S	Attr 3, bit 6	Attr 26, bit 6
14	H	SP 4	Scale B	SP 4	Input B (abs)	Scale B	G, S, R	G, S	G, S, R	G	G, S	Attr 3, bit 7	Attr 26, bit 7
15	I	AOR ④	Scale C	SP 1 Off	Input A (offset)	Scale C	G, S	G, S	G, S	G, S	G, S	Attr 4, bit 0	Attr 27, bit 0
16	J	CSR ④	Load A	SP 2 Off	Input B (offset)	Load A	G, S	G, S	G, S	G, S	G, S	Attr 4, bit 1	Attr 27, bit 1
17	K	----	Load B	SP 3 Off	----	Load B	----	G, S	G, S	----	G, S	Attr 4, bit 2	Attr 27, bit 2
18	L	----	Load C	SP 4 Off	----	----	----	G, S	G, S	----	----	Attr 4, bit 3	Attr 27, bit 3
19	M	----	SP 1	Timer Start	SP 1	Setpoint 1	----	G, S, R	G, S	G, S, R	G, S, R	Attr 4, bit 4	Attr 27, bit 4
20	O	----	SP 2	Count Start	SP 2	Setpoint 2	----	G, S, R	G, S	G, S, R	G, S, R	Attr 4, bit 5	Attr 27, bit 5
21	Q	----	SP 3	Timer Stop	SP 3	Setpoint 3	----	G, S, R	G, S	G, S, R	G, S, R	Attr 4, bit 6	Attr 27, bit 6
22	S	----	SP 4	Count Stop	SP 4	Setpoint 4	----	G, S, R	G, S	G, S, R	G, S, R	Attr 4, bit 7	Attr 27, bit 7
23	U	----	MMR ④	MMR ④	MMR ④	MMR ④	----	G, S	G, S	G, S	G, S	Attr 5, bit 0	Attr 28, bit 0
24	W	----	AOR ④	RTC Day	AOR ④	AOR ④	----	G, S	G, S	G, S	G, S	Attr 5, bit 1	Attr 28, bit 1
25	X	----	SOR ④	SOR ④	SOR ④	SOR ④	----	G, S	G, S	G, S	G, S	Attr 5, bit 2	Attr 28, bit 2
26		Store Flags 1 ⑤					G, S	G, S	G, S	G, S	G, S	N/A	N/A
27		Store Flags 2 ⑤					G, S	G, S	G, S	G, S	G, S	N/A	N/A
28		Store Flags 3 ⑤					N/A	G, S	G, S	G, S	G, S	N/A	N/A

ATTRIBUTE IDENTIFICATION CHART - PAX2A, PAX2C, PAX2D AND PAX2S

VALUE	ID	DESCRIPTION				SERVICE CODES SUPPORTED				POLLING	STORE
		PAX2A	PAX2C	PAX2D	PAX2S	PAX2A	PAX2C	PAX2D	PAX2S		
1		Data Swapping Flag ①				G, S	G, S	G, S	G, S	N/A	N/A
2		Bit Strobe Attribute				G, S	G, S	G, S	G, S	N/A	N/A
3		Polling Flags 1 ②				G, S	G, S	G, S	G, S	N/A	N/A
4		Polling Flags 2 ②				G, S	G, S	G, S	G, S	N/A	N/A
5		Polling Flags 3 ②				G, S	G, S	G, S	G, S	N/A	N/A
6		DIP Switch ③				G, S	G, S	G, S	G, S	N/A	N/A
7	A	Input (rel)	Input (PV)	Count A	Input (relative)	G, R	G	G, S, R	G, R	Attr 3, bit 0	Attr 26, bit 0
8	B	Total	Active Setpoint	Count B	Total	G, R	G, S	G, S, R	G, R	Attr 3, bit 1	Attr 26, bit 1
9	C	Max. Input	Setpoint Ramp Rate	Count C	Max. Input	G, R	G, S	G, S, R	G, R	Attr 3, bit 2	Attr 26, bit 2
10	D	Min. Input	Output Power	Rate A	Min. Input	G, R	G, S	G	G, R	Attr 3, bit 3	Attr 26, bit 3
11	E	Setpoint 1	Proportional Band	Rate B	Setpoint 1	G, S, R	G, S	G	G, S, R	Attr 3, bit 4	Attr 26, bit 4
12	F	Setpoint 2	Integral Time	Rate C	Setpoint 2	G, S, R	G, S	G	G, S, R	Attr 3, bit 5	Attr 26, bit 5
13	G	Setpoint 3	Derivative Time	Max (Hi) Value	Setpoint 3	G, S, R	G, S	G, S, R	G, S, R	Attr 3, bit 6	Attr 26, bit 6
14	H	Setpoint 4	Alarm Status (1-4)	Min (Lo) Value	Setpoint 4	G, S, R	G, S	G, S, R	G, S, R	Attr 3, bit 7	Attr 26, bit 7
15	I	Band/Dev 1	Alarm Value 1	Scale Factor A	Band/Dev 1	G, S	G, S, R	G, S	G, S	Attr 4, bit 0	Attr 27, bit 0
16	J	Band/Dev 2	Alarm Value 2	Scale Factor B	Band/Dev 2	G, S	G, S, R	G, S	G, S	Attr 4, bit 1	Attr 27, bit 1
17	K	Band/Dev 3	Alarm Value 3	Cnt Load A	Band/Dev 3	G, S	G, S, R	G, S	G, S	Attr 4, bit 2	Attr 27, bit 2
18	L	Band/Dev 4	Alarm Value 4	Cnt Load B	Band/Dev 4	G, S	G, S, R	G, S	G, S	Attr 4, bit 3	Attr 27, bit 3
19	M	Input (abs)	----	Setpoint 1	Gross (Absolute)	G	----	G, S, R	G	Attr 4, bit 4	Attr 27, bit 4
20	O	Input Offset	----	Setpoint 2	Tare (Offset) Value	G, S	----	G, S, R	G, S, R	Attr 4, bit 5	Attr 27, bit 5
21	Q	----	----	Setpoint 3	----	----	----	G, S, R	----	Attr 4, bit 6	Attr 27, bit 6
22	S	----	----	Setpoint 4	----	----	----	G, S, R	----	Attr 4, bit 7	Attr 27, bit 7
23	U	MMR ④	----	MMR ④	MMR ④	G, S	----	G, S	G, S	Attr 5, bit 0	Attr 28, bit 0
24	W	AOR ④	----	AOR ④	AOR ④	G, S	----	G, S	G, S	Attr 5, bit 1	Attr 28, bit 1
25	X	SOR ④	----	SOR ④	SOR ④	G, S	----	G, S	G, S	Attr 5, bit 2	Attr 28, bit 2
26		Store Flags 1 ⑤				G, S	G, S	G, S	G, S	N/A	N/A
27		Store Flags 2 ⑤				G, S	G, S	G, S	G, S	N/A	N/A
28		Store Flags 3 ⑤				G, S	G, S	G, S	G, S	N/A	N/A

① Data Swap: (1 byte), Attribute 1, Instance 1, Class 100 (decimal). Data is normally sent and entered as follows: Pax display value = 500000 (7A120h). 4 byte value sent would be 20 A1 07 00. Setting the data swap value to 1 would result in the data being sent as 00 07 A1 20. This attribute can only be set to 0 or 1, all other values are ignored. The factory setting value is 0. Data Byte is saved in EEPROM memory.

② Polling Flags: (3 bytes) Attribute 3 - 5, Instance 1, Class 100 (decimal). The DeviceNet card is continually requesting values from the PAX unit. The polling flags determine what values are requested during each loop. Setting the flags to "1" enables the card to poll that particular value. A "0" value disables it. Turning polling flags off allows the card to request fewer values and therefore decreases the internal loop time, which allows the values that are polled to be updated more often.

TYPICAL UPDATE TIMES	
PAX	PAXI/PAXCK/PAXDP
All values (10) – 1.00 sec	All values (19) – 750 msec
5 values – 500 msec	10 values – 430 msec
1 value – 100 msec	5 values – 230 msec
	1 value – 52 msec

If a Set Attribute is executed for any value, that value is automatically updated to the latest value, regardless of whether the polling flag is on or off. On power up, all values are updated regardless of Polling flag settings. Polling flag values are saved in EEPROM memory. Factory settings is "on" for all Polling flags.
See Meter Attribute Identification Chart for polling flags.

③ DIP Switch Values: (1 byte), Attribute 6, Instance 1, Class 100 (decimal). Returns the dip switch setting. Switch 1 = LSB, 1 = on.

④ Indicates PAX Manual Mode Registers. See next section for descriptions of these registers.

⑤ Store Flags: (3 bytes) Attribute 26 - 28, Instance 1, Class 100 (decimal). This set of flags determines whether the attribute is stored to EEPROM when a Set or Reset service code is executed. If the flag is 0, the value is not saved to EEPROM memory in the PAX. If the flag is 1, the value is saved immediately to EEPROM memory in the PAX. Factory setting is "on" for all Store Flags. The attributes are grouped in blocks. Storing one attribute may cause others to be stored. If an attribute is SET frequently, its store flag should be set to 0 to increase EEPROM life.

MANUAL MODE DESCRIPTION

(CSR) Control Status Register [16] (PAX Analog Only)

The Control Status Register is used to directly control the PAX unit's outputs (setpoints and analog output), or view the state of the setpoint outputs and the status of the temperature sensor (PAXT only). The attribute is bit mapped with each bit position within the attribute assigned to a particular control function. The control functions are invoked by writing to each bit position. The bit position definitions are:

bit 0: SP1 Output	} 0 = output off 1 = output on	bit 5: Always stays 0, even if 1 is sent.
bit 1: SP2 Output		bit 6: Sensor Status (PAXT only)
bit 2: SP3 Output		0 = sensor normal
bit 3: SP4 Output		1 = sensor fail
bit 4: Manual Mode		bit 7: Always stays 0, even if 1 is sent.
0 = automatic mode		
1 = manual mode		

In Manual Mode, the setpoint outputs are defined by the values written to bits b0, b1, b2, b3; and the analog output is defined by the value written to the AOR. Internal control of these outputs is then overridden. In automatic mode, the setpoint outputs can only be reset off.

Example:

- Select manual mode for all outputs:
Value to write to attribute 16: 0010h

(MMR) Auto/Manual Mode Register [23] (PAXI/PAXCK/PAXDP/PAX2/PAXDR – Not PAX2C)

This attribute sets the controlling mode for the outputs. In Auto Mode (0) the PAX controls the setpoint output. In Manual Mode (1) the outputs are defined by the attribute SOR. When transferring from auto mode to manual mode, the PAX holds the last output value (until the attribute is changed by a write). Each output may be independently changed to auto or manual. Select values to place in manual mode by writing appropriate value to attribute 23. The bit position definitions are:

PAXI/PAXDP/PAX2/PAXDR	PAXCK
bit 0: Analog Output	bit 0: SP4
bit 1: SP4	bit 1: SP3
bit 2: SP3	bit 2: SP2
bit 3: SP2	bit 3: SP1
bit 4: SP1	
} 0 = Auto Mode 1 = Manual Mode	} 0 = Auto Mode 1 = Manual Mode

Example:

- Select manual mode for all outputs and AOR:
Value to write to attribute 23: 001Fh

(SOR) Setpoint Output Register [25] (PAXI/PAXCK/PAXDP/PAX2/PAXDR – Not PAX2C)

This attribute is used to view or change the states of the setpoint outputs. Reading from this attribute will show the present state of all the setpoint outputs. A "0" in the setpoint location means the output is inactive and a "1" means the output is active.

In Automatic Mode (See MMR Description), the PAX unit determines the setpoint output state. In Manual Mode, writing to this attribute will change the output state. The bit position definitions are:

bit 0: SP1	} 0 = Output off 1 = Output on
bit 1: SP2	
bit 2: SP3	
bit 3: SP4	

Examples:

- Turn all outputs on:
Value to write to attribute 25 - 000Fh.
- Turn outputs 1, 3 on:
Value to write to attribute 25 - 0005h.
- Turn all outputs off:
Value to write to attribute 25 - 0000h.

(AOR) Analog Output Register (Not PAXCK/PAX2C)

The Analog Output Register controls the analog output of the PAX unit. The manual mode must first be engaged by setting bit 4 of the CSR (PAX) or bit 0 of the MMR (PAXI). The range of values of this attribute is 0 to 4095, which corresponds to 0 mA, 0 V and 20 mA, 10 V; respectively. If a value larger than 4095 is written to the AOR Attribute, 4095 will be loaded. The table lists correspondence of the output signal with the attribute value.

**Due to the absolute accuracy rating and resolution of the output card, the actual output signal may differ 0.15% FS from the table values. The output signal corresponds to the range selected (20 mA or 10 V).*

Attribute Value	Output Signal*	
	I (mA)	V (V)
0	0.000	0.000
1	0.005	0.0025
2047	10.000	5.000
4094	19.995	9.9975
4095	20.000	10.000

Writing to this attribute while the analog output is in the manual mode causes the output signal to update immediately. While in the automatic mode, this attribute may be written to, but the PAX unit's output will not update until placed in manual mode.

Examples:

- Set output to full scale:
Value to write to attribute 15 (PAX) or attribute 24 (PAXI) - 0FFFh (4095).
- Set output to zero scale:
Value to write to attribute 15 (PAX) or attribute 24 (PAXI) - 0000h (0).