

THIS DRAWING IS UNPUBLISHED. RELEASED FOR PUBLICATION OCT. 2001.
 © COPYRIGHT 2001 By - ALL RIGHTS RESERVED.

LOC	DIST	REVISIONS					
ES		P	LTR	DESCRIPTION	DATE	DWN	APVD
			M2	REVISED PER ECO-11-005033	25MAR11	RK	HMR

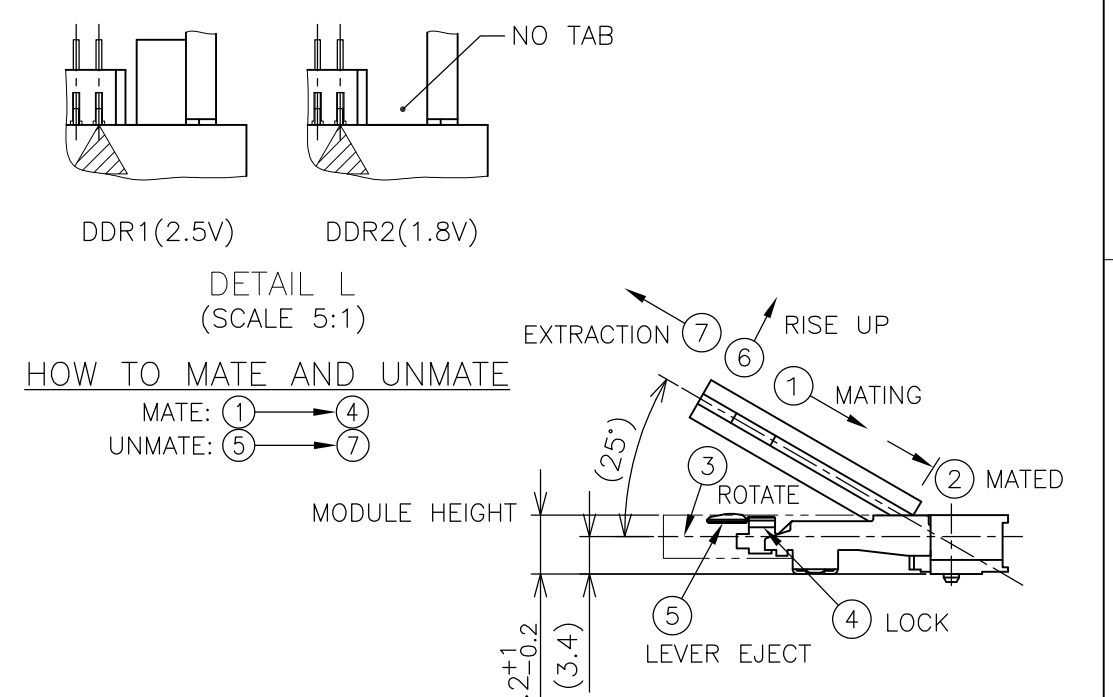

- (APPLIED TO SHEET 1-2)
- 1. MATERIAL ; HOUSING: HIGH TEMPERATURE THERMO PLASTIC UL94V-0
 CONTACT: COPPER ARROY
 LOCK LEVER STAINLESS STEEL
 SOLDER PEG: COPPER ARROY
 - △ FINISH ; CONTACT AREA: GOLD FLASH ON 0.0013MIN ALL OVER NICKEL.
 SOLDERING AREA: GOLD FLASH PLT.
 SOLDER PEG: TIN PLATING.
 - △ MECHANICAL KEY POSITION OF CONNECTOR SEE TABLE.
 - △ TOLERANCES NON-CUMULATIVE.
 - △ NOT TO SCALE.
 - △ [] INSIDE MUST BE RESIST COAT EXCEPT SOLDER PATTERN.
 - 7. IF THE MODULE DOESN'T INSERT AND LOCK IN THE LATCH SMOOTHLY, OPEN WIDE BOTH LATCHES BY MANUAL. AND THE MODULE MUST BE INSERTED AND LOCKED IN THE LATCH.
 - △ FINISH ; CONTACT AREA: 0.00076 GOLD ON 0.0013MIN ALL OVER NICKEL.
 SOLDERING AREA: GOLD FLASH PLT.
 SOLDER PEG: TIN PLATING.

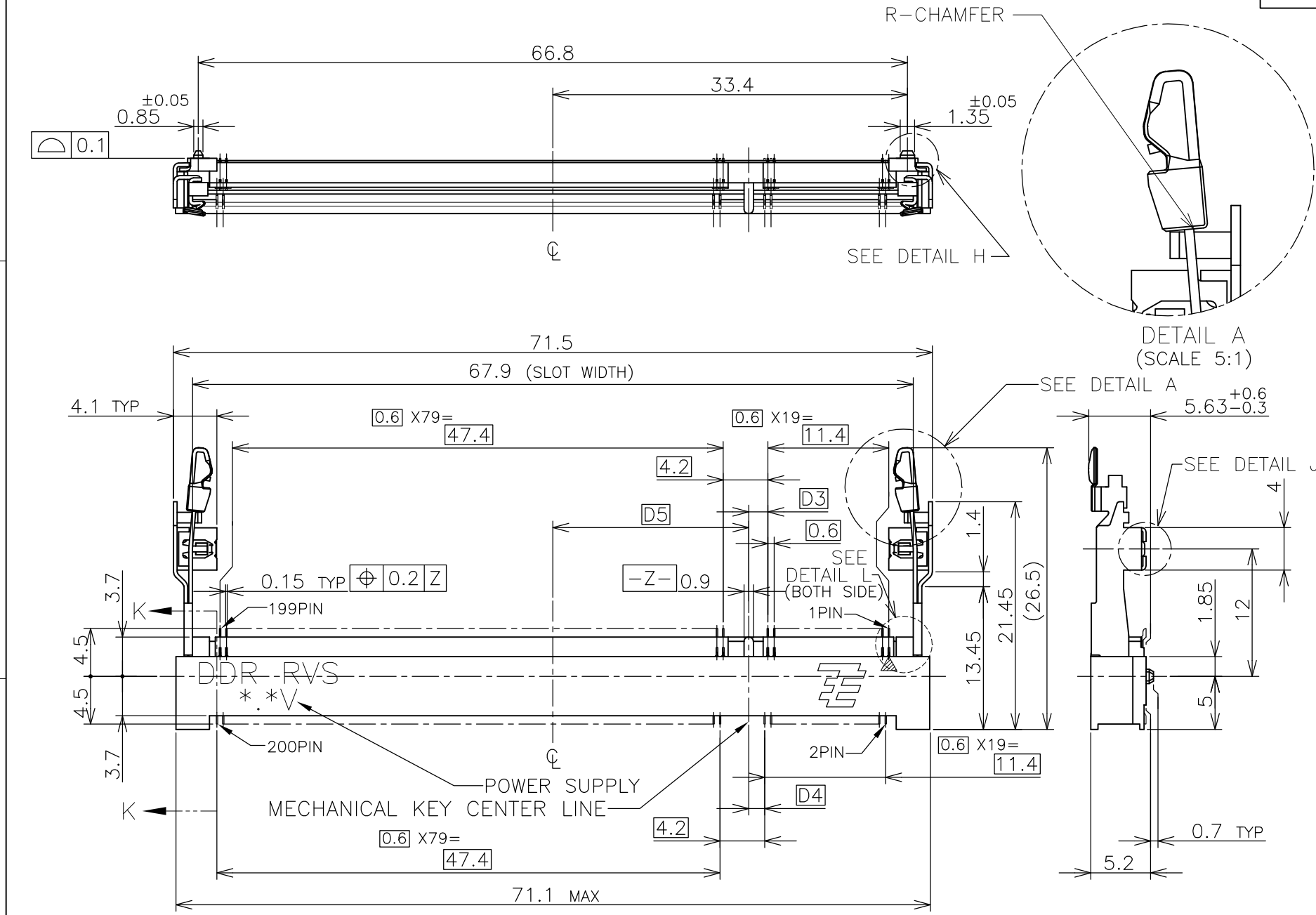
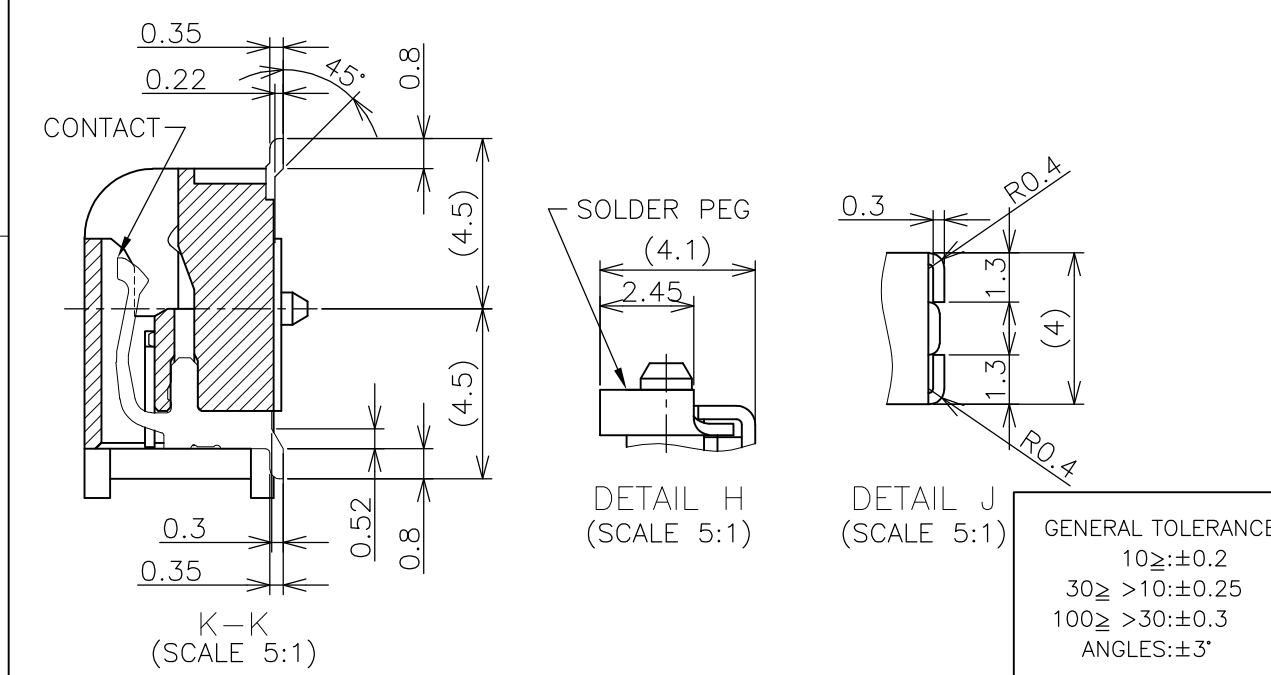

△	AVAILABLE	1.8V (DDR2)	17.55	2.4	2.7	200	1473150-6
△	AVAILABLE	1.8V (DDR2)	17.55	2.4	2.7	200	1-1473150-4
△	AVAILABLE	1.8V (DDR2)	17.55	2.4	2.7	200	1473150-4
△	AVAILABLE	2.5V (DDR1)	18.45	1.5	1.8	200	1473150-1
△	TOOLING STATUS	POWER SUPPLY	D5	D4	D3	POS	PART NO.
THIS DRAWING IS A CONTROLLED DOCUMENT.			DWN	B.WONG		20JUL10	
			CHK	C.WANG		20JUL10	
			APVD	S.YAO		20JUL10	
DIMENSIONS: MM			TOLERANCES UNLESS OTHERWISE SPECIFIED:		NAME		
0 PLC ± -			1 PLC ± -		DWN B.WONG		
2 PLC ± -			3 PLC ± -		CHK C.WANG		
3 PLC ± -			4 PLC ± -		APVD S.YAO		
ANGLES ± -			FINISH ± -		NAME		
MATERIAL			WEIGHT		PRODUCT SPEC		
			4.7g		108-5701		
			CUSTOMER DRAWING		APPLICATION SPEC		
			SCALE		DRAWING NO		RESTRICTED TO
			2:1		A300779 C-1473150		
			SHEET		REV		
			1 OF 4		M2		

THIS DRAWING IS UNPUBLISHED. RELEASED FOR PUBLICATION OCT ,2001.
 © COPYRIGHT 2001 By - ALL RIGHTS RESERVED.

LOC	DIST	REVISIONS			
P	LTR	DESCRIPTION	DATE	DWN	APVD
ES	/	SEE SHEET 1	-	-	-

REFERENCE P.C.BOARD PATTERN LAYOUT (CONNECTOR MOUNTING SIDE)

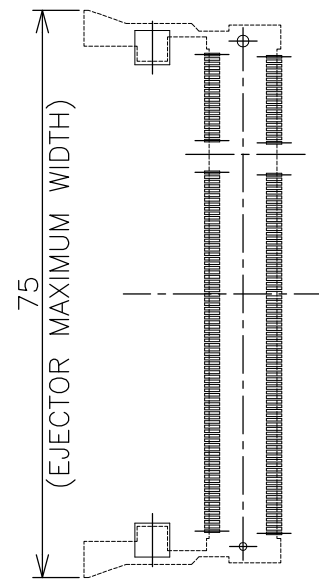

REAL SIZE (SCALE 1:1)

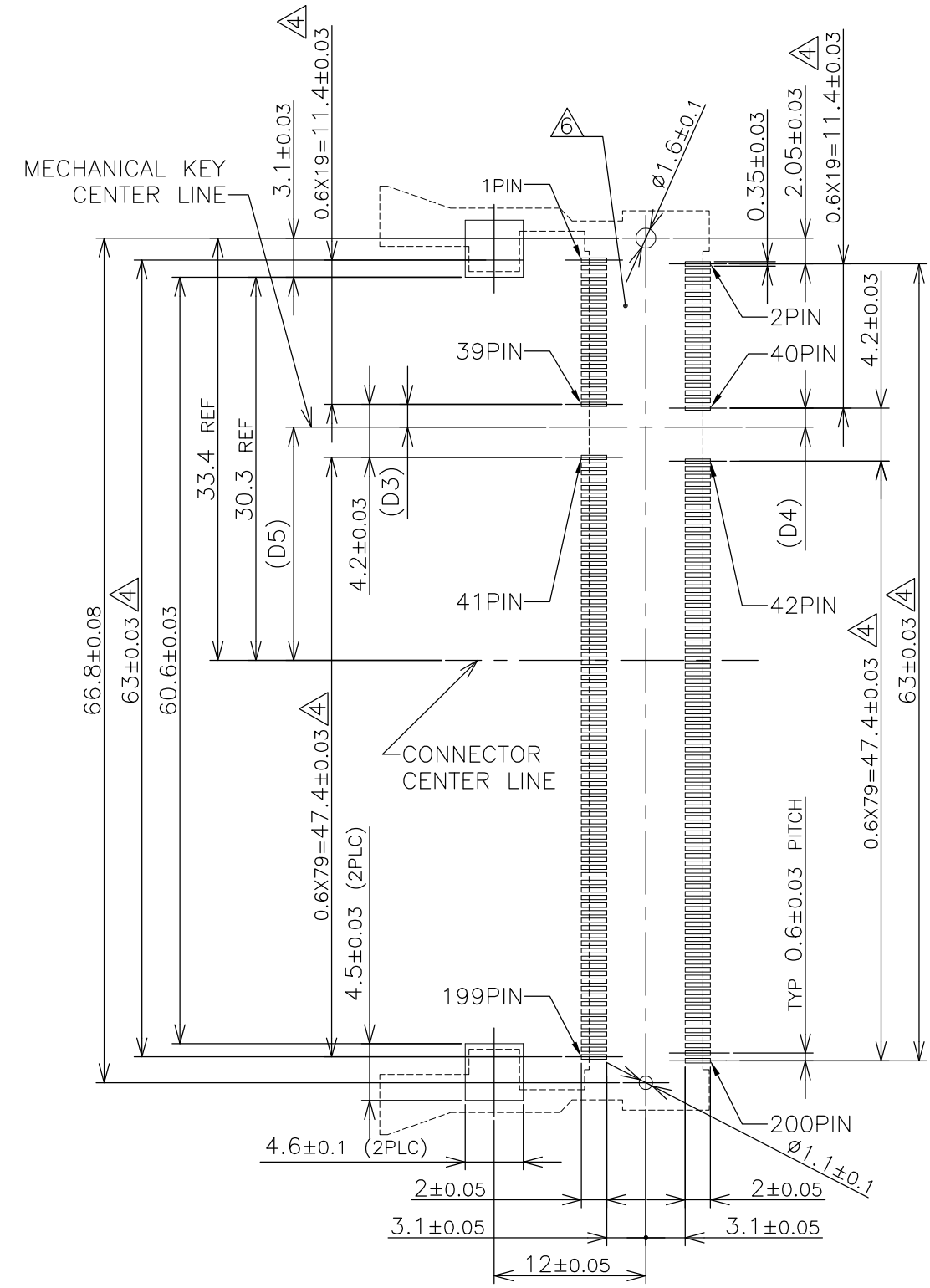

1.8V	17.55	2.4	2.7
2.5V	18.45	1.5	1.8
POWER SUPPLY	D5	D4	D3

THIS DRAWING IS A CONTROLLED DOCUMENT.		DWN	STE TE Connectivity	
DIMENSIONS: MM		CHK		
TOLERANCES UNLESS OTHERWISE SPECIFIED:		APVD	NAME	
0 PLC ±		PRODUCT SPEC	DDR1 & DDR2 SODIMM SOCKET	
1 PLC ±		APPLICATION SPEC	0.6mm PITCH 200POS	
2 PLC ±		WEIGHT	STANDARD PROFILE REVERSE TYPE (NEW LATCH TYPE)	
3 PLC ±		CUSTOMER DRAWING	SIZE	RESTRICTED TO
4 PLC ±			A3	-
ANGLES ±		CAGE CODE		DRAWING NO
FINISH		A300779		C-1473150
MATERIAL		SCALE		SHEET
		2:1		2 OF 4
		REV		M2

THIS DRAWING IS UNPUBLISHED. RELEASED FOR PUBLICATION OCT ,2001.
 © COPYRIGHT 2001 By - ALL RIGHTS RESERVED.

LOC	DIST	REVISIONS			
P	LTR	DESCRIPTION	DATE	DWN	APVD
ES		SEE SHEET 1	-	-	-

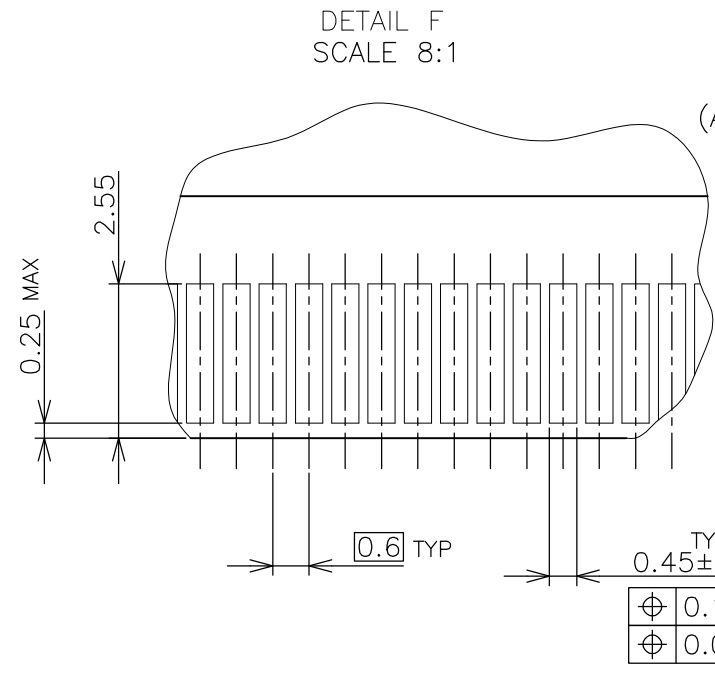
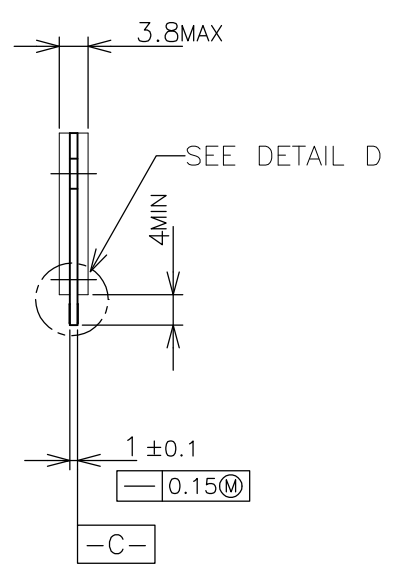
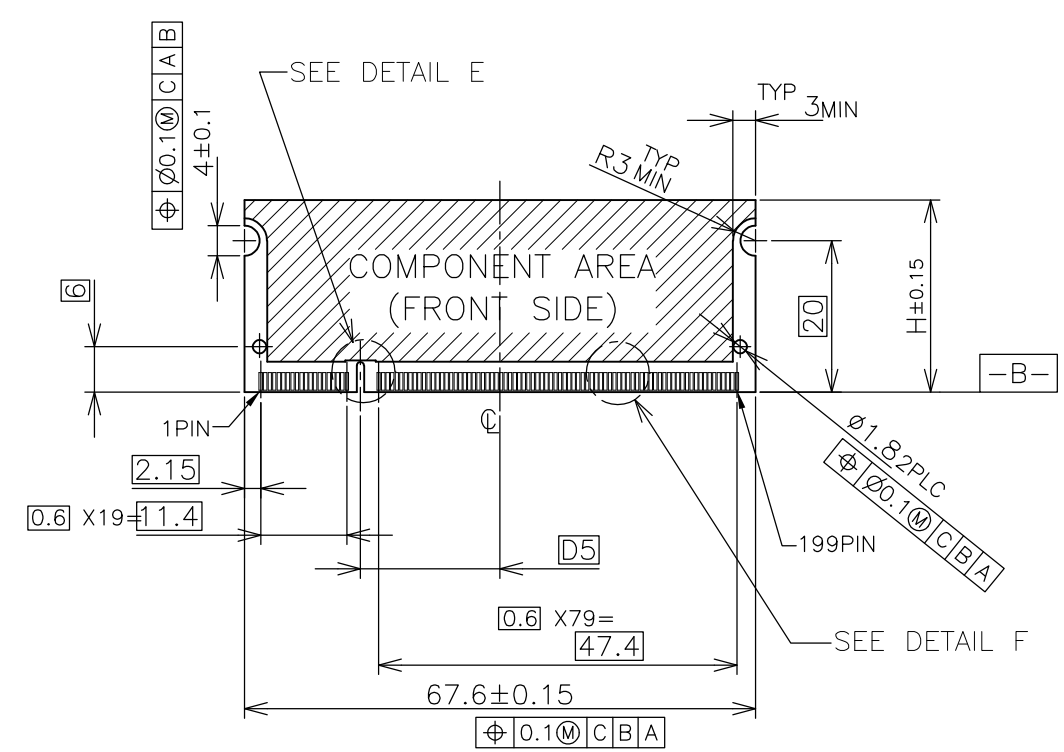

- (APPLIED TO SHEET 3)
- TOLERANCES ON ALL DIMENSIONS ±0.15 UNLESS OTHERWISE SPECIFIED.
 - P.C. BOARD THICKNESS APPLIES ACROSS TABS AND INCLUDES PLATING AND/OR METALIZATION.
 - FINISH OF PAD : GOLD PLATING 0.00076 MIN. OVER Ni PLATING 0.002MIN.
- △ NO BURR
 △ CHAMFER 0.25 MAX x 45° IF EXIST.

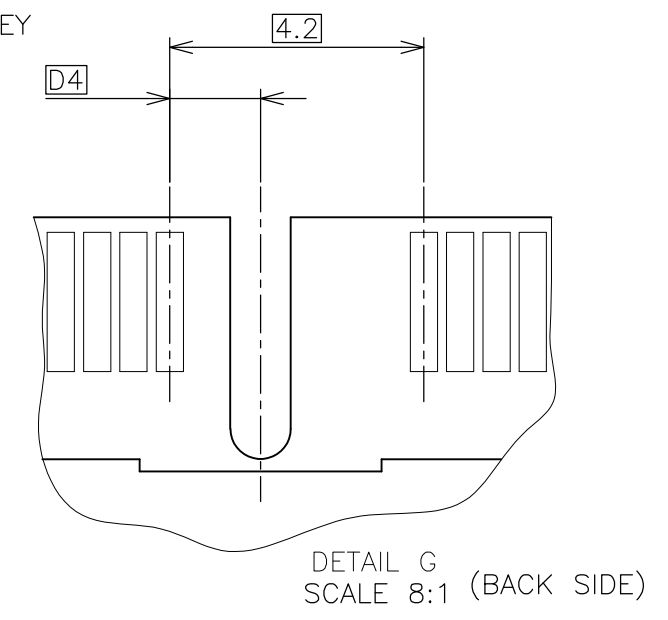
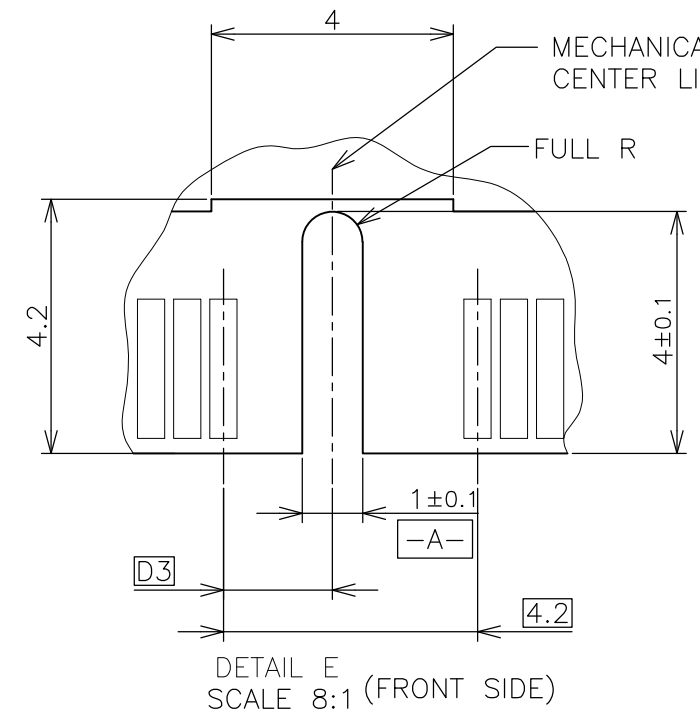
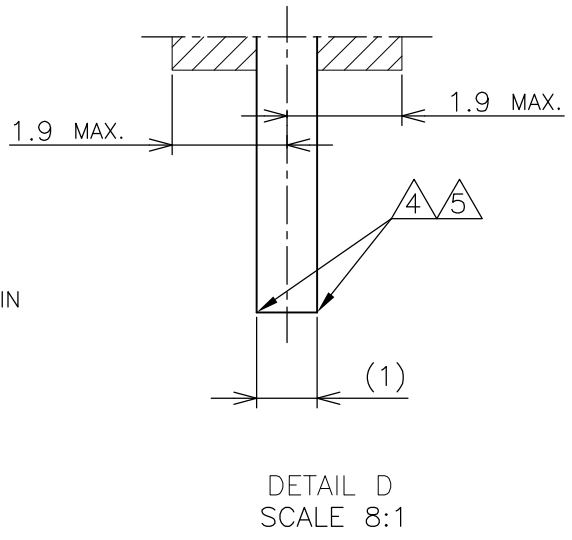
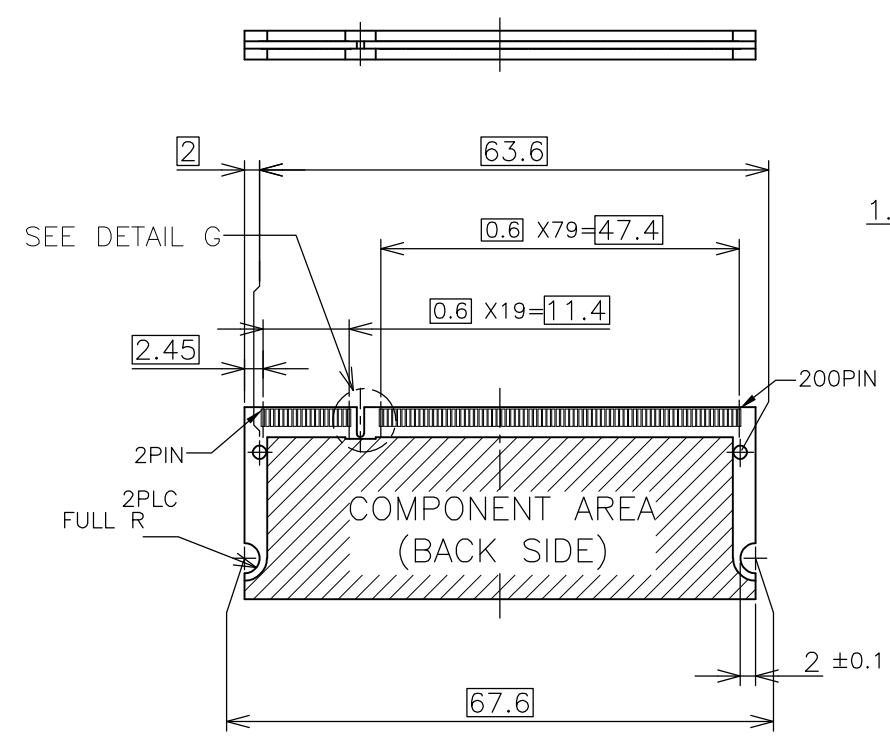

RECOMMENDED MATING P.C.B CONFIGURATION

31.75	1.8V	17.55	2.4	2.7
25.4	2.5V	18.45	1.5	1.8
H	POWER SUPPLY	D5	D4	D3

THIS DRAWING IS A CONTROLLED DOCUMENT.		DWN	TE Connectivity NAME DDR1 & DDR2 SODIMM SOCKET 0.6mm PITCH 200POS STANDARD PROFILE REVERSE TYPE (NEW LATCH TYPE)			
DIMENSIONS: MM		CHK				
TOLERANCES UNLESS OTHERWISE SPECIFIED:		APVD				
0 PLC ± 1 PLC ± 2 PLC ± 3 PLC ± 4 PLC ± ANGLES ± FINISH ±		PRODUCT SPEC				
MATERIAL		APPL. SPEC	SIZE	CAGE CODE	DRAWING NO	RESTRICTED TO
		WEIGHT	A300779		C-1473150	
		CUSTOMER DRAWING	SCALE	2:1	SHEET	3 OF 4
					REV	M2

THIS DRAWING IS UNPUBLISHED. RELEASED FOR PUBLICATION OCT ,2001.
 © COPYRIGHT 2001 By - ALL RIGHTS RESERVED.

LOC		DIST		REVISIONS			
P	LTR	DESCRIPTION		DATE	DWN	APVD	
	-	SEE SHEET 1		-	-	-	

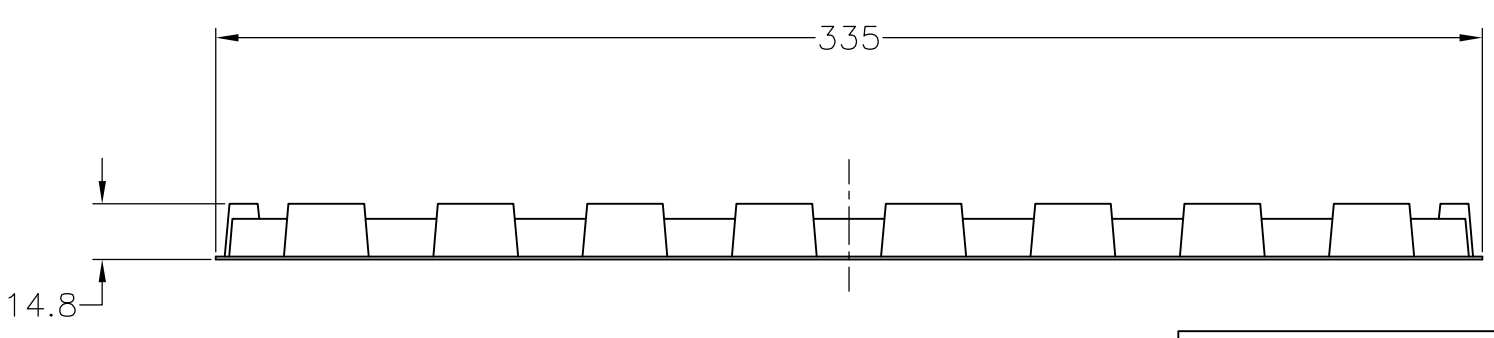
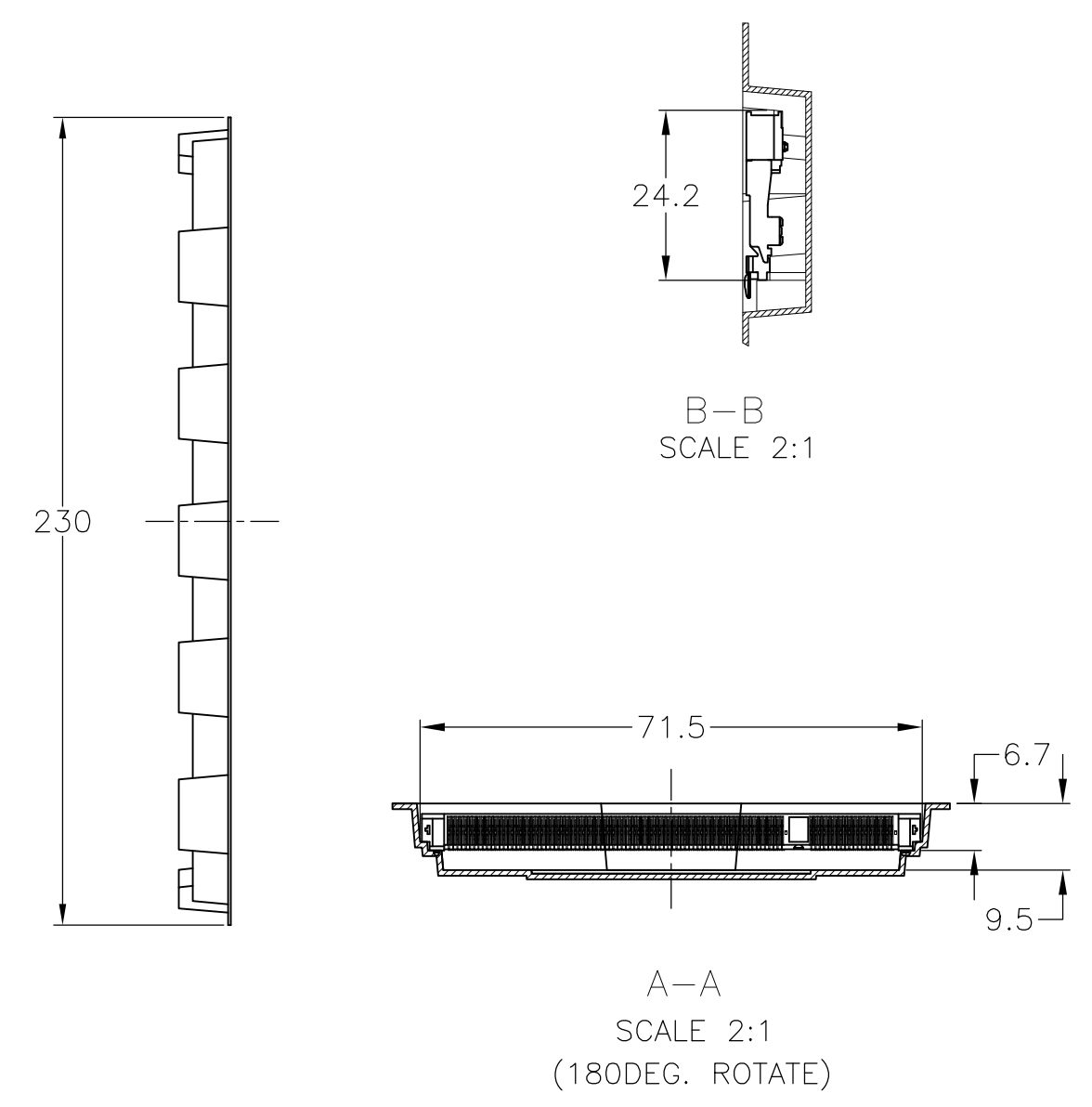
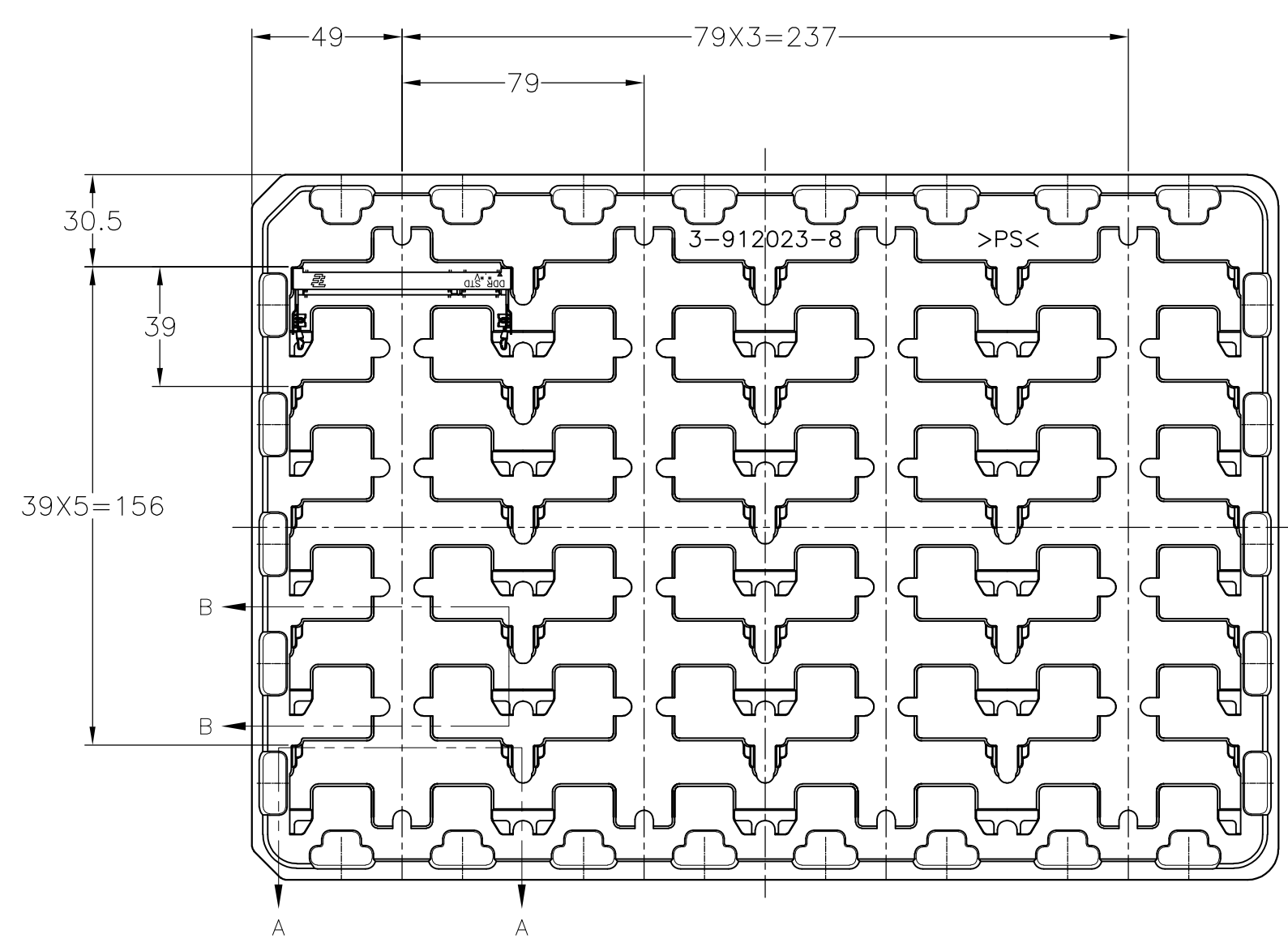

REMARK	QTY	P/N
DDR2	20EA/TRAY	1473150-6
DDR2	20EA/TRAY	1-1473150-4
DDR2	20EA/TRAY	1473150-4
DDR1	20EA/TRAY	1473150-1

- (APPLIED TO SHEET 4)
1. THE DIRECTION OF EACH CONNECTOR ON A TRAY IS REFERRED TO THIS DRAWING.
 2. GENERAL TOLERANCE: ±0.5

THIS DRAWING IS A CONTROLLED DOCUMENT.		DWN		STE TE Connectivity	
DIMENSIONS: MM		CHK			
TOLERANCES UNLESS OTHERWISE SPECIFIED:		APVD		NAME	
0 PLC ±		PRODUCT SPEC		DDR1 & DDR2 SODIMM SOCKET	
1 PLC ±		APPLICATION SPEC		0.6mm PITCH 200POS	
2 PLC ±		WEIGHT		STANDARD PROFILE REVERSE TYPE (NEW LATCH TYPE)	
3 PLC ±		CUSTOMER DRAWING		SIZE	
4 PLC ±		SCALE 1:2		CAGE CODE	
ANGLES ±		SHEET 4 OF 4		DRAWING NO	
FINISH		REV M2		RESTRICTED TO	