

| LOC |     | DIST                      |           | REVISONS |      |  |  |
|-----|-----|---------------------------|-----------|----------|------|--|--|
| P   | LTN | DESCRIPTION               | DATE      | DWN      | APVD |  |  |
| B2  |     | REVISED PER ECO-11-004835 | 11MAR2011 | RK       | HMR  |  |  |
| B3  |     | REVISED PER ECO-19-002570 | 26DEC2018 | JY       | SH   |  |  |
| B4  |     | REVISED PER ECO-20-004397 | 26MAR2020 | TX       | DZ   |  |  |

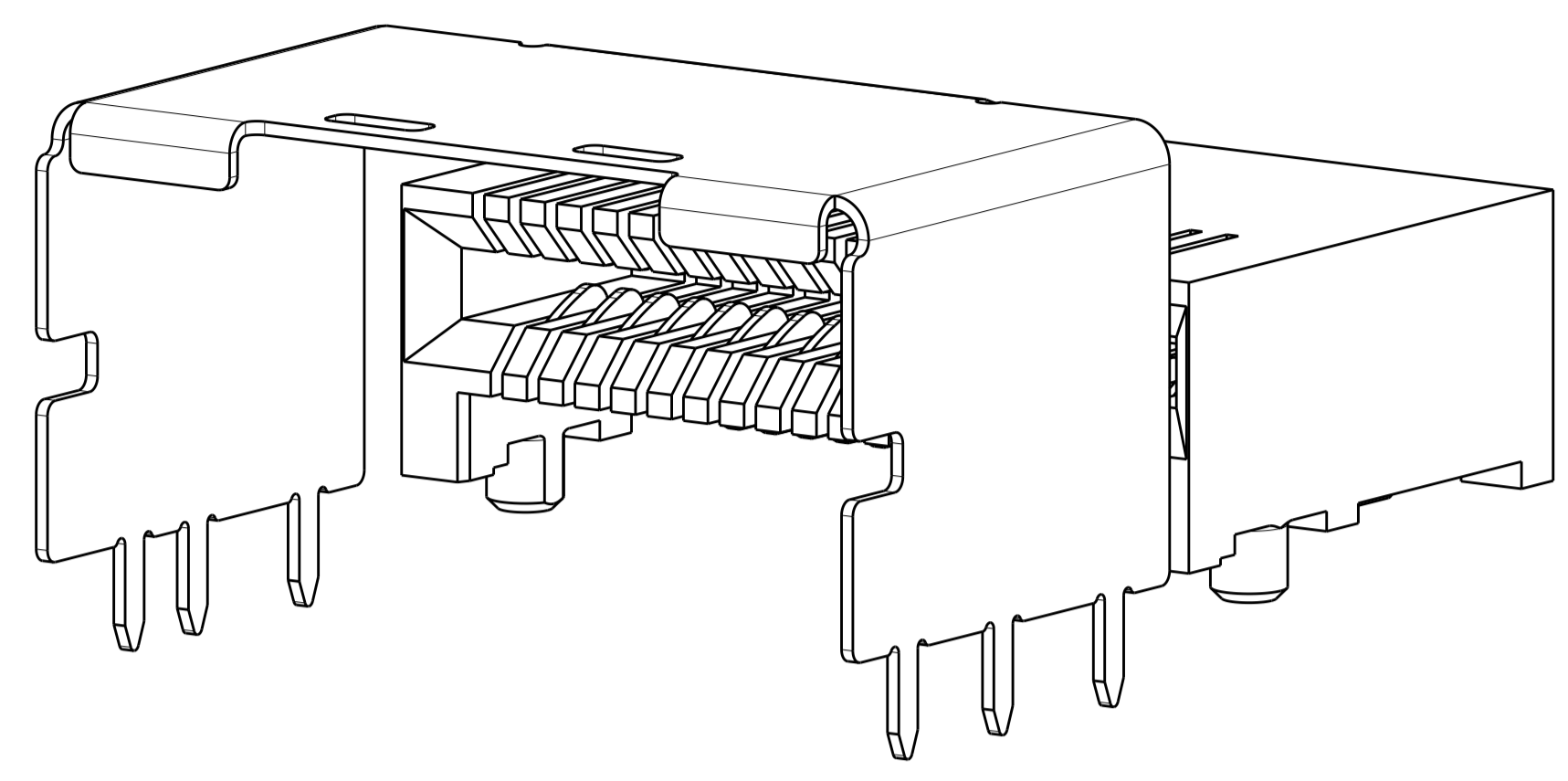

1888019-2  
 SHOWN WITHOUT PICK AND PLACE DEVICE  
 SCALE 8:1

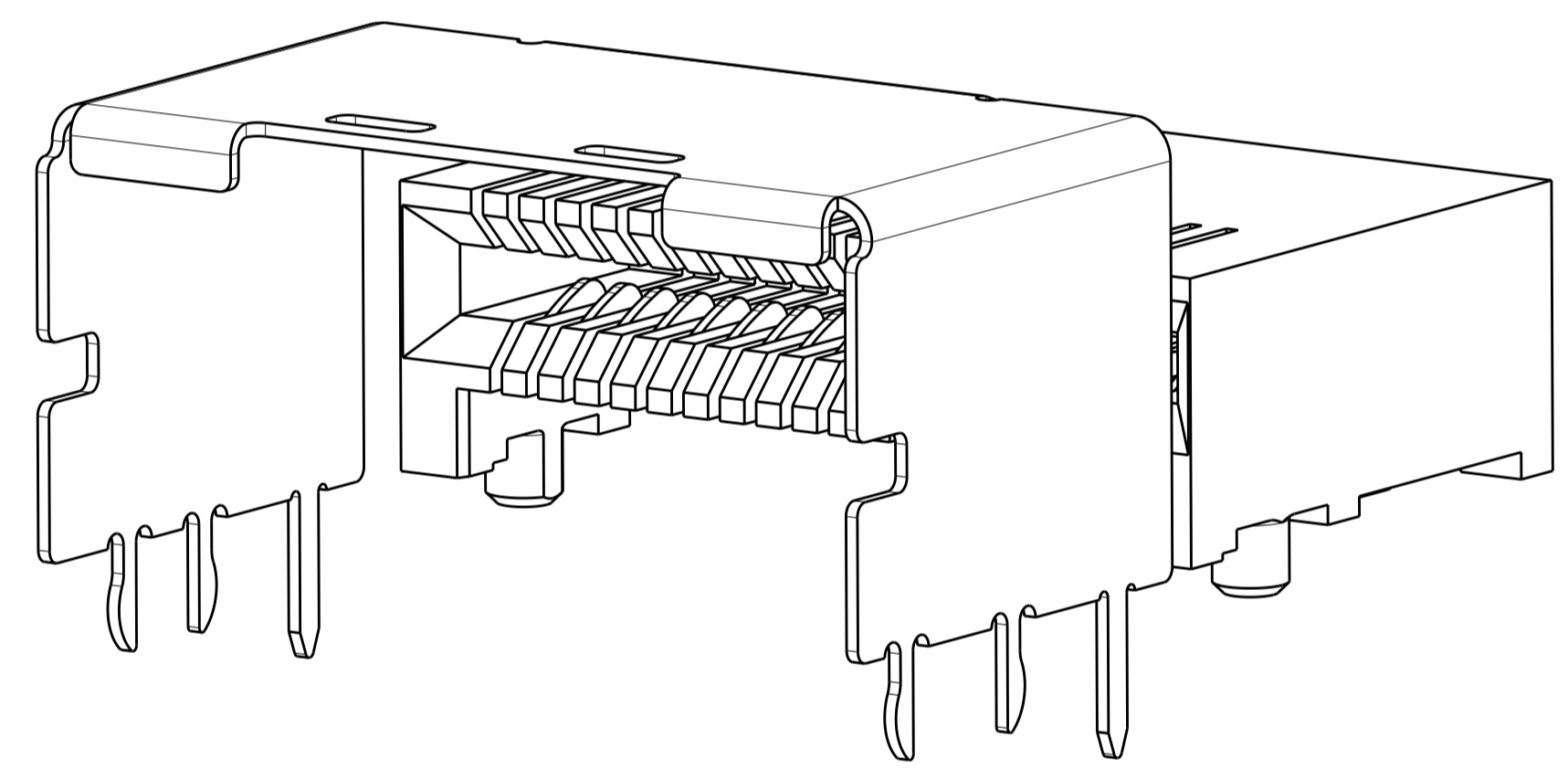

1888019-4  
 SHOWN WITHOUT PICK AND PLACE DEVICE  
 SCALE 8:1

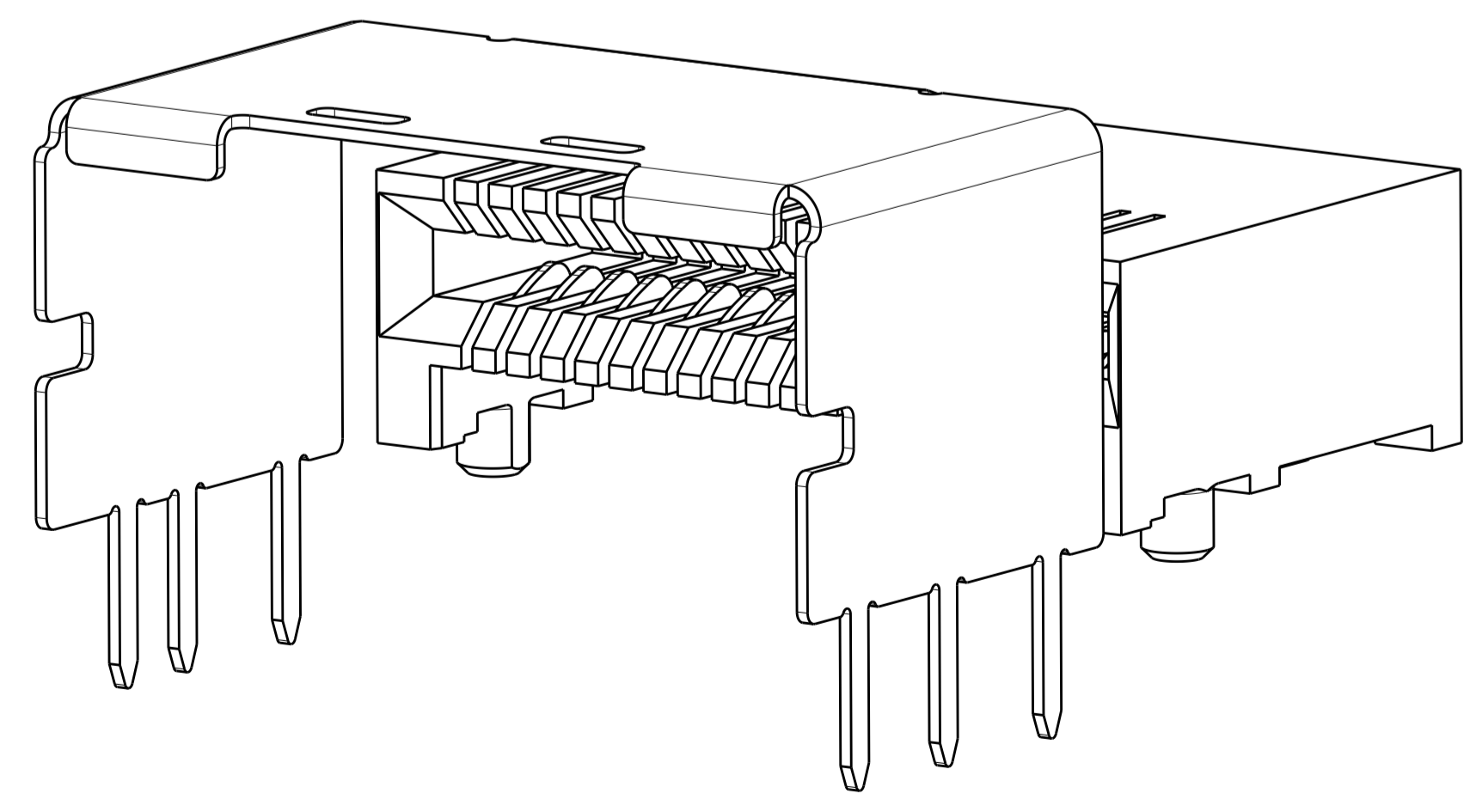

1888019-8  
 SHOWN WITHOUT PICK AND PLACE DEVICE  
 SCALE 8:1

- 1 MATERIAL: LCP, BLACK, UL94 V0.
- 2 MATERIAL: PHOSPHOR BRONZE PER ASTM B 103.
- 3 FINISH: 0.76µm MIN GOLD PLATE PER ASTM B 488, APPLIES TO INTERFACE AREA AND 2.03µm MIN TIN PLATE SOLDER TAILS, ALL OVER 3.81µm MIN NICKEL PLATE PER QQ-N-290.
- 4 MATERIAL: NICKEL-SILVER PER ASTM B 122.
- 5 DATUM AND BASIC DIMENSION ESTABLISHED BY CUSTOMER.
- 6. REFER TO CUSTOMER DRAWING 1761987 FOR CONNECTOR DETAILS.
- 7. PACKAGED IN TAPE AND REEL PER EIA-481.
- 8 FINISH: 0.38µm MIN GOLD PLATE PER ASTM B 488, APPLIES TO INTERFACE AREA AND 2.03µm MIN TIN PLATE SOLDER TAILS, ALL OVER 3.81µm MIN NICKEL PLATE PER QQ-N-290.
- 9 CUSTOMIZED PACKAGE SPEC FOR 1-1888019-3 AND 1-1888019-4

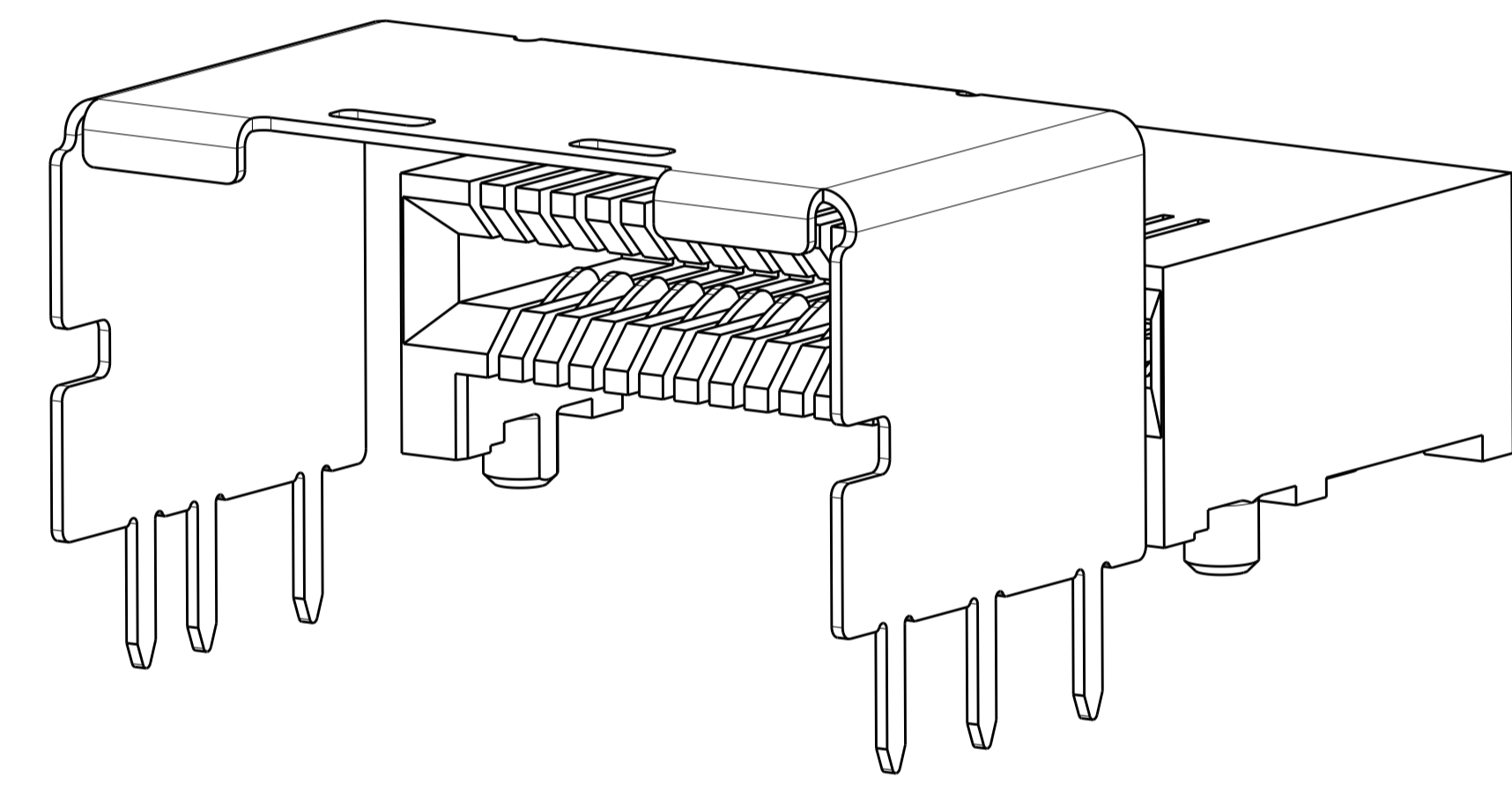

1888019-6, 1-1888019-3 AND 1-1888019-4  
 SHOWN WITHOUT PICK AND PLACE DEVICE  
 SCALE 8:1

|        |            |     |      |    |    |    |       |      |               |
|--------|------------|-----|------|----|----|----|-------|------|---------------|
| 8      | THRU HOLE  | 3.5 | 17.8 | 16 | 16 | 36 | 18.05 | 36   | 1-1888019-2   |
|        | THRU HOLE  | 2.8 | 17.8 | 16 | 16 | 36 | 18.05 | 36   | 1-1888019-1   |
|        | PRESS FIT  | -   | 17.8 | 16 | 16 | 36 | 18.05 | 36   | 1-1888019-0   |
| 3      | THRU HOLE  | 2   | 17.8 | 16 | 16 | 36 | 18.05 | 36   | 1888019-9     |
|        | THRU HOLE  | 2.8 | 17.8 | 16 | 16 | 36 | 18.05 | 36   | 1-1888019-4 9 |
|        | THRU HOLE  | 2.8 | 17.8 | 16 | 16 | 36 | 18.05 | 36   | 1-1888019-3 9 |
|        | THRU HOLE  | 3.5 | 17.8 | 16 | 16 | 36 | 18.05 | 36   | 1888019-8     |
|        | THRU HOLE  | 2.8 | 17.8 | 16 | 16 | 36 | 18.05 | 36   | 1888019-6     |
|        | PRESS FIT  | -   | 17.8 | 16 | 16 | 36 | 18.05 | 36   | 1888019-4     |
|        | THRU HOLE  | 2   | 17.8 | 16 | 16 | 36 | 18.05 | 36   | 1888019-2     |
| FINISH | SHELL TYPE | G   | E    | D  | C  | B  | A     | POSN | PART NUMBER   |

THIS DRAWING IS A CONTROLLED DOCUMENT. DWN M.E. CONNER 18JUL2005  
 CHK R.R. HENRY 18JUL2005  
 APVD R.R. HENRY 18JUL2005

**STE** TE Connectivity

NAME EVERCLEAR Mini-SAS RIGHT ANGLE INTERNAL RECEPTACLE ASSEMBLY WITH DUAL KEYED SHELL

PRODUCT SPEC 108-2234  
 APPLICATION SPEC

SIZE A1 CAGE CODE 00779 DRAWING NO. 1888019  
 WEIGHT CUSTOMER DRAWING

SCALE 8:1 SHEET 1 OF 4 REV B4

| LOC |    | DIST |     | REVISONS    |      |     |      |
|-----|----|------|-----|-------------|------|-----|------|
| GP  | 00 | P    | LTN | DESCRIPTION | DATE | DMN | APVD |
|     |    | -    |     | SEE SHEET 1 |      |     |      |

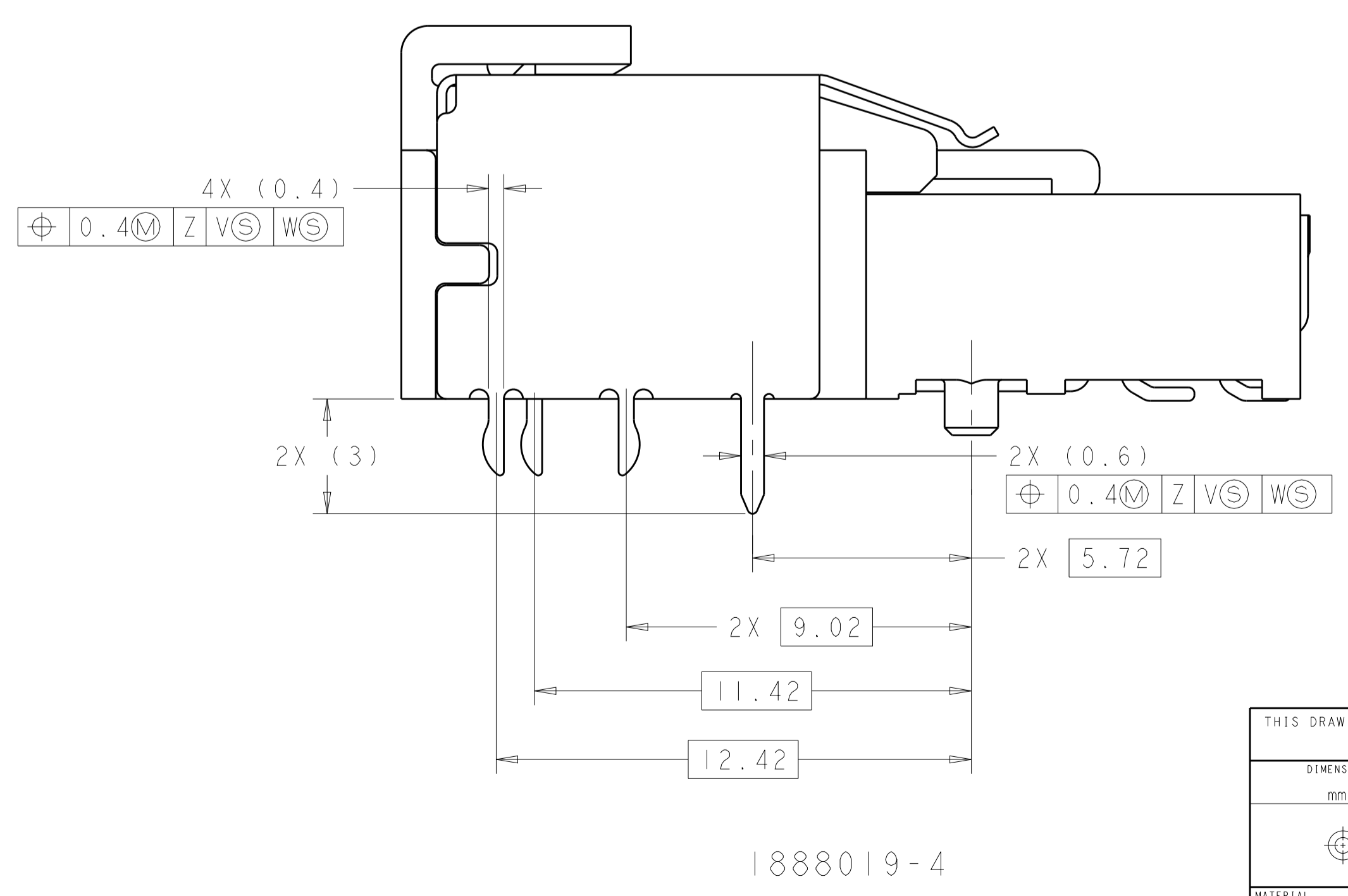
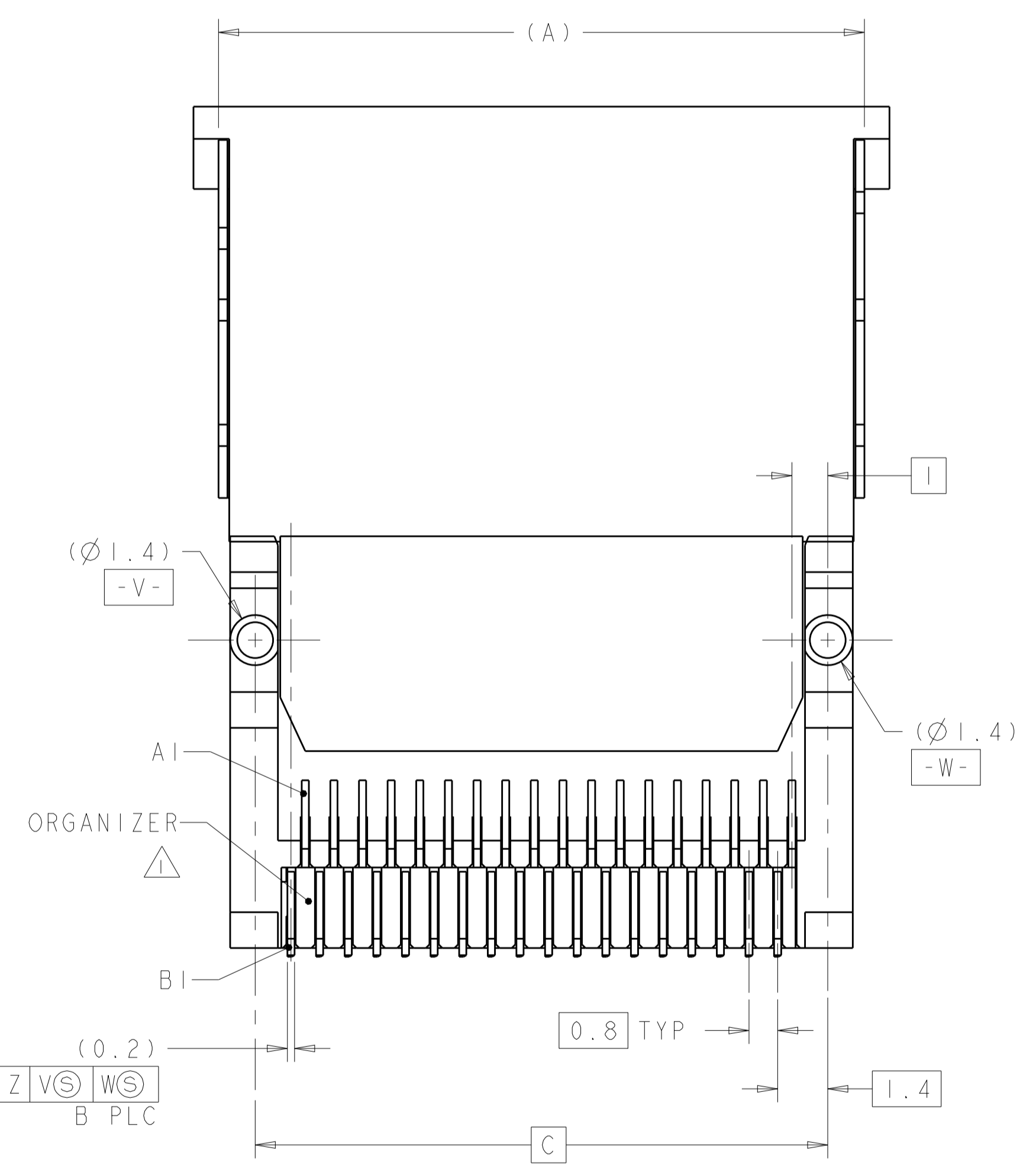
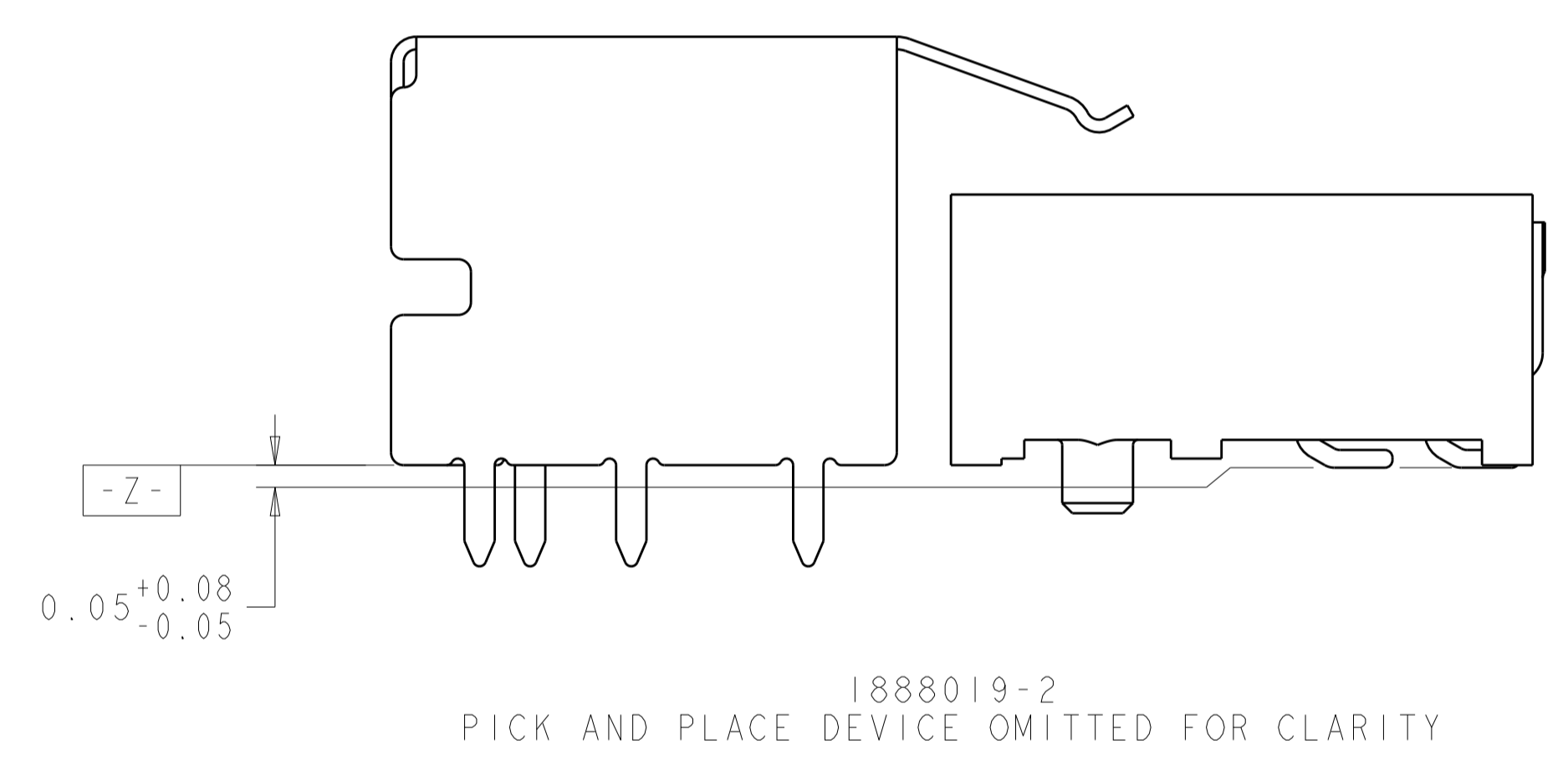
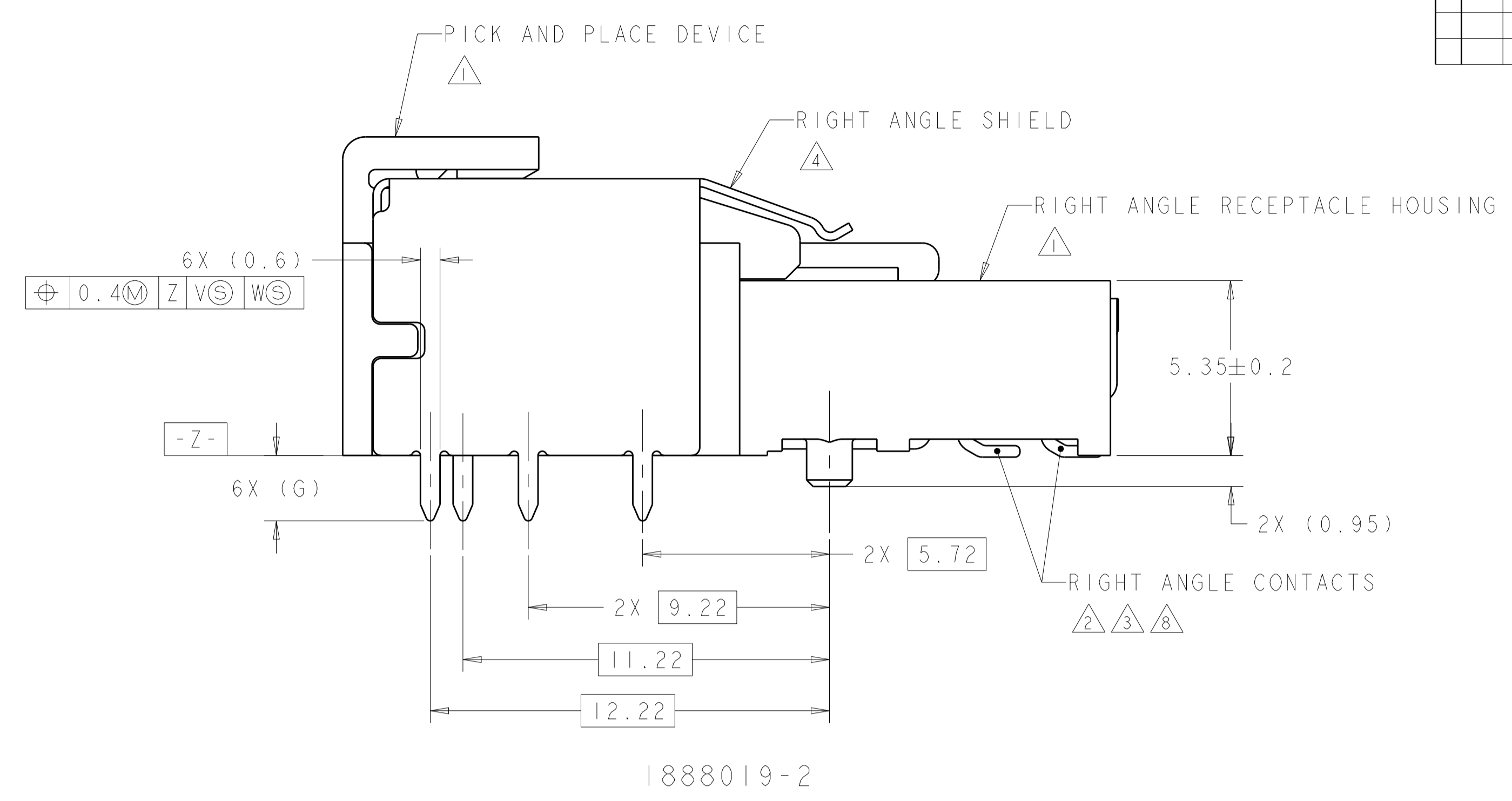
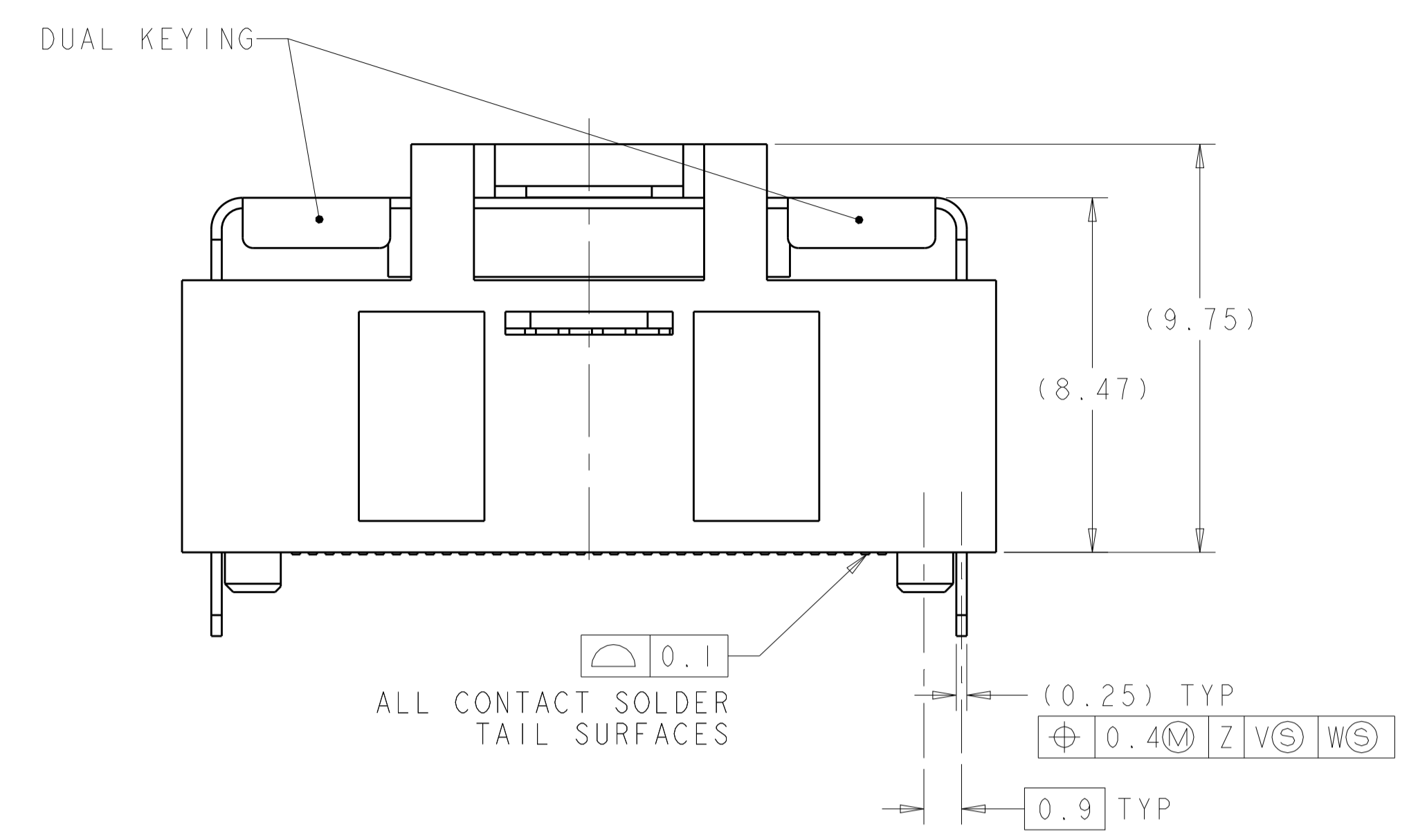

|  |                  |                           |   |
|--|------------------|---------------------------|---|
| THIS DRAWING IS A CONTROLLED DOCUMENT. |                  | DMN M.E. CONNER 18JUL2005 | TE Connectivity   |
| DIMENSIONS: mm                         |                  | CHK R.R. HENRY 18JUL2005  |   |
| TOLERANCES UNLESS OTHERWISE SPECIFIED: |                  | APVD R.R. HENRY 18JUL2005 | NAME  |
| 0 PLC ±                                | 1 PLC ±          | PRODUCT SPEC              | EVERCLEAR Mini-SAS RIGHT ANGLE INTERNAL RECEPTACLE ASSEMBLY WITH DUAL KEYED SHELL |
| 2 PLC ±                                | 3 PLC ±          | APPLICATION SPEC          | SIZE CAGE CODE DRAWING NO RESTRICTED TO   |
| 4 PLC ±                                | ANGLES ±         | WEIGHT                    | A100779C=1888019  |
| MATERIAL SEE NOTES                     | FINISH SEE TABLE | CUSTOMER DRAWING          | SCALE 8:1 SHEET 2 OF 4 REV B4   |

| LOC |    | DIST |     | REVISIONS   |      |     |      |
|-----|----|------|-----|-------------|------|-----|------|
| GP  | 00 | P    | LTN | DESCRIPTION | DATE | DMN | APVD |
|     |    | -    |     | SEE SHEET 1 |      |     |      |

1-1888019-4 AS SHOWN

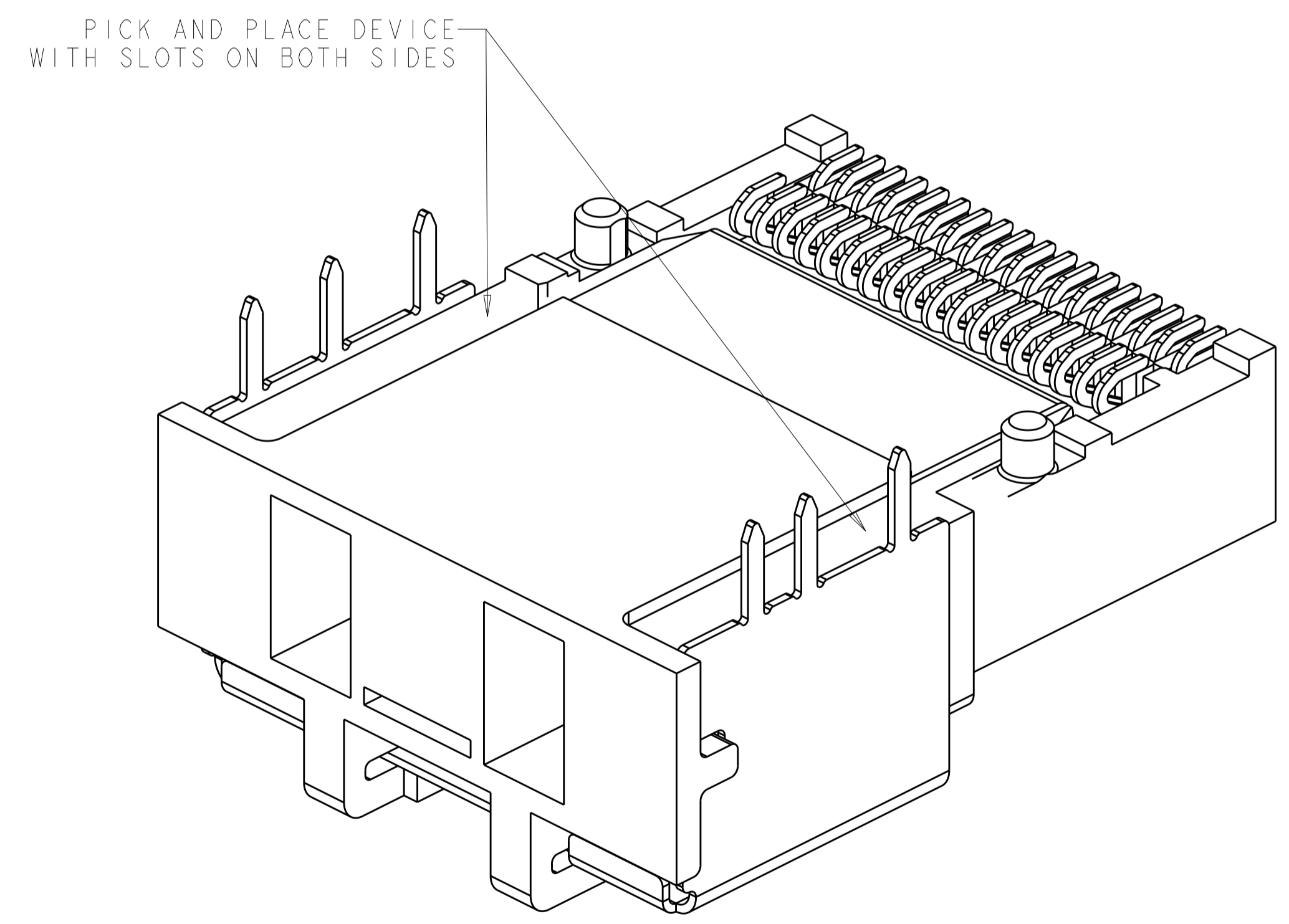
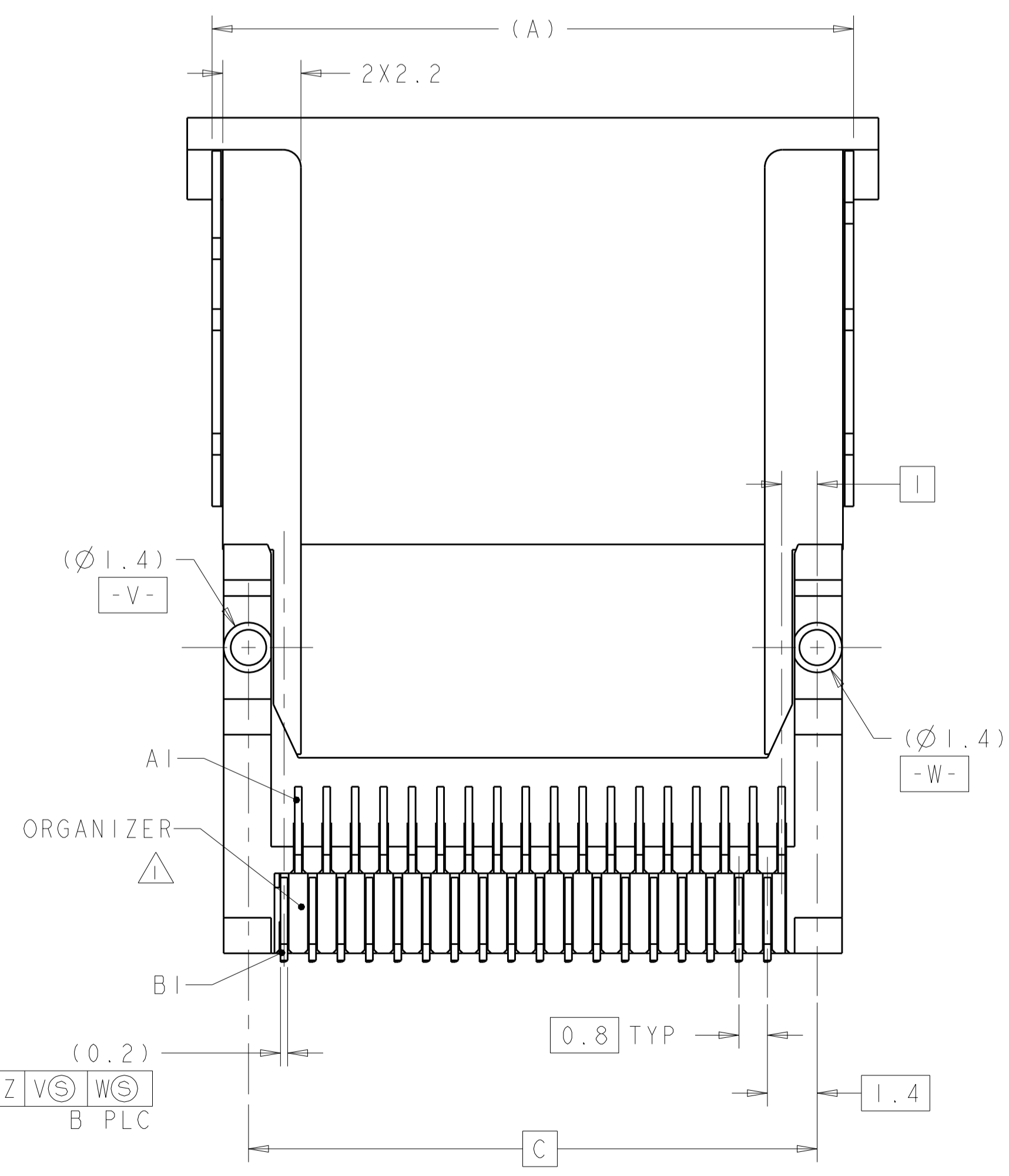
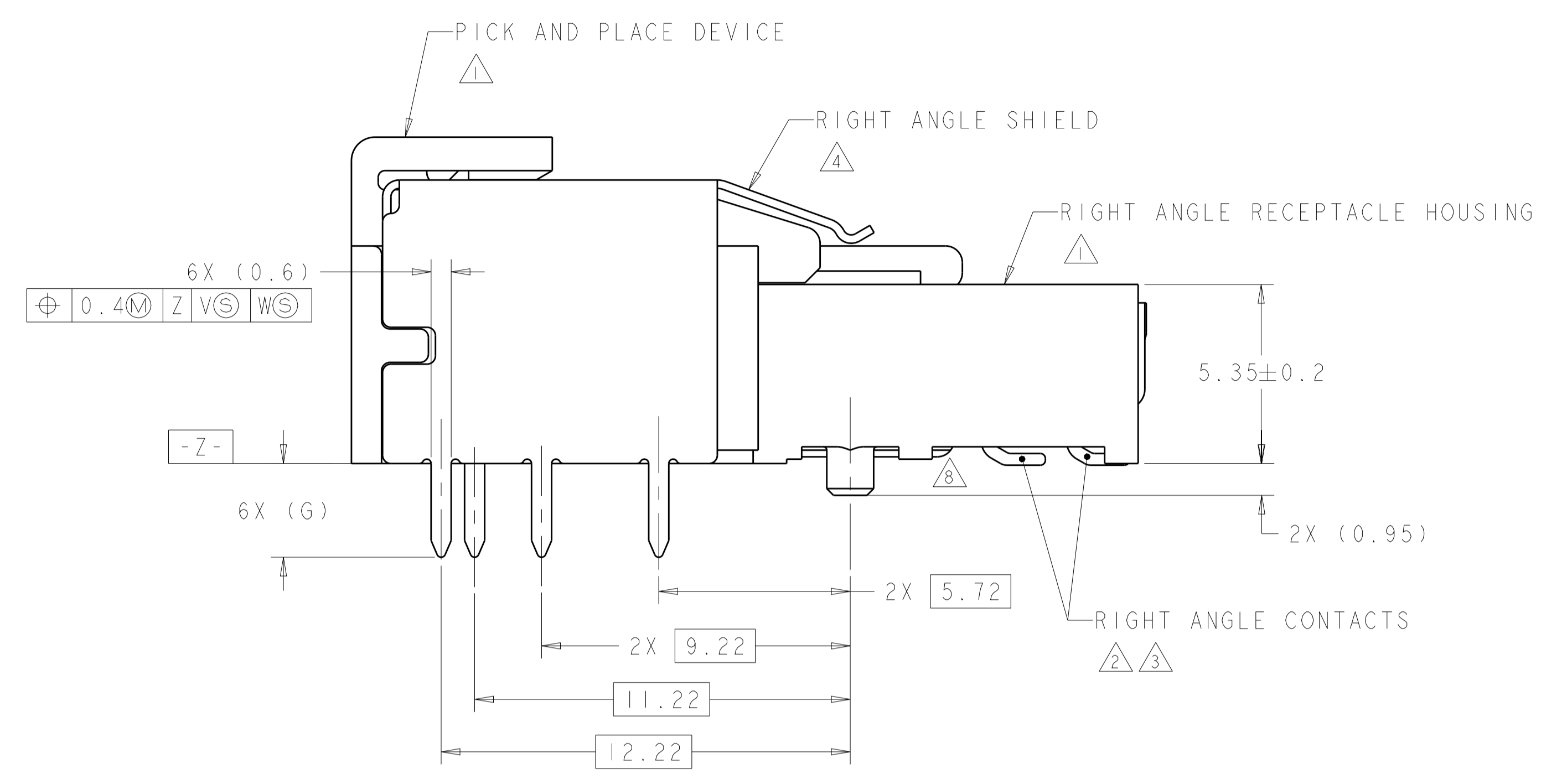
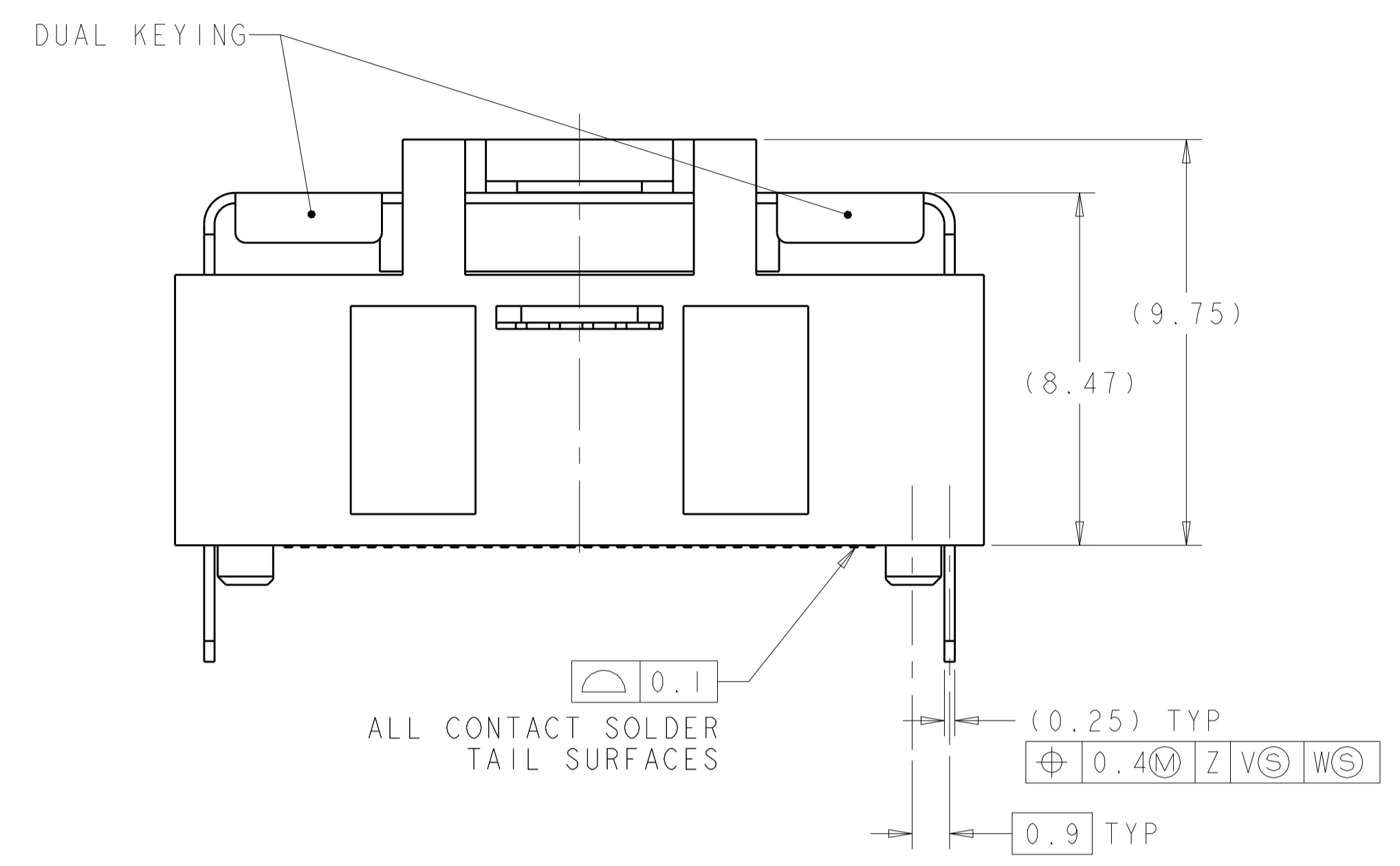

1-1888019-4  
 SCALE 8:1

|   |                   |  |   |
|---|-------------------|--|---|
| THIS DRAWING IS A CONTROLLED DOCUMENT.                          |                   | DMN: M. E. CONNER 18JUL2005  | TE Connectivity   |
| DIMENSIONS: mm  |                   | CHK: R. R. HENRY 18JUL2005   |   |
| TOLERANCES UNLESS OTHERWISE SPECIFIED:                          |                   | APVD: R. R. HENRY 18JUL2005  |   |
| 0 PLC ±<br>1 PLC ±<br>2 PLC ±<br>3 PLC ±<br>4 PLC ±<br>ANGLES ± |                   | NAME: EVERCLEAR Mini-SAS RIGHT ANGLE INTERNAL RECEPTACLE ASSEMBLY WITH DUAL KEYED SHELL<br>PRODUCT SPEC: 108-2234<br>APPLICATION SPEC: |   |
| MATERIAL: SEE NOTES   | FINISH: SEE TABLE | WEIGHT: -  | SIZE: A1<br>CAGE CODE: 00779<br>DRAWING NO: C=1888019<br>CUSTOMER DRAWING |
|   |                   | SCALE: 8:1   | SHEET: 3 OF 4<br>REV: B4  |

| LOC | DIST | REVISIONS   |      |    |      |
|-----|------|-------------|------|----|------|
| GP  | 00   | REV         | DATE | BY | APPD |
| -   | -    | SEE SHEET 1 | -    | -  | -    |
|     |      |             |      |    |      |
|     |      |             |      |    |      |

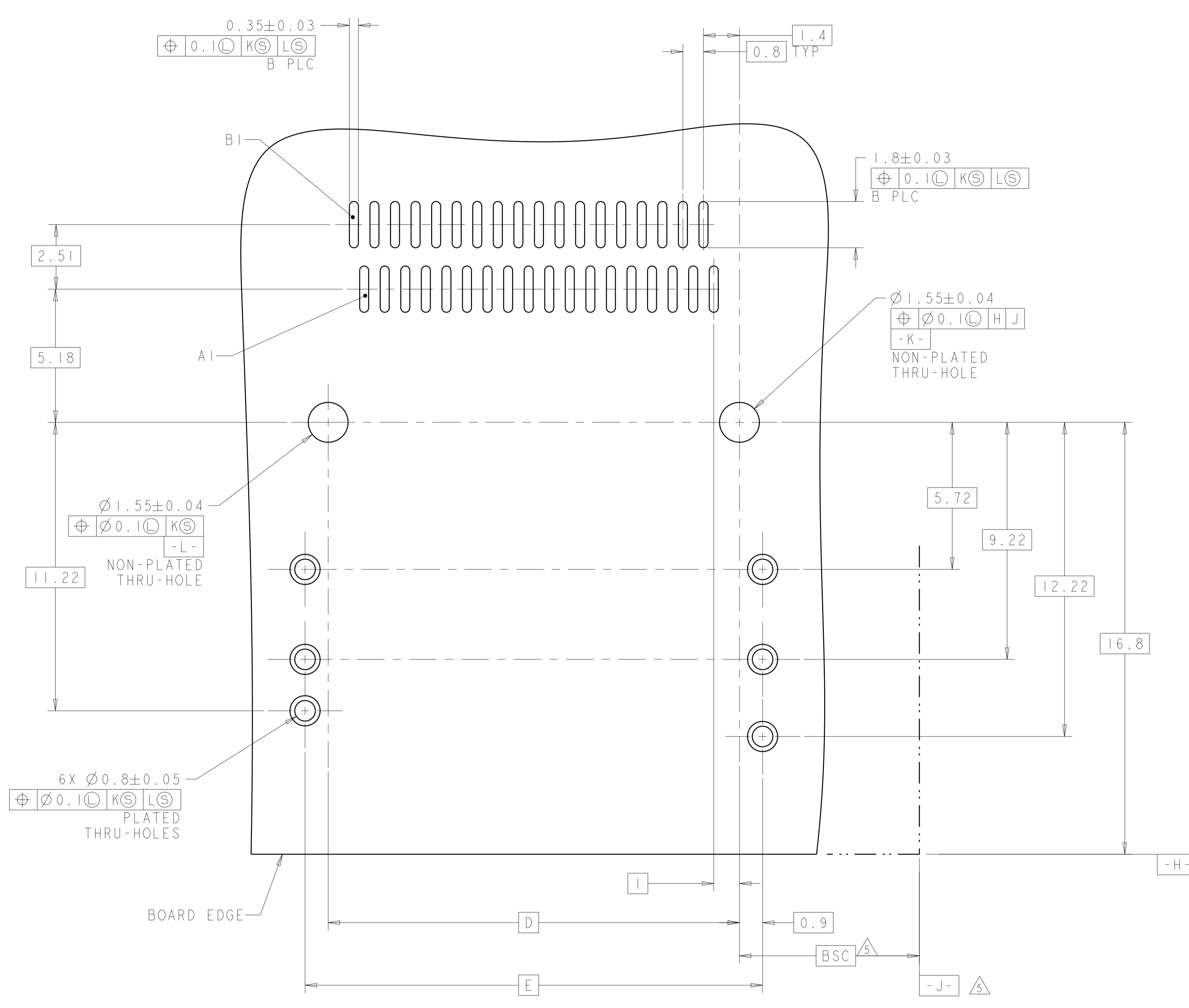

RECOMMENDED PCB LAYOUT  
 SCALE 10:1

|  |  |   |  |
|--|--|---|--|
| THIS DRAWING IS A CONTROLLED DOCUMENT. |  | DWN M. E. CONNER 18JUL2005<br>CHK R. R. HENRY 18JUL2005<br>APVD R. R. HENRY 18JUL2005           | TE Connectivity  |
| DIMENSIONS:<br>mm                      | TOLERANCES UNLESS OTHERWISE SPECIFIED:<br>0 PLC ±<br>2 PLC ±<br>3 PLC ±<br>4 PLC ±<br>ANGLES ± | NAME<br>EVERCLEAR Mini-SAS RIGHT ANGLE<br>INTERNAL RECEPTACLE ASSEMBLY<br>WITH DUAL KEYED SHELL |  |
| MATERIAL SEE NOTES                     | FINISH SEE TABLE   | PRODUCT SPEC 108-2234<br>APPLICATION SPEC<br>WEIGHT<br>CUSTOMER DRAWING                         | SIZE CAGE CODE DRAWING NO RESTRICTED TO<br>A100779C=1888019<br>SCALE 8:1 SHEET 4 OF 4 REV B4 |