

DO NOT SCALE FROM THIS PRINT

QSH-XXX-XX-X-D-DP-XXX-X-XX

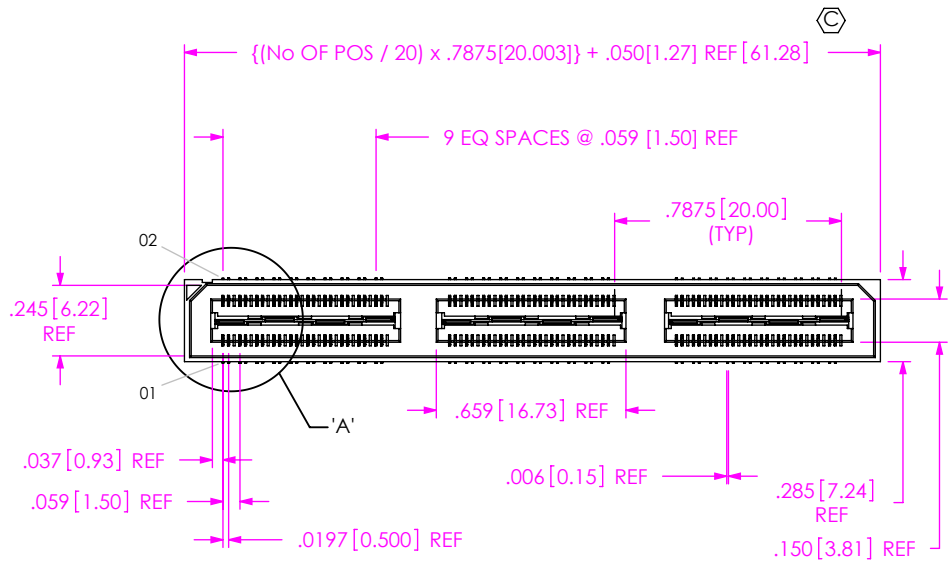

No OF POSITIONS
 -020, -040, -060,
 **-.080, **-.100
 (PER ROW)

LEAD STYLE
 -01: .1280 [3.251]

PLATING SPECIFICATION
 (SEE NOTE 11)
 -F: 3µ" FLASH SELECTIVE IN CONTACT AREA, MATTE TIN ON TAIL (USE T-1G2-01-F) (SEE NOTE 9)
 -L: 10µ" LIGHT SELECTIVE GOLD IN CONTACT AREA, MATTE TIN ON TAIL (USE T-1G2-01-L) (SEE NOTE 9)
 -H: 30µ" HEAVY GOLD IN CONTACT AREA, 3µ" GOLD ON TAIL (USE T-1G2-01-G)
 -C: 50µ" ELECTRO-POLISHED SELECTIVE GOLD IN CONTACT AREA, MATTE TIN ON TAIL (USE T-1G2-01-L) (SEE NOTE 9)

ROW SPECIFICATION
 -D: DOUBLE (USE QSH-30-01-D-XX)

DIFFERENTIAL PAIRS
 No OF BANKS

PACKAGING
 BLANK: TRAY (SEE NOTES 13 & 14)
 -TR: TAPE & REEL (SEE NOTES 14 & 15) (60 POS MAX)
 -FR: FULL REEL QTY TAPE & REEL (SEE NOTES 14 & 15) (60 POS MAX)

PICK & PLACE OPTION
 -K: POLYIMIDE FILM (USE K-DOT-.325-.450-.005, SEE FIG 3, SHT 2)

OPTIONS
 -A: ALIGNMENT PINS (USE QSH-30-01-D-XX-A) (SEE FIG 2, SHT 2)
 -GP: GUIDE POSTS (USE QSH-30-01-D-XX-GP) (SEE FIG 4, SHT 3)
 -LC: LOCKING CLIPS (SEE NOTE 12) (USE LC-08-TM-01, SEE FIG 1)
 -FL: FRICTION LOCKS (SEE FIG 5, SHT 3) (NOT AVAILABLE WITH -GP)
 -RT1: RETENTION (MUST USE -A OPTION) (USE QSH-30-01-D-XX-A-RT1 & SUB-SC-05-01-FF) (SEE FIG 6, SHT 3) (NOT AVAILABLE WITH -LC, -GP, OR -FL) (NOT AVAILABLE WITH -080 & -100 POS)
 -L: LATCHING (SEE FIG 7, SHT 4) (USE QSH-30-01-D-XX-A-L) (MUST SELECT -A, NOT AVAILABLE WITH OTHER OPTIONS)

C-126-01-X CAN BE SUBBED FOR C-126-21-X
 ** = SEE NOTE 10

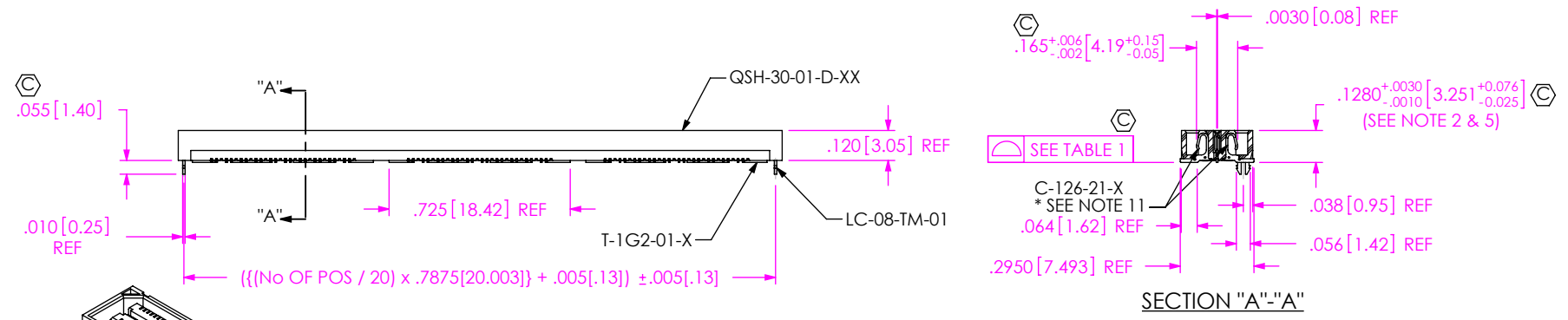

FIG 1
 -LC: LOCKING CLIP OPTION SHOWN

NOTES:

- ⊕ REPRESENTS A CRITICAL DIMENSION.
- MAXIMUM VARIANCE: .002 [0.05]
- MAXIMUM BURR ALLOWANCE: .0015 [0.038]
- MINIMUM PUSHOUT FORCE: 4 OZ
- DIMENSION APPLIES TO GROUND PLANE AND CONTACT.
- MINIMUM GROUND PLANE RETENTION: 8 OZ
- L PLATING CAN BE SUBSTITUTED FOR -F PLATING.
- SUB-SC-05-01-XX RETENTION TO BE 1.0 LBF IN BODY.
- MAY SUB C-126-01-X FOR C-126-21-X.
- FOR NEW APPLICATIONS REQUIRING THESE POSITIONS PLEASE CONTACT SAMTEC INTERCONNECT PROCESSING GROUP.
- FOR -80, -100 POSITIONS USE C-269-11-X. DO NOT SUB C-126.
- DUE TO THE HIGH AMOUNT OF INSERTION FORCE NEEDED, THE -LC OPTION IS NOT COMPATIBLE WITH AUTO PLACEMENT. SAMTEC RECOMMENDS MANUAL PLACEMENT FOR ALL ASSEMBLIES WITH THE -LC OPTION."
- TRAYS ARE STANDARD PACKAGING.
- ORDERS WILL BE PACKAGED ACCORDING TO THE SAMTEC PACKAGING EFFICIENCY STANDARDS (SPES) FOUND ON WWW.SAMTEC.COM.
- ATTACH LABEL -4X2 TO EACH REEL.

TABLE 1

No OF POS	COPLANARITY (INCLUDES GROUND PLANE)
-020 THRU -060	.0040[.102]
-080 THRU -100	.0060[.152]

UNLESS OTHERWISE SPECIFIED, DIMENSIONS ARE IN INCHES. TOLERANCES ARE: DECIMALS ANGLES .XX: ±.01 [.3] ° .XXX: ±.005 [.13] ° .XXX: ±.0020 [.051] °

PROPRIETARY NOTE
 THIS DOCUMENT CONTAINS CONFIDENTIAL AND PROPRIETARY INFORMATION AND ALL DESIGN, MANUFACTURING, REPRODUCTION, USE, PATENT RIGHTS AND SALES RIGHTS ARE EXPRESSLY RESERVED BY SAMTEC, INC. THIS DOCUMENT SHALL NOT BE DISCLOSED, IN WHOLE OR PART, TO ANY UNAUTHORIZED PERSON OR ENTITY NOR REPRODUCED, TRANSFERRED OR INCORPORATED IN ANY OTHER PROJECT IN ANY MANNER WITHOUT THE EXPRESS WRITTEN CONSENT OF SAMTEC, INC.

MATERIAL: DO NOT SCALE DRAWING SHEET SCALE: 3:2
 INSULATOR: BLACK, LCP
 FLAMMABILITY RATING: UL94V0
 TERMINAL: PHOS BRONZE
 GROUND PLANE: PHOS BRONZE

DESCRIPTION: .5mm DIFFERENTIAL PAIRS HS SOCKET ASSEMBLY
 DWG. NO. QSH-XXX-XX-X-D-DP-XXX-X-XX
 BY: KEVIN B 06/13/00 SHEET 1 OF 4

520 PARK EAST BLVD, NEW ALBANY, IN 47150
 PHONE: 812-944-6733 FAX: 812-948-5047
 e-Mail: info@SAMTEC.com code 55322

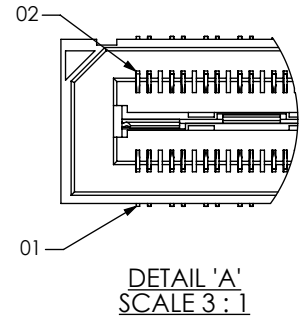
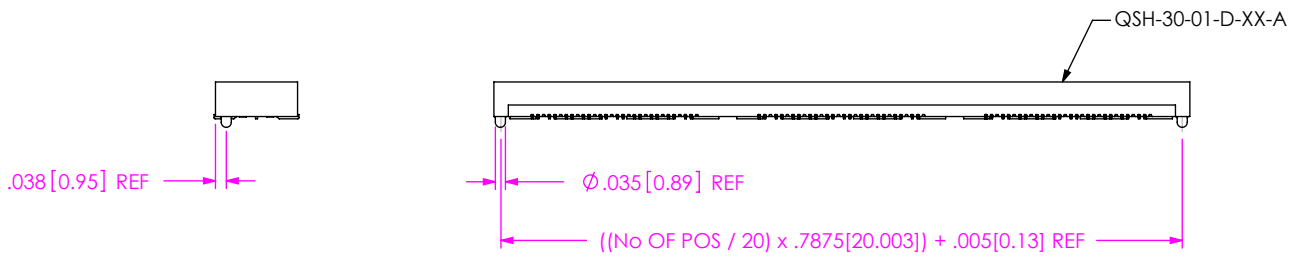

FIG 2
-A: ALIGNMENT PIN OPTION SHOWN

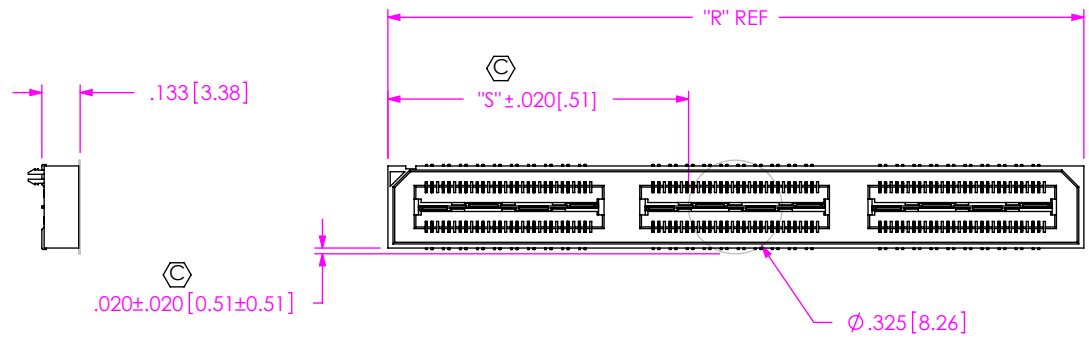



FIG 3
-K: POLYIMIDE FILM PAD

NOTE: "R" = ((No OF POSITIONS / 20) x .7875 [20.003]) + .050 [1.27]
 "S" = (("R" - .325 [8.26]) / 2) ± .020 [0.51]

<p>PROPRIETARY NOTE</p> <p>THIS DOCUMENT CONTAINS CONFIDENTIAL AND PROPRIETARY INFORMATION AND ALL DESIGN, MANUFACTURING, REPRODUCTION, USE, PATENT RIGHTS AND SALES RIGHTS ARE EXPRESSLY RESERVED BY SAMTEC, INC. THIS DOCUMENT SHALL NOT BE DISCLOSED, IN WHOLE OR PART, TO ANY UNAUTHORIZED PERSON OR ENTITY NOR REPRODUCED, TRANSFERRED OR INCORPORATED IN ANY OTHER PROJECT IN ANY MANNER WITHOUT THE EXPRESS WRITTEN CONSENT OF SAMTEC, INC.</p>	 <p>520 PARK EAST BLVD, NEW ALBANY, IN 47150 PHONE: 812-944-6733 FAX: 812-948-5047 e-Mail info@SAMTEC.com code 55322</p>
<p>DO NOT SCALE DRAWING</p>	<p>DESCRIPTION: .5mm DIFFERENTIAL PAIRS HS SOCKET ASSEMBLY</p>
<p>SHEET SCALE: 1.5:1</p>	<p>DWG. NO. QSH-XXX-XX-X-D-DP-XXX-X-XX</p>
	<p>BY: KEVIN B 06/13/00 SHEET 2 OF 4</p>

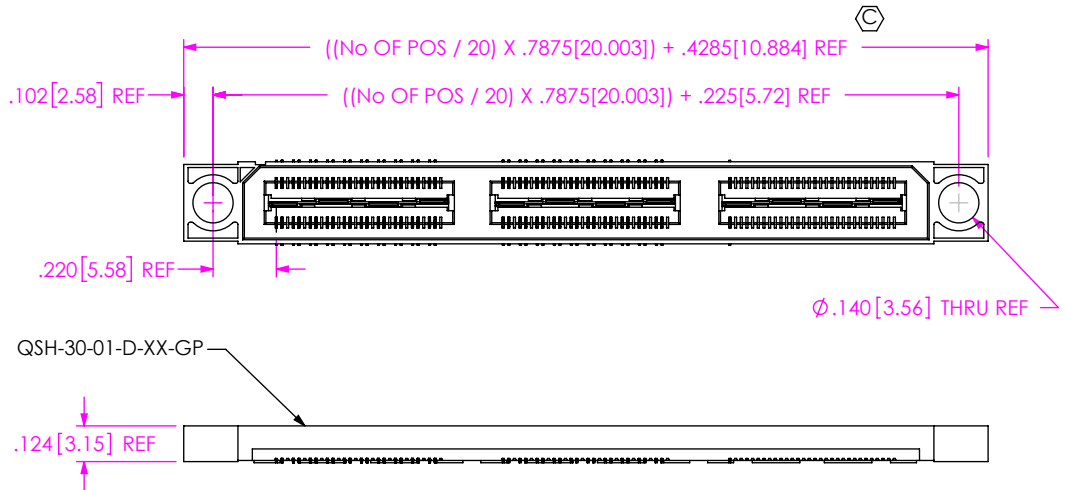
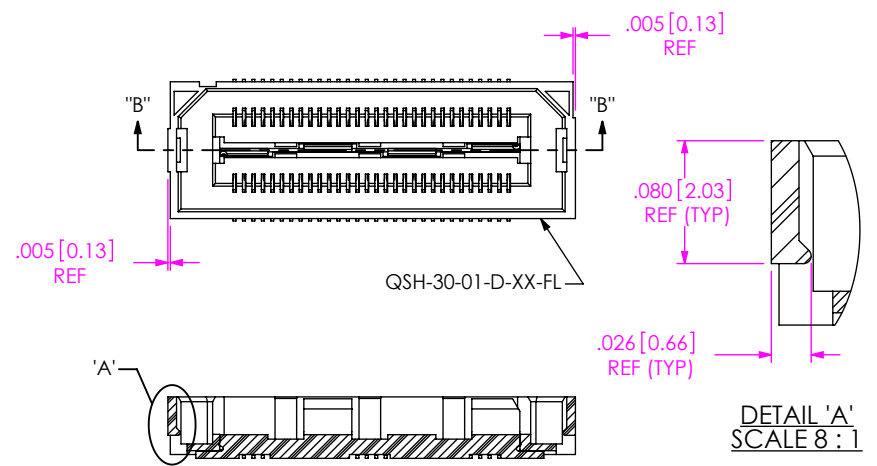
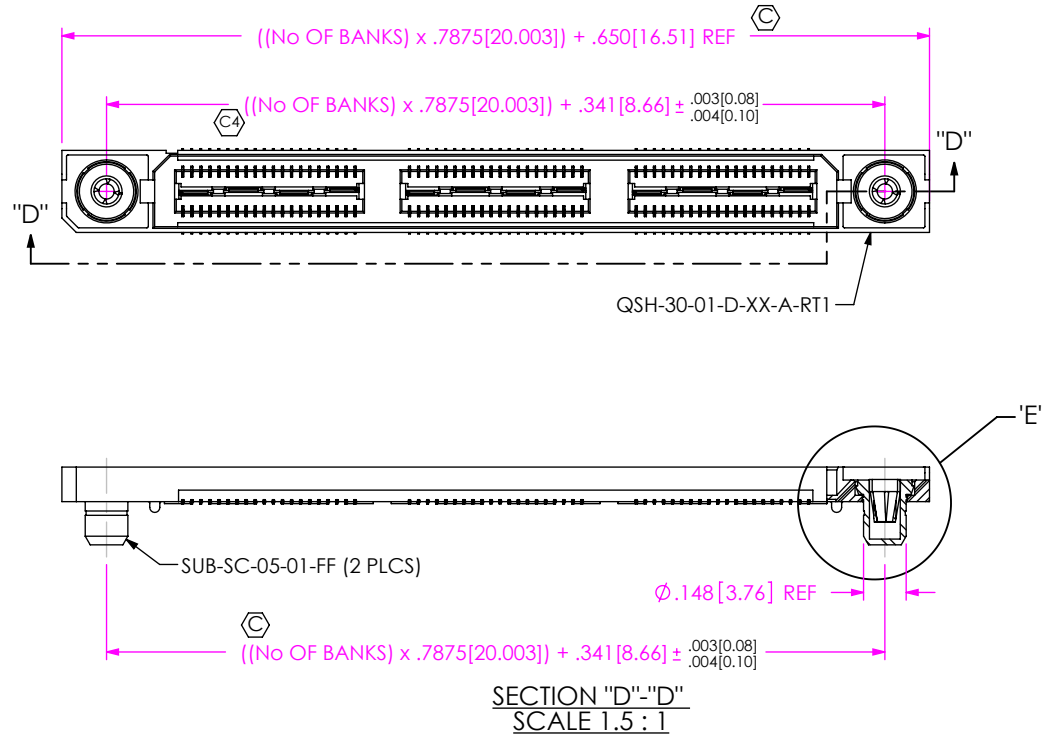

FIG 4
-GP: GUIDE POST OPTION SHOWN



SECTION "B"-"B"
FIG 5
-FL: FRICTION LOCKS
(NOT AVAILABLE WITH -GP OPTION)
(SAME AS FIG 1, UNLESS OTHERWISE STATED)



SECTION "D"-"D"
SCALE 1.5 : 1

FIG 6
-RT1: RETENTION OPTION
(MUST USE -A OPTION)
(NOT AVAILABLE WITH -LC, -GP, OR -FL OPTIONS)
(NOT AVAILABLE WITH -080 & -100 POS)
(SAME AS FIG 1, UNLESS OTHERWISE STATED)

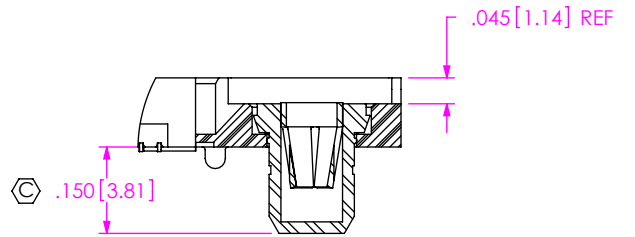

DETAIL 'E'
SCALE 3 : 1

<p>DO NOT SCALE DRAWING</p> <p>SHEET SCALE: 1.25:1</p>	<p>PROPRIETARY NOTE</p> <p>THIS DOCUMENT CONTAINS CONFIDENTIAL AND PROPRIETARY INFORMATION AND ALL DESIGN, MANUFACTURING, REPRODUCTION, USE, PATENT RIGHTS AND SALES RIGHTS ARE EXPRESSLY RESERVED BY SAMTEC, INC. THIS DOCUMENT SHALL NOT BE DISCLOSED, IN WHOLE OR PART, TO ANY UNAUTHORIZED PERSON OR ENTITY NOR REPRODUCED, TRANSFERRED OR INCORPORATED IN ANY OTHER PROJECT IN ANY MANNER WITHOUT THE EXPRESS WRITTEN CONSENT OF SAMTEC, INC.</p>	<p>samtec</p> <p>520 PARK EAST BLVD, NEW ALBANY, IN 47150 PHONE: 812-944-6733 FAX: 812-948-5047 e-Mail info@SAMTEC.com code 55322</p>
	<p>DESCRIPTION: .5mm DIFFERENTIAL PAIRS HS SOCKET ASSEMBLY</p>	
	<p>DWG. NO. QSH-XXX-XX-X-D-DP-XXX-X-XX</p>	
<p>BY: KEVIN B 06/13/00</p>	<p>SHEET 3 OF 4</p>	

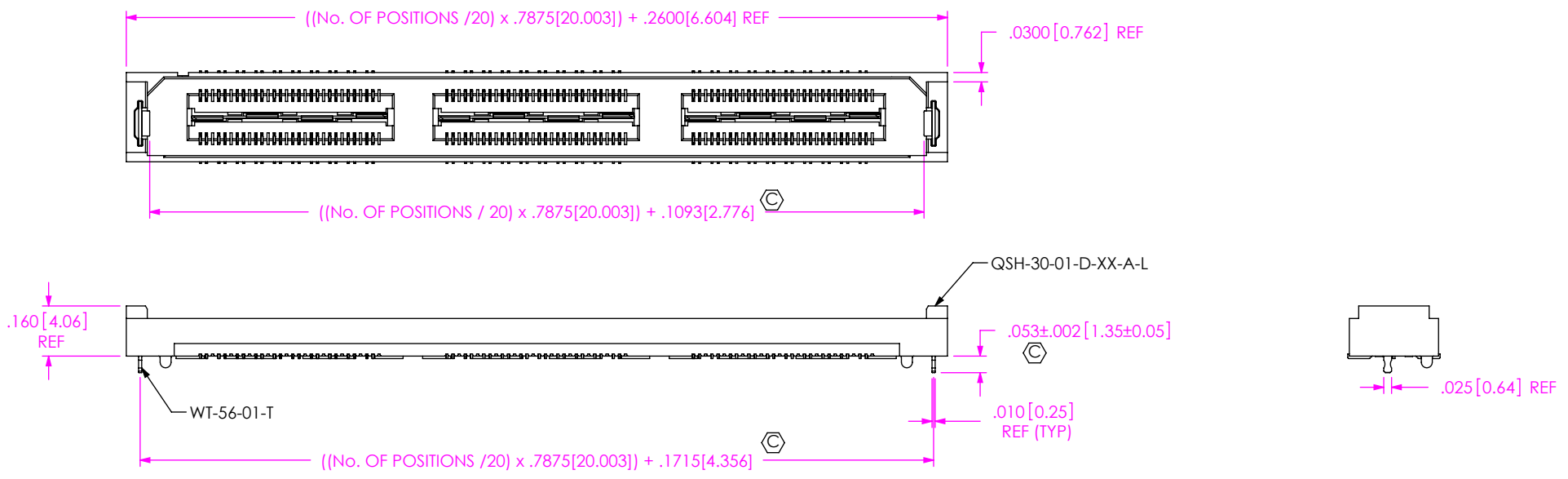

FIG 7
 -L: LATCHING OPTION
 (NOT AVAILABLE WITH -LC, -GP, -FL, OR -RT1 OPTIONS)
 (SAME AS FIG 1, UNLESS OTHERWISE STATED)

<p>• PROPRIETARY NOTE • THIS DOCUMENT CONTAINS CONFIDENTIAL AND PROPRIETARY INFORMATION AND ALL DESIGN, MANUFACTURING, REPRODUCTION, USE, PATENT RIGHTS AND SALES RIGHTS ARE EXPRESSLY RESERVED BY SAMTEC, INC. THIS DOCUMENT SHALL NOT BE DISCLOSED, IN WHOLE OR PART, TO ANY UNAUTHORIZED PERSON OR ENTITY NOR REPRODUCED, TRANSFERRED OR INCORPORATED IN ANY OTHER PROJECT IN ANY MANNER WITHOUT THE EXPRESS WRITTEN CONSENT OF SAMTEC, INC.</p>	<p>samtec 520 PARK EAST BLVD, NEW ALBANY, IN 47150 PHONE: 812-944-6733 FAX: 812-948-5047 e-Mail info@SAMTEC.com code 55322</p>
<p>DO NOT SCALE DRAWING SHEET SCALE: 2:1</p>	<p>DESCRIPTION: .5mm DIFFERENTIAL PAIRS HS SOCKET ASSEMBLY DWG. NO. QSH-XXX-XX-X-D-DP-XXX-X-XX BY: KEVIN B 06/13/00 SHEET 4 OF 4</p>