

SPECIFICATIONS

PARAMETERS	VALUES	UNITS
RESONANT FREQUENCY	2,500 ± 300	Hz
RESONANT IMPEDANCE (MAX)	500	Ohm
MAX INPUT VOLTAGE	30	Vp-p
CAPACITANCE @ 1kHz	80,000 ±30%	pF
PLATE MATERIAL	BRASS	-
OPERATING TEMPERATURE	-20 ~ +60	°C
STORAGE TEMPERATURE	-20 ~ +70	°C

THIS DOCUMENT CONTAINS DATA PROPRIETARY TO PROJECTS UNLIMITED, INC. ANY USE OR REPRODUCTION, IN ANY FORM, WITHOUT PRIOR WRITTEN PERMISSION OF PROJECTS UNLIMITED, INC. IS PROHIBITED.
©2003, Projects Unlimited Inc.

REVISION HISTORY

LTR	DESCRIPTION	DATE	APPROVED
-	RELEASED FROM ENGINEERING	11/29/2001	
A	REVISED TO NEW TEMPLATE	9/4/2003	R.W.
B	REVISED SPECIFICATIONS	1/9/2004	R.W.
C	REVISED DIMENSION SIZE AND STYLE	1/17/2006	B.R.
D	REVISED TO INVENTOR 3-D DRAWING TEMPLATE	8/10/2010	B.R.

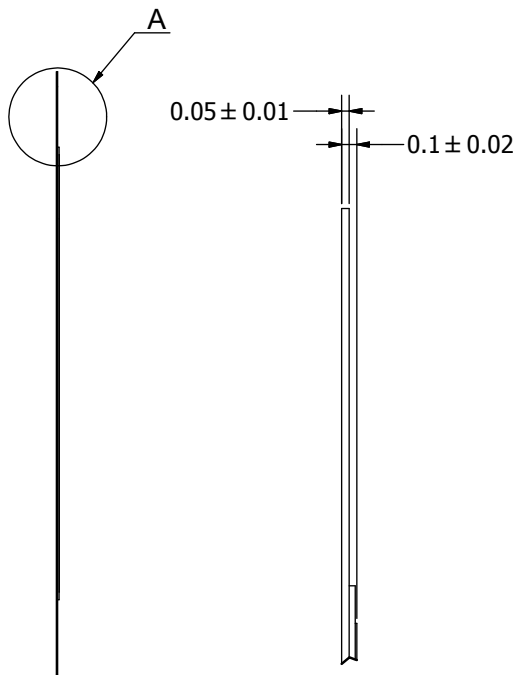
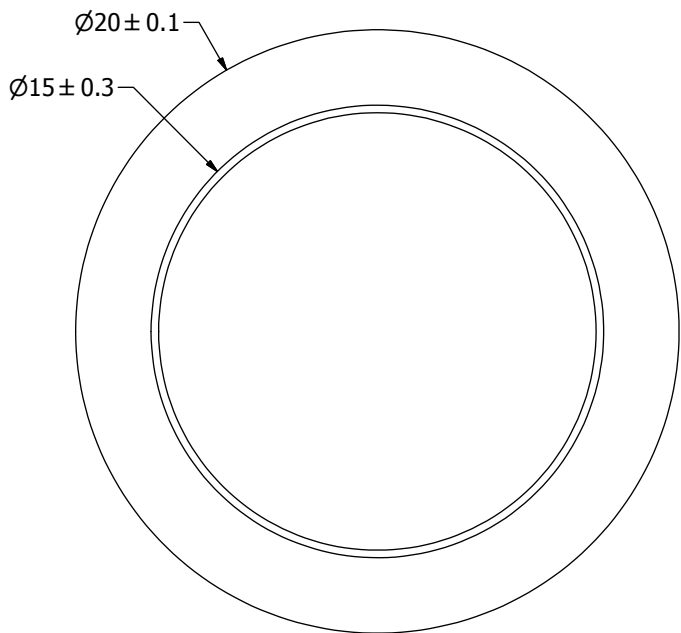

A (30 : 1)

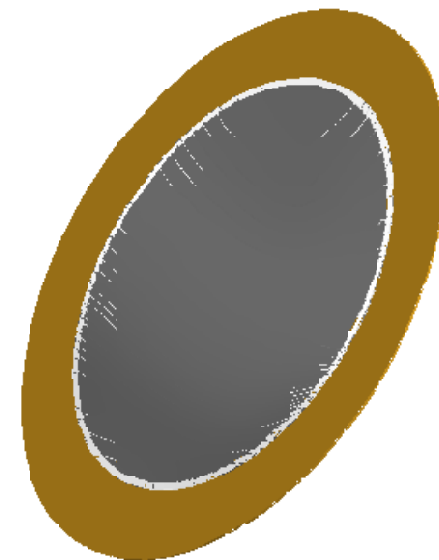

NOTES:

1. ALL DIMENSIONS ARE IN MILLIMETERS.
2. SPECIFICATIONS SUBJECT TO CHANGE OR WITHDRAWL WITHOUT NOTICE.
3. THIS PART IS RoHS 2002/95/EC COMPLIANT.

UNLESS OTHERWISE SPECIFIED: DIMENSIONS ARE IN MILLIMETERS, TOLERANCES ARE ±0.5 AND ANGLES ARE ±3°.	SIZE	Designed by	Date	Checked by	Date	Approved by	Date	Drawn Date	
	A3	RABL	11/29/2001			S.J.	11/30/2001	8/10/2010	
AB2025B.idw	 pui audio a projects unlimited company		AB2025B			Bender		Edition -	Sheet 1 / 1