

## 4-Bit Parallel-In/Parallel-Out Shift Register

The MC14035B 4-bit shift register is constructed with MOS P-channel and N-channel enhancement mode devices in a single monolithic structure. It consists of a 4-stage clocked serial-shift register with synchronous parallel inputs and buffered parallel outputs. The Parallel/Serial (P/S) input allows serial-right shifting of data or synchronous parallel loading via inputs DP0 thru DP3. The True/Complement (T/C) input determines whether the outputs display the Q or  $\bar{Q}$  outputs of the flip-flop stages. J-K logic forms the serial input to the first stage. With the J and K inputs connected together they operate as a serial "D" input.

This device may be effectively used for shift-right/shift-left registers, parallel-to-serial/serial-to-parallel conversion, sequence generation, up/down Johnson or ring counters, pseudo-random code generation, frequency and phase comparators, sample and hold registers, etc . . .

- 4-Stage Clocked Serial-Shift Operation
- Synchronous Parallel Loading of all Four Stages
- J-K Serial Inputs on First Stage
- Asynchronous True/Complement Control of all Outputs
- Fully Static Operation
- Asynchronous Master Reset
- Data Transfer Occurs on the Positive-Going Clock Transition
- No Limit on Clock Rise and Fall Times
- All Inputs are Buffered
- Supply Voltage Range = 3.0 Vdc to 18 Vdc
- Capable of Driving Two Low-power TTL Loads or One Low-power Schottky TTL Load Over the Rated Temperature Range

### MAXIMUM RATINGS\* (Voltages Referenced to V<sub>SS</sub>)

Symbol	Parameter	Value	Unit
V <sub>DD</sub>	DC Supply Voltage	- 0.5 to + 18.0	V
V <sub>in</sub> , V <sub>out</sub>	Input or Output Voltage (DC or Transient)	- 0.5 to V <sub>DD</sub> + 0.5	V
I <sub>in</sub> , I <sub>out</sub>	Input or Output Current (DC or Transient), per Pin	± 10	mA
P <sub>D</sub>	Power Dissipation, per Package†	500	mW
T <sub>stg</sub>	Storage Temperature	- 65 to + 150	°C
T <sub>L</sub>	Lead Temperature (8-Second Soldering)	260	°C

\* Maximum Ratings are those values beyond which damage to the device may occur.

† Temperature Derating:

Plastic "P and D/DW" Packages: - 7.0 mW/°C From 65°C To 125°C

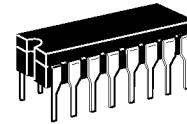
Ceramic "L" Packages: - 12 mW/°C From 100°C To 125°C

### TRUTH TABLE

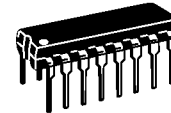
Inputs				t <sub>n</sub> Output Q <sub>0</sub>
C	J	$\bar{K}$	R	
$\swarrow$	0	0	0	0
$\swarrow$	0	1	0	Q <sub>0</sub> (n - 1)
$\swarrow$	1	0	0	Q <sub>0</sub> (n - 1)
$\swarrow$	1	1	0	1
$\searrow$	X	X	0	Q <sub>0</sub> (n - 1)
X	X	X	1	0

X = Don't Care  
P/S = 0 = Serial Mode  
T/C = 1 = True Outputs

## MC14035B



**L SUFFIX**  
CERAMIC  
CASE 620



**P SUFFIX**  
PLASTIC  
CASE 648



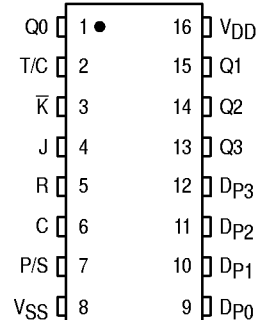
**D SUFFIX**  
SOIC  
CASE 751B

### ORDERING INFORMATION

MC14XXXBCP Plastic  
MC14XXXBCL Ceramic  
MC14XXXBD SOIC

T<sub>A</sub> = - 55° to 125°C for all packages.

### PIN ASSIGNMENT



**ELECTRICAL CHARACTERISTICS** (Voltages Referenced to  $V_{SS}$ )

Characteristic	Symbol	$V_{DD}$ Vdc	-55°C		25°C			125°C		Unit
			Min	Max	Min	Typ #	Max	Min	Max	
Output Voltage $V_{in} = V_{DD}$ or 0  $V_{in} = 0$ or $V_{DD}$	"0" Level  $V_{OL}$	5.0	—	0.05	—	0	0.05	—	0.05	Vdc
		10	—	0.05	—	0	0.05	—	0.05	
		15	—	0.05	—	0	0.05	—	0.05	
	"1" Level  $V_{OH}$	5.0	4.95	—	4.95	5.0	—	4.95	—	Vdc
		10	9.95	—	9.95	10	—	9.95	—	
		15	14.95	—	14.95	15	—	14.95	—	
Input Voltage "0" Level ( $V_O = 4.5$ or $0.5$ Vdc) ( $V_O = 9.0$ or $1.0$ Vdc) ( $V_O = 13.5$ or $1.5$ Vdc)  "1" Level ( $V_O = 0.5$ or $4.5$ Vdc) ( $V_O = 1.0$ or $9.0$ Vdc) ( $V_O = 1.5$ or $13.5$ Vdc)	$V_{IL}$	5.0	—	1.5	—	2.25	1.5	—	1.5	Vdc
		10	—	3.0	—	4.50	3.0	—	3.0	
		15	—	4.0	—	6.75	4.0	—	4.0	
	$V_{IH}$	5.0	3.5	—	3.5	2.75	—	3.5	—	Vdc
		10	7.0	—	7.0	5.50	—	7.0	—	
		15	11	—	11	8.25	—	11	—	
Output Drive Current ( $V_{OH} = 2.5$ Vdc) ( $V_{OH} = 4.6$ Vdc) ( $V_{OH} = 9.5$ Vdc) ( $V_{OH} = 13.5$ Vdc)  ( $V_{OL} = 0.4$ Vdc) ( $V_{OL} = 0.5$ Vdc) ( $V_{OL} = 1.5$ Vdc)	Source  $I_{OH}$	5.0	-3.0	—	-2.4	-4.2	—	-1.7	—	mAdc
		5.0	-0.64	—	-0.51	-0.88	—	-0.36	—	
		10	-1.6	—	-1.3	-2.25	—	-0.9	—	
		15	-4.2	—	-3.4	-8.8	—	-2.4	—	
	Sink  $I_{OL}$	5.0	0.64	—	0.51	0.88	—	0.36	—	mAdc
		10	1.6	—	1.3	2.25	—	0.9	—	
15		4.2	—	3.4	8.8	—	2.4	—		
Input Current	$I_{in}$	15	—	$\pm 0.1$	—	$\pm 0.00001$	$\pm 0.1$	—	$\pm 1.0$	$\mu$ Adc
Input Capacitance ( $V_{in} = 0$ )	$C_{in}$	—	—	—	—	5.0	7.5	—	—	pF
Quiescent Current (Per Package)	$I_{DD}$	5.0	—	5.0	—	0.005	5.0	—	150	$\mu$ Adc
		10	—	10	—	0.010	10	—	300	
		15	—	20	—	0.015	20	—	600	
Total Supply Current**† (Dynamic plus Quiescent, Per Package) ( $C_L = 50$ pF on all outputs all buffers switching)	$I_T$	5.0	$I_T = (1.0 \mu\text{A/kHz}) f + I_{DD}$							$\mu$ Adc
		10	$I_T = (2.0 \mu\text{A/kHz}) f + I_{DD}$							
		15	$I_T = (3.0 \mu\text{A/kHz}) f + I_{DD}$							

#Data labelled "Typ" is not to be used for design purposes but is intended as an indication of the IC's potential performance.

\*\*The formulas given are for the typical characteristics only at 25°C.

†To calculate total supply current at loads other than 50 pF:

$$I_T(C_L) = I_T(50 \text{ pF}) + (C_L - 50) Vfk$$

where:  $I_T$  is in  $\mu\text{A}$  (per package),  $C_L$  in pF,  $V = (V_{DD} - V_{SS})$  in volts,  $f$  in kHz is input frequency, and  $k = 0.001$ .

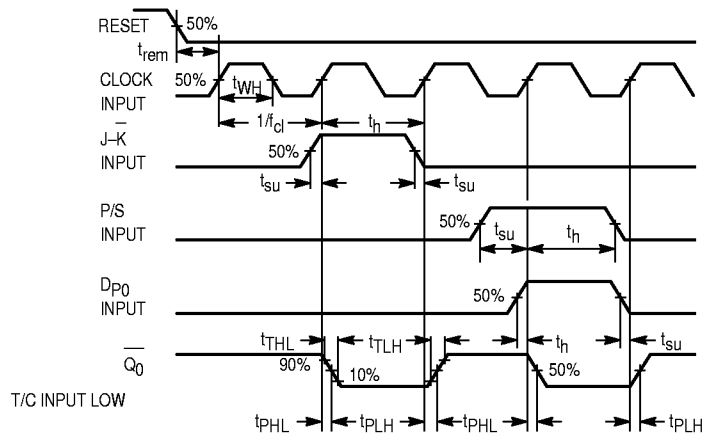
**This device contains protection circuitry to guard against damage due to high static voltages or electric fields. However, precautions must be taken to avoid applications of any voltage higher than maximum rated voltages to this high-impedance circuit. For proper operation,  $V_{in}$  and  $V_{out}$  should be constrained to the range  $V_{SS} \leq (V_{in} \text{ or } V_{out}) \leq V_{DD}$ . Unused inputs must always be tied to an appropriate logic voltage level (e.g., either  $V_{SS}$  or  $V_{DD}$ ). Unused outputs must be left open.**

**SWITCHING CHARACTERISTICS** ( $C_L = 50 \text{ pF}$ ,  $T_A = 25^\circ\text{C}$ , See Figure 1)

Characteristic	Symbol	V <sub>DD</sub> V <sub>dc</sub>	Min	Typ #	Max	Unit
Output Rise and Fall Time $T_{TLH}, T_{THL} = (1.5 \text{ ns/pF}) C_L + 25 \text{ ns}$ $T_{TLH}, T_{THL} = (0.75 \text{ ns/pF}) C_L + 12.5 \text{ ns}$ $T_{TLH}, T_{THL} = (0.55 \text{ ns/pF}) C_L + 12.5 \text{ ns}$	$t_{TLH},$ $t_{THL}$	5.0 10 15	— — —	100 50 40	200 100 80	ns
Propagation Delay Time, Clock or Reset to Q $T_{PLH}, T_{PHL} = (1.75 \text{ ns/pF}) C_L + 223 \text{ ns}$ $T_{PLH}, T_{PHL} = (0.70 \text{ ns/pF}) C_L + 89 \text{ ns}$ $T_{PLH}, T_{PHL} = (0.53 \text{ ns/pF}) C_L + 67 \text{ ns}$	$t_{PLH},$ $t_{PHL}$	5.0 10 15	— — —	300 130 95	600 260 190	ns
Clock Pulse Width	$t_{WH}$	5.0 10 15	335 165 125	135 45 40	— — —	ns
Reset Pulse Width	$t_{WH}$	5.0 10 15	400 175 130	80 40 35	— — —	ns
Reset Removal Time	$t_{rem}$	5.0 10 15	80 30 25	40 15 10	— — —	ns
Clock Pulse Rise and Fall Time	$t_{TLH}, t_{THL}$	5.0 10 15	No Limit			—
Clock Pulse Frequency	$f_{cl}$	5.0 10 15	— — —	2.5 6.0 10	1.2 2.0 3.0	MHz
J–K to Clock Setup Time	$t_{su}$	5.0 10 15	500 200 150	120 50 30	— — —	ns
Clock to J–K Hold Time	$t_h$	5.0 10 15	40 30 25	–40 –5 0	— — —	ns
P/S to Clock Setup Time	$t_{su}$	5.0 10 15	500 200 150	25 10 7.5	— — —	ns
Clock to P/S Hold Time	$t_h$	5.0 10 15	30 20 20	–70 –20 –10	— — —	ns
Dp to Clock Setup Time	$t_{su}$	5.0 10 15	500 200 150	90 20 15	— — —	ns
Clock to Dp Hold Time	$t_h$	5.0 10 15	90 40 40	–25 0 5	— — —	ns

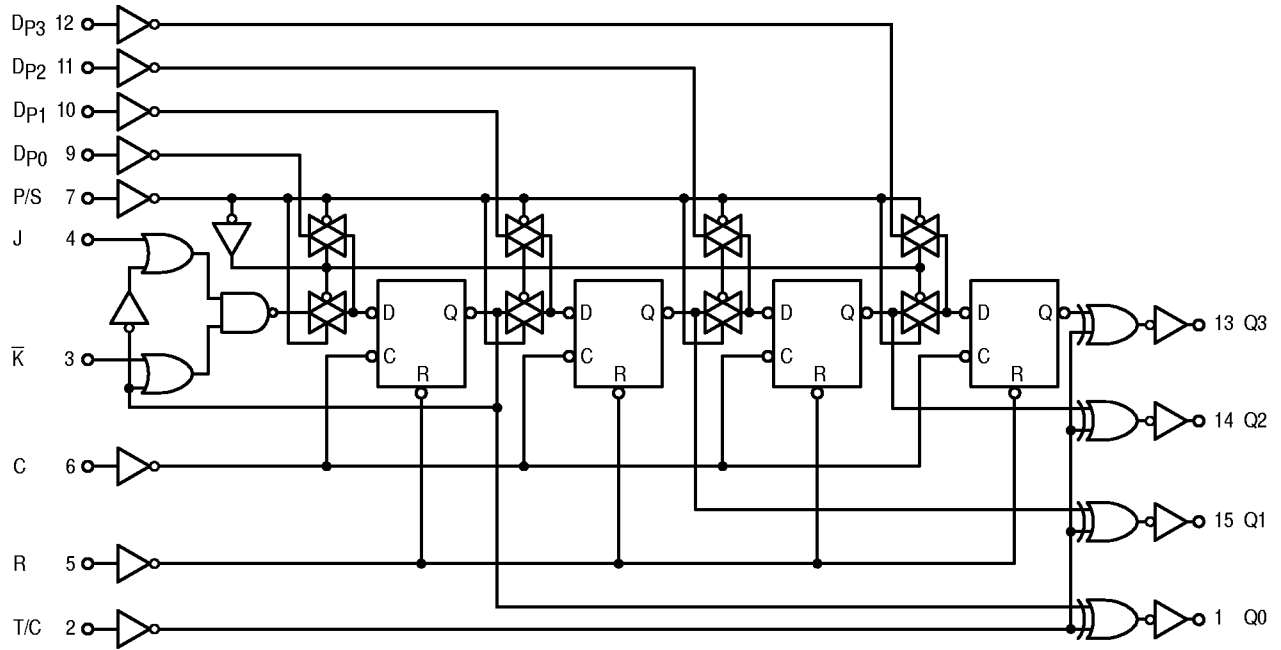
\* The formulas given are for the typical characteristics only at 25°C.

#Data labelled "Typ" is not to be used for design purposes but is intended as an indication of the IC's potential performance.

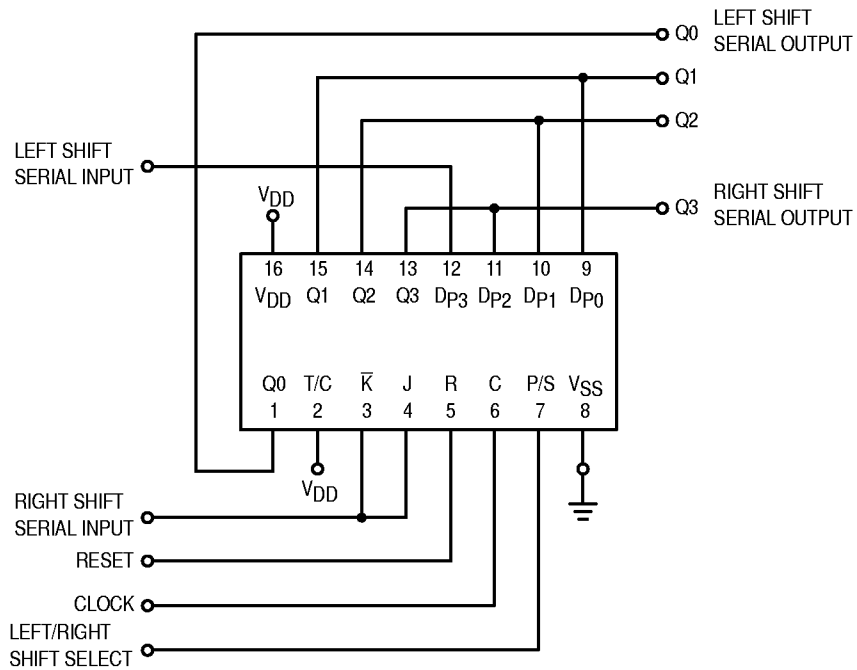


**Figure 1. Timing Diagram**

### LOGIC DIAGRAM

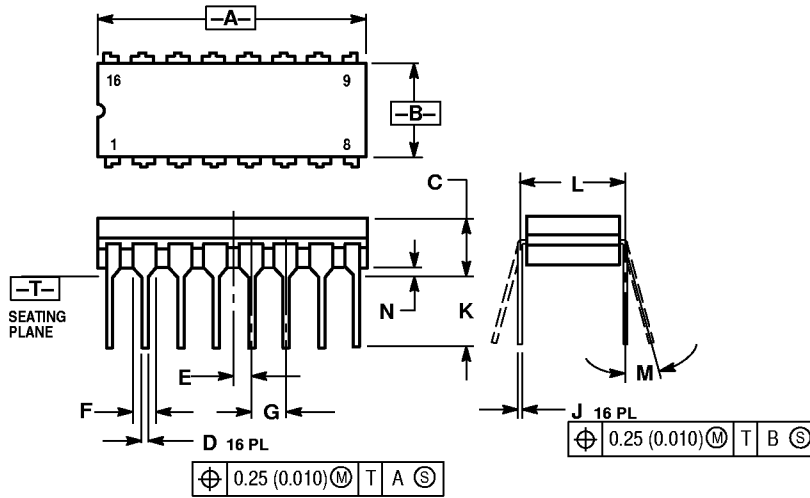


### APPLICATION DIAGRAM Shift Left/Shift Right Register



## OUTLINE DIMENSIONS

### L SUFFIX CERAMIC DIP PACKAGE CASE 620-10 ISSUE V

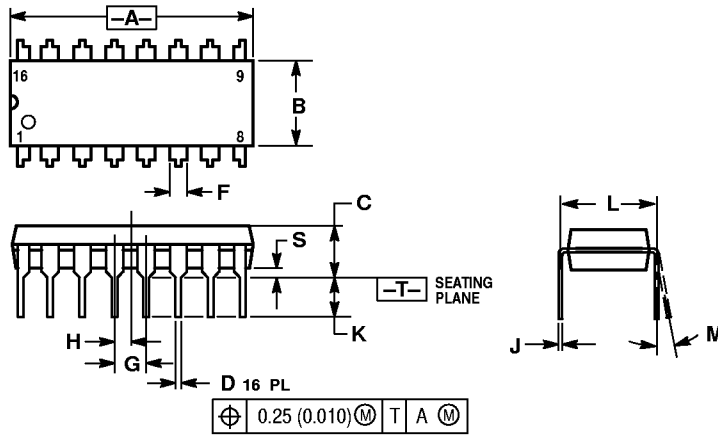


**NOTES:**

1. DIMENSIONING AND TOLERANCING PER ANSI Y14.5M, 1982.
2. CONTROLLING DIMENSION: INCH.
3. DIMENSION L TO CENTER OF LEAD WHEN FORMED PARALLEL.
4. DIMENSION F MAY NARROW TO 0.76 (0.030) WHERE THE LEAD ENTERS THE CERAMIC BODY.

DIM	INCHES		MILLIMETERS	
	MIN	MAX	MIN	MAX
A	0.750	0.785	19.05	19.93
B	0.240	0.295	6.10	7.49
C	—	0.200	—	5.08
D	0.015	0.020	0.39	0.50
E	0.050 BSC		1.27 BSC	
F	0.055	0.065	1.40	1.65
G	0.100 BSC		2.54 BSC	
H	0.008	0.015	0.21	0.38
K	0.125	0.170	3.18	4.31
L	0.300 BSC		7.62 BSC	
M	0°	15°	0°	15°
N	0.020	0.040	0.51	1.01

### P SUFFIX PLASTIC DIP PACKAGE CASE 648-08 ISSUE R



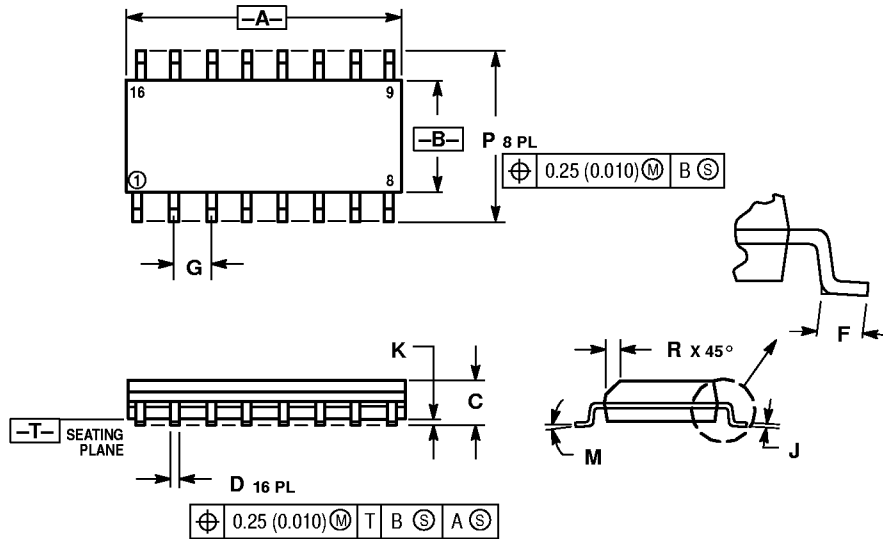
**NOTES:**

1. DIMENSIONING AND TOLERANCING PER ANSI Y14.5M, 1982.
2. CONTROLLING DIMENSION: INCH.
3. DIMENSION L TO CENTER OF LEADS WHEN FORMED PARALLEL.
4. DIMENSION B DOES NOT INCLUDE MOLD FLASH.
5. ROUNDED CORNERS OPTIONAL.

DIM	INCHES		MILLIMETERS	
	MIN	MAX	MIN	MAX
A	0.740	0.770	18.80	19.55
B	0.250	0.270	6.35	6.85
C	0.145	0.175	3.69	4.44
D	0.015	0.021	0.39	0.53
F	0.040	0.70	1.02	1.77
G	0.100 BSC		2.54 BSC	
H	0.050 BSC		1.27 BSC	
J	0.008	0.015	0.21	0.38
K	0.110	0.130	2.80	3.30
L	0.295	0.305	7.50	7.74
M	0°	10°	0°	10°
S	0.020	0.040	0.51	1.01

## OUTLINE DIMENSIONS

### D SUFFIX PLASTIC SOIC PACKAGE CASE 751B-05 ISSUE J



**NOTES:**

1. DIMENSIONING AND TOLERANCING PER ANSI Y14.5M, 1982.
2. CONTROLLING DIMENSION: MILLIMETER.
3. DIMENSIONS A AND B DO NOT INCLUDE MOLD PROTRUSION.
4. MAXIMUM MOLD PROTRUSION 0.15 (0.006) PER SIDE.
5. DIMENSION D DOES NOT INCLUDE DAMBAR PROTRUSION. ALLOWABLE DAMBAR PROTRUSION SHALL BE 0.127 (0.005) TOTAL IN EXCESS OF THE D DIMENSION AT MAXIMUM MATERIAL CONDITION.

DIM	MILLIMETERS		INCHES	
	MIN	MAX	MIN	MAX
A	9.80	10.00	0.386	0.393
B	3.80	4.00	0.150	0.157
C	1.35	1.75	0.054	0.068
D	0.35	0.49	0.014	0.019
F	0.40	1.25	0.016	0.049
G	1.27	BSC	0.050	BSC
J	0.19	0.25	0.008	0.009
K	0.10	0.25	0.004	0.009
M	0°	7°	0°	7°
P	5.80	6.20	0.229	0.244
R	0.25	0.50	0.010	0.019

Motorola reserves the right to make changes without further notice to any products herein. Motorola makes no warranty, representation or guarantee regarding the suitability of its products for any particular purpose, nor does Motorola assume any liability arising out of the application or use of any product or circuit, and specifically disclaims any and all liability, including without limitation consequential or incidental damages. "Typical" parameters which may be provided in Motorola data sheets and/or specifications can and do vary in different applications and actual performance may vary over time. All operating parameters, including "Typicals" must be validated for each customer application by customer's technical experts. Motorola does not convey any license under its patent rights nor the rights of others. Motorola products are not designed, intended, or authorized for use as components in systems intended for surgical implant into the body, or other applications intended to support or sustain life, or for any other application in which the failure of the Motorola product could create a situation where personal injury or death may occur. Should Buyer purchase or use Motorola products for any such unintended or unauthorized application, Buyer shall indemnify and hold Motorola and its officers, employees, subsidiaries, affiliates, and distributors harmless against all claims, costs, damages, and expenses, and reasonable attorney fees arising out of, directly or indirectly, any claim of personal injury or death associated with such unintended or unauthorized use, even if such claim alleges that Motorola was negligent regarding the design or manufacture of the part. Motorola and are registered trademarks of Motorola, Inc. Motorola, Inc. is an Equal Opportunity/Affirmative Action Employer.

**How to reach us:**

**USA/EUROPE/Locations Not Listed:** Motorola Literature Distribution;  
P.O. Box 20912; Phoenix, Arizona 85036. 1-800-441-2447 or 602-303-5454

**JAPAN:** Nippon Motorola Ltd.; Tatsumi-SPD-JLDC, 6F Seibu-Butsuryu-Center,  
3-14-2 Tatsumi Koto-Ku, Tokyo 135, Japan. 03-81-3521-8315

**MFAX:** RMFAX0@email.sps.mot.com – TOUCHTONE 602-244-6609  
**INTERNET:** http://Design-NET.com

**ASIA/PACIFIC:** Motorola Semiconductors H.K. Ltd.; 8B Tai Ping Industrial Park,  
51 Ting Kok Road, Tai Po, N.T., Hong Kong. 852-26629298



MC14035B/D

