

alle Kontakte/all contacts  
 $\phi$  0.13 (M)

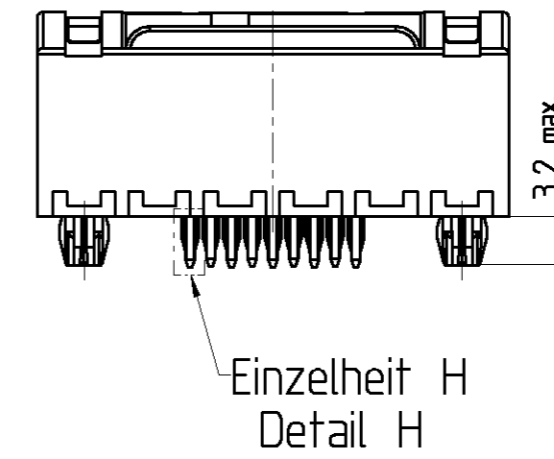

Einzelheit H (20:1)  
Detail H (20:1)

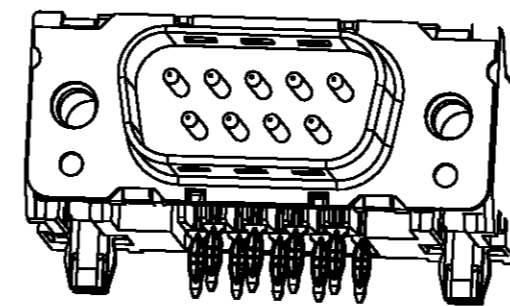
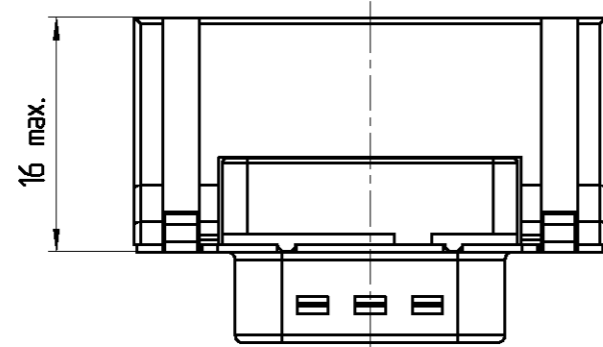
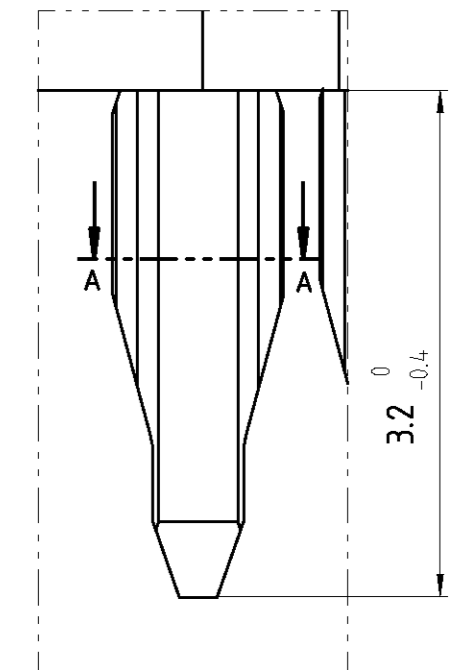

Schnitt AA (20:1)  
Section (20:1)

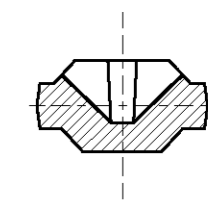

- 4) Plated-through hole ; incl. plating  
suitable for compliant press-in zone  
PCB-plating-through : 5...15  $\mu$ m Sn or SnPb over min. 25  $\mu$ m Cu  
Drilled holes :  $\phi$ 1.15  $\pm$ 0.025 and  $\phi$ 3.15  $\pm$ 0.025
  - 3) torquereferentation  $\geq$  70 Ncm
  - 2) according to DIN 41611 p.5, DIN IEC 353-5; incl. plating
  - 1) according to DIN 41652 p.2 and p.4
- 
- 4) Durchmetallisierte Löcher; incl. Oberflächenbehandlung  
Geeignet für elastische Einpreßzonen  
Metallierung des Loches: 5...15  $\mu$ m Sn oder SnPb über min. 25  $\mu$ m Cu  
Bohrdurchmesser:  $\phi$ 1.15  $\pm$ 0.025 und  $\phi$ 3.15  $\pm$ 0.025
  - 3) Verdrehsicherheit  $\geq$  70 Nm
  - 2) Nach DIN 41611 T.5, DIN IEC 352-5; incl. Oberflächenbehandlung
  - 1) Nach DIN 41652 T.2 und T.4

Sachnr./Ordercode V23529-R1****-	Polzahl n Contacts n	Maß/Dimension				
		A	B	C	D	L
C*09	09	31.19	16.79	25.00 $\begin{smallmatrix} +0.12 \\ -0.13 \end{smallmatrix}$	2.74	6.12
C*15	15	39.52	25.12	33.30 $\begin{smallmatrix} +0.15 \\ -0.1 \end{smallmatrix}$	2.74	6.12
C*25	25	53.42	38.84	47.04 $\begin{smallmatrix} +0.13 \\ -0.13 \end{smallmatrix}$	2.76	5.99
C*37	37	69.70	55.50	63.50 $\begin{smallmatrix} +0.13 \\ -0.13 \end{smallmatrix}$	2.76	5.99

Anforderungsstufe 1)  
performance level 1)

Sachnr./Ordercode V23529-	Maß/Dimension $\phi$ G
R1*02-C***	M3
R1*03-C***	4-40UNC

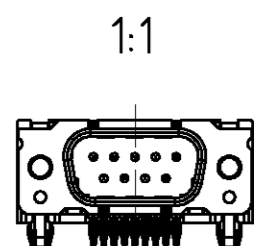

Dargestellt wird die 9-polige Ausführung V23529-R1202-C209  
On the drawing : the 9 pole version V23529-R1202-C209

CHANGES TO THIS DRAWING MUST BE DONE ONLY IN CAD		PAPER SIZE A2
APPLICABLE SPEC. :	FINISH	
	DIMENSIONS APPLY	PLATING
SCALE 2:1, 20:1, 1:1		WEIGHT
MATERIAL		
DATE 7.2.96	NAME Sub-D 90° abgewinkelt Standard Einpreß	
NAME Sterckx	Stiftleiste	
APP. EC CS CI	D-Sub 90° angled standard press fit	
	Pin	
C ECO-17-002586 10OCT2017 D.G.	TOLERANCE UNLESS SPECIFIED OTHERWISE	NO. V23529-R****-C****-7427
B ECO-15-007873 24-06-15 SB		SHT. 1
A4 ECO-11-005294 14APR11 HMR		OF 3
REV. CHANGE ORDER	DATE	APP.
CUSTOMER DRAWING No.: C 2-1393481-5		

Ausführung mit Gewindebolzen  
Version with studbolt  
V23529-R1\*04/R1\*05-C\*\*\*

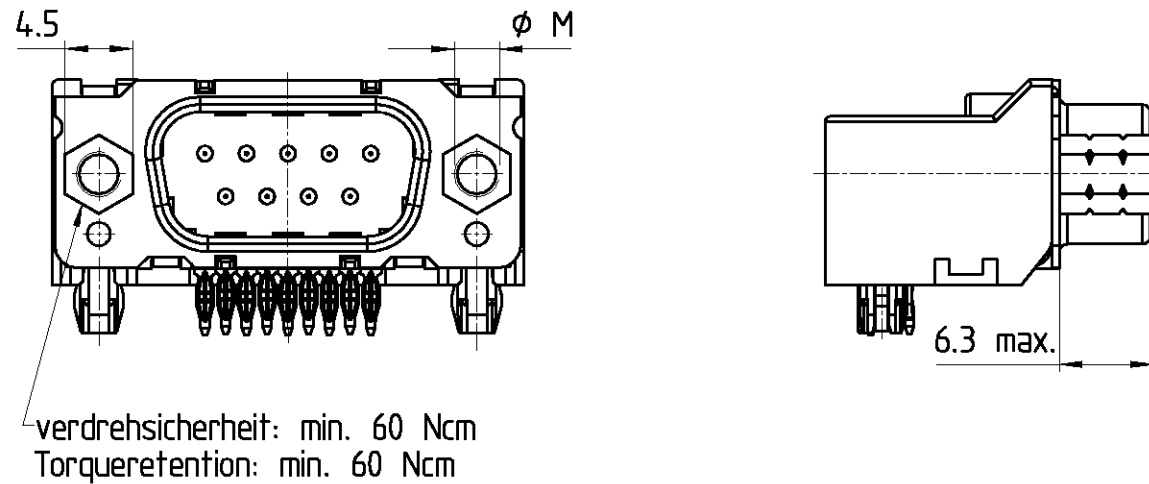

Sachnr./Ordercode V23529-	Maß/Dimension Ø M
R1*04-C***	M3
R1*05-C***	4-40UNC

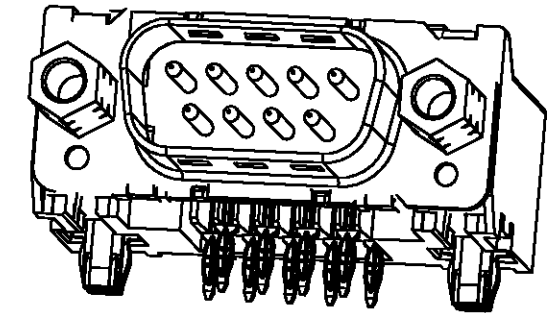

Leiterplattenbohrung (2:1)  
PCB hole pattern (2:1)

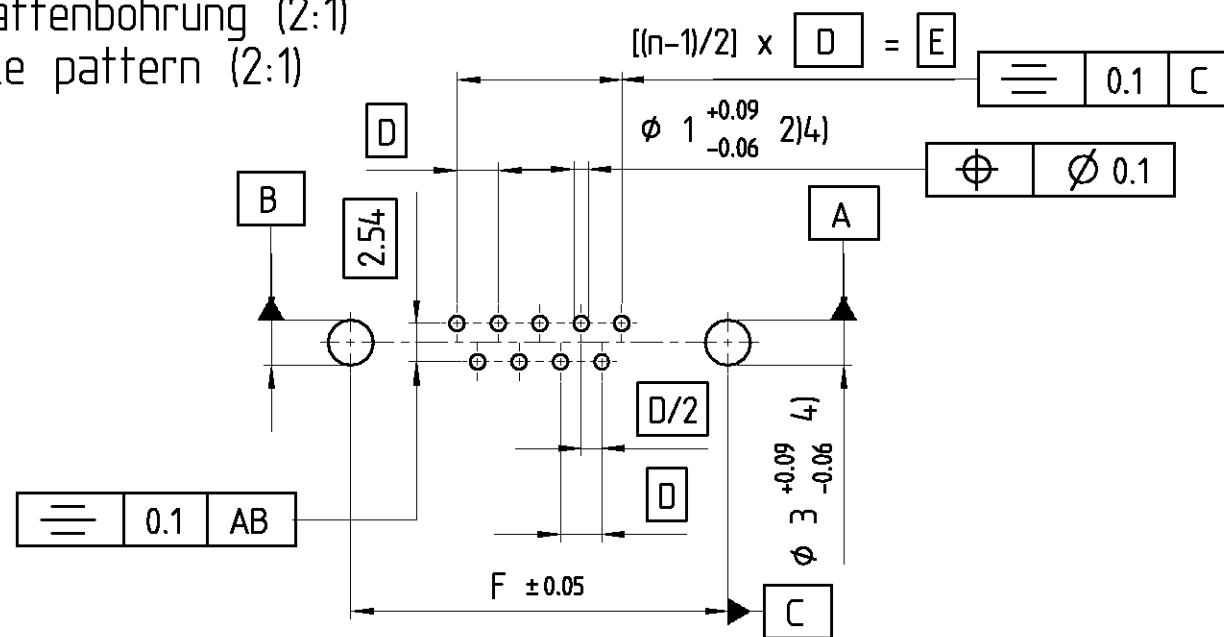

Sachnr./Ordercode V23529-R1***-	Polzahl n Contacts n	Maß/Dimension		
		D	E	F
C*09	09	2.74	10.96	25.00
C*15	15	2.74	19.18	33.30
C*25	25	2.76	33.12	47.04
C*37	37	2.76	49.68	63.50

Anforderungsstufe 1)  
performance level 1)

Verpreßhinweis  
press-in information

Einpressen über Kunststoff mit:  
- 2-Hub-Pressen 60kN : 1-1393491-3  
- Einpreßmaschine 60/100 kN : 4-1393488-2  
Zu verwendenden Werkzeuge :  
- Drückstück : 1393490-6  
- Amboß : 3-1393489-5  
Einstellhöhe : Abstand zwischen LP und  
angedrucktem Stempel : 11.15 bis 11.3mm

pressing in via the plastic body :  
- 2-stroke press 60kN : 1-1393491-3  
- press-fit machine 60/100kN : 4-1393488-2  
pressing-in tools :  
-Compression tool : 1393490-6  
-anvil : 3-1393489-5  
set-up heights : distance between PCB and  
compression tool : 11.15 to 11.3 mm

Erläuterungen siehe Seite 1  
Remarks see page 1

APPLICABLE SPEC.:		FINISH	
DIMENSIONS APPLY		PLATING	
SCALE 2:1		WEIGHT	
MATERIAL		NAME	
		Sub-D 90° abgewinkelt Standard Einpreß Stiftleiste D-Sub 90° angled standard press fit Pin	
DATE 7.2.96		NO.	
NAME Sterckx		V23529-R****-C***-7427	
DEP. EC CS CI		SHT. 2	
C see page 1		TOLERANCE UNLESS SPECIFIED OTHERWISE	
B see page 1		CUSTOMER DRAWING No.: C 2-1393481-5	
A4 see page 1		OF 3	
REV.	CHANGE ORDER	DATE	APP.

PROPRIETARY

Sub-D 90° abgewinkelt Einpreß // D-Sub 90° press-in

V 2 3 5 2 9 - + \* \* \* \* - + \* \* \*

EINBAUHÖHE // MOUNTING HEIGHT

R = Standardbauhöhe 7.3mm // Standard Style 7.3 mm

AUFBAU // CONFIGURATION

1 = isoliert // insulated  
2 = geschirmt 1) // shielded 1)

BESCHRIFTUNG // MARKING

1 = tyco // tyco  
2 = Neutral // neutral  
3 = Sonderbeschriftung A // special marking A  
4 = Sonderbeschriftung B // special marking B  
5 = Sonderbeschriftung C // special marking C

ANSCHLUßAUSFÜHRUNG // CONTACT TYPE

0, 1 = EP-Stiel 3.2 mm // press-in pin 3.2 mm long

BEFESTIGUNG Steckseite/Leiterplatteseite // MOUNTING CONNECTOR/PCB

01 = Loch Ø3 / ohne Massekontakt 1) // hole Ø3 / without grounding  
02 = Gewinde M3 / mit Massekontakt // thread M3 / with grounding  
03 = Gewinde 4-40 UNC / mit Massekontakt // thread 4-40 UNC / with grounding  
04 = Gewindebolzen M3 / mit Massekontakt // studbolt srewlock M3 / with grounding  
05 = Gewindebolzen 4-40 UNC / mit Massekontakt // studbolt srewlock 4-40 UNC / with grounding

1) in Vorbereitung // in preparation

STECKERPOLZAHL // NO OF CONTACTS

09 = 9-polig // 9-contact  
15 = 15-polig // 15-contact  
25 = 25-polig // 25-contact  
37 = 37-polig // 37-contacto rea

ANFORDERUNGSSTUFE // PERFORMANCE LEVEL

2 = Anf. II // PL II

STECKERART // CONNECTOR TYPE

C = Stiftleiste mit Schirmfiederung // male connector with grounding fingers

Active part numbers. Contact TE CONNECTIVITY for other configuration availability

Old Part Number	TE CONNECTIVITY Part Number
V23529-R1102-C209	2-1393481-5
V23529-R1102-C215	2-1393481-6
V23529-R1102-C225	2-1393481-7
V23529-R1102-C237	2-1393481-8
V23529-R1103-C209	3-1393481-2
V23529-R1103-C215	3-1393481-3
V23529-R1103-C225	3-1393481-4
V23529-R1103-C237	2-1392010-7 - OBSOLETE
V23529-R1105-C209	3-1393481-8 - OBSOLETE
V23529-R1105-C215	3-1393481-9 - OBSOLETE
V23529-R1105-C225	2-1393497-7 - OBSOLETE
V23529-R1105-C237	4-1393481-0 - OBSOLETE

CHANGES TO THIS DRAWING MUST BE DONE ONLY IN CAD		PAPER SIZE A2
APPLICABLE SPEC.:		FINISH
DIMENSIONS APPLY		PLATING
SCALE		WEIGHT
MATERIAL		
 TE Connectivity		
DATE	7.2.96	NAME
NAME	Sterckx	APP.
APP.	CI PD	
TOLERANCE UNLESS SPECIFIED OTHERWISE		NO.
C see page 1		Sub-D 90° abgewinkelt Standard Einpreß
B see page 1		Stiftleiste
A4 see page 1		D-Sub 90° angled standard press fit
		Pin
REV. CHANGE ORDER		DATE
APP.		CUSTOMER DRAWING No.: C 2-1393481-5
		SHT. 3
		OF 3