

Product Information

Thermopile Infrared Sensor

MLX90247

The MLX90247 Thermopile Infrared Sensor uses a thermopile to sense the temperature difference between object and detector, and a thermistor for measurement of the detector's own temperature. Calculation of the absolute object temperature is possible through the combination of both outputs. The MLX90247 is supplied uncalibrated.

Features and Benefits

- Contact-less temperature measurement based on infrared emission by the object.
- High reliability fully CMOS-compatible process.
- Thermistor integrated in the thermopile sensor chip for optimal tracking of sensor temperature.
- Nitrogen-filled hermetic TO-39 package.
- Coated silicon window for >75% infrared transmission in the wavelength interval 5.5 μm to 14.5 μm .
- The silicon window blocks visible light and short-wavelength infrared light emitted by infrared communication devices.
- Automotive qualified.
- ESD sensitivity: up 8 kV

Applications

- Automotive climate control and windshield anti-fog sensing
- Residential / Industrial climate control
- Medical and bio-instrumentation
- Industrial process control
- Consumer applications: microwave oven, hair dryer
- Detection of occupancy or movement
- High speed temperature change detection

Melexis
Microelectronic Integrated Systems



Automotive ICs

RF & RFID

Intelligent Drivers
and Actuators

IR Temperature

Hall ICs

CMOS Imaging

Silicon MEMS

BUS ICs



Small things make a big difference.

Block Diagram

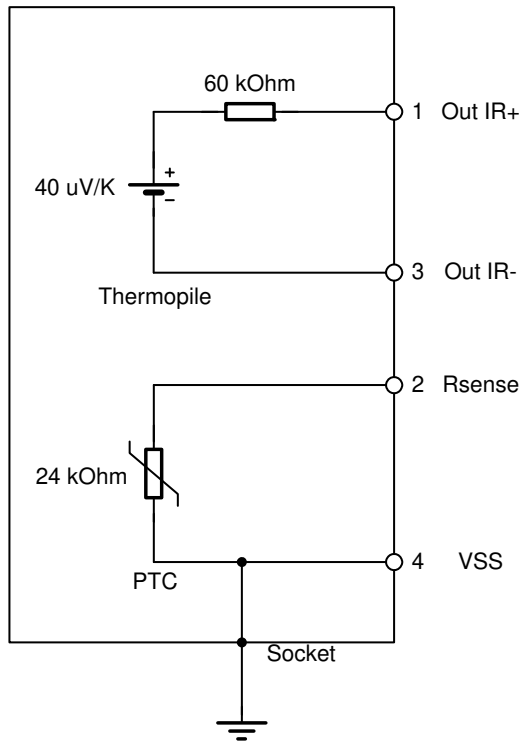

TO-39 package - connections

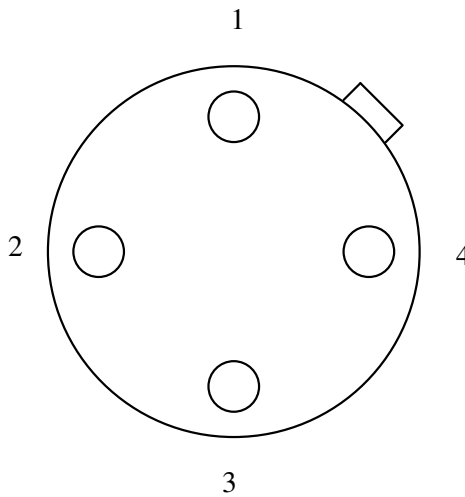

Top view = pins down

Disclaimer:

Devices sold by Melexis are covered by the warranty and patent indemnification provisions appearing in its Term of Sale. Melexis makes no warranty, express, statutory, implied, or by description regarding the information set forth herein or regarding the freedom of the described devices from patent infringement. Melexis reserves the right to change specifications and prices at any time and without notice. Therefore, prior to designing this product into a system, it is necessary to check with Melexis for current information. This product is intended for use in normal commercial applications. Applications requiring extended temperature range, unusual environmental requirements, or high reliability applications, such as military, medical life-support or life-sustaining equipment are specifically not recommended without additional processing by Melexis for each application. The information furnished by Melexis is believed to be correct and accurate. However, Melexis shall not be liable to recipient or any third party for any damages, including but not limited to personal injury, property damage, loss of profits, loss of use, interrupt of business or indirect, special incidental or consequential damages, of any kind, in connection with or arising out of the furnishing, performance or use of the technical data herein. No obligation or liability to recipient or any third party shall arise or flow out of Melexis' rendering of technical or other services. © 2006 Melexis NV. All rights reserved.

Email Europe and rest of the world:
sales_europe@melexis.com

Email USA :
sales_usa@melexis.com

Email Asia:
sales_asia@melexis.com

For additional information go to our website at:

