



**KVX1905 - KVX1975 / KVX1401 / KVX1501**  
 SURFACE MOUNT VARACTOR DIODES  
 SOT-23 SUPER-HYPERABRUPT JUNCTION  
 RoHS Compliant

**GENERAL DESCRIPTION**

Designed for the demands of today's commercial surface mount products, these devices offer the high quality and reliability of our military microwave devices in a cost effective SOT-23 plastic package. Capacitance values are available for VCO's from VHF thru 1.5 GHz. High  $C_T$  ratios provide excellent bandwidth and straight line mid-range sensitivities in a low voltage varactor. Our proprietary grown junction epitaxy provides the highest Q values in the industry.

This series of diodes meets RoHS requirements per EU Directive 2002/95/EC.

**KEY FEATURES**

- Silicon Mesa Geometry
- High Reliability Dense SiO<sub>2</sub> Passivation
- Lower Parasitics
- Widest Tuning Ratios
- Highest Q Available
- Mil Spec Performance/Economy Price
- Tape & Reel Available for Pick & Place Assembly
- RoHS Compliant <sup>1</sup>

**APPLICATIONS**

These devices are the ideal choice for wireless fixed, mobile, or portable applications. Devices are available in package style 23-0 (single die) or 23-4 (common cathode, 2 die). Some limitations apply. Consult factory for availability.

**APPLICATION/BENEFITS**

- Low Voltage Wireless Open Loop VCO's
- Low Voltage Wireless PLL VCO's
- TCXO's, VCXO's, VVF's
- Phase Shifter

<sup>1</sup> These devices are supplied with a matte tin finish suitable for RoHS compliant assembly.

**ABSOLUTE MAXIMUM RATINGS @ 25°C**

Rating	Symbol	Value	Unit
Power Dissipation (De-rated linearly to 0 at T <sub>J</sub> (max))	P <sub>D</sub>	250	mW
Leakage Current @ 10 V	I <sub>R</sub>	50	nA
Storage Temperature	T <sub>STG</sub>	-55 to +125	°C
Operating Temperature	T <sub>OP</sub>	-55 to +125	°C

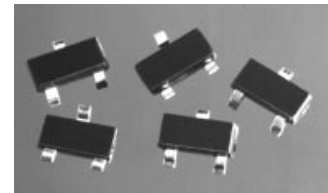

For the most current data, consult MICROSEMI's website: [www.MICROSEMI.com](http://www.MICROSEMI.com)  
 Specifications are subject to change, consult the RFIS factory at (978) 442-5600 for the latest information.



**KVX1905 - KVX1975 / KVX1401 / KVX1501**  
 SURFACE MOUNT VARACTOR DIODES  
 SOT-23 SUPER-HYPERABRUPT JUNCTION  
 RoHS Compliant

**DEVICE ELECTRICAL PARAMETERS AT 25°C**

**(4V & 8V) UHF SUPER HYPERABRUPT VARACTORS**

Model Number	V <sub>B</sub> (V) I <sub>R</sub> =10μA (Min)	C <sub>T</sub> (pF) @1V (Min)	C <sub>T</sub> (pF) @2.5V	C <sub>T</sub> (pF) @4V (Max)	C <sub>T</sub> (pF) @8V (Max)	Q @4V, 50 MHz (Min)
KVX1975	12	9.0	4.5 – 6.5	3.0	--	400
KVX1932A	12	13	6.5 – 10.0	--	2.7	750
KVX1922A	12	17	8.5 – 13.0	--	3.2	600
KVX1952A	12	26	13.0 – 20.0	--	4.7	500
KVX1912A	12	36	18.0 – 27.0	--	6.2	400

**(6V) UHF SUPER HYPERABRUPT VARACTORS**

Model Number	V <sub>B</sub> (V) I <sub>R</sub> =10μA (Min)	C <sub>T</sub> (pF) @1V	Ratio C <sub>T1</sub> / C <sub>T3</sub>	Ratio C <sub>T1</sub> / C <sub>T6</sub>	Q @4V, 50 MHz (Min)
KVX1965A	12	3.0 – 3.6	1.4 – 1.9	2.6 – 3.3	1500
KVX1945A	12	5.85 – 7.15	1.6 – 2.0	2.8 – 3.4	1200
KVX1935A	12	10.35 – 12.65	1.6 – 2.0	2.9 – 3.4	1000
KVX1925A	12	15.5 – 18.5	1.6 – 2.0	3.0 – 3.5	900
KVX1905A	12	45 - 54	1.6 – 2.0	3.0 – 3.5	750

**(10V) UHF SUPER HYPERABRUPT VARACTORS**

Model Number	V <sub>B</sub> (V) I <sub>R</sub> =10μA (Min)	C <sub>T</sub> (pF) @2V (Min - Max)	C <sub>T</sub> (pF) @7V (Typ)	C <sub>T</sub> (pF) @10V (Min - Max)	Q @2V, 10 MHz (Min)
KVX1401	12	46 – 68	6.1	4.2 – 5.2	75
KVX1501	12	100 – 150	13.0	8.6 – 10.6	50

For the most current data, consult MICROSEMI's website: [www.MICROSEMI.com](http://www.MICROSEMI.com)  
 Specifications are subject to change, consult the RFIS factory at (978) 442-5600 for the latest information.



**KVX1905 - KVX1975 / KVX1401 / KVX1501**  
 SURFACE MOUNT VARACTOR DIODES  
 SOT-23 SUPER-HYPERABRUPT JUNCTION  
 RoHS Compliant

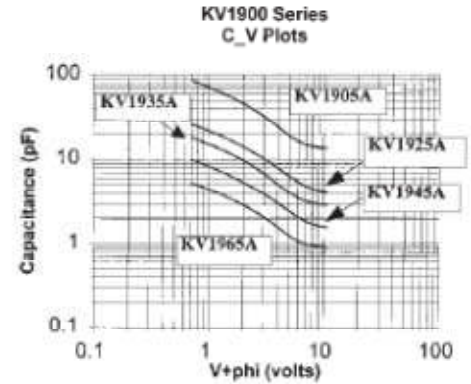
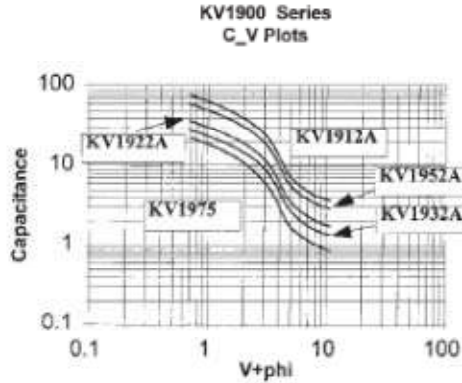
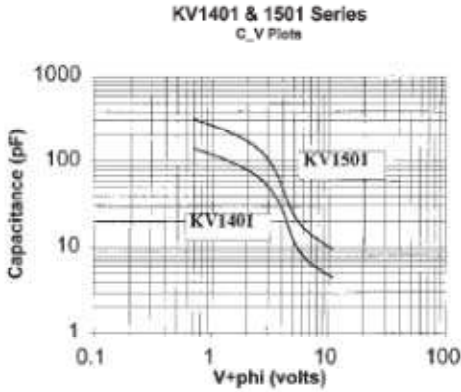

**PACKAGE STYLE 23**

**CONFIGURATIONS**

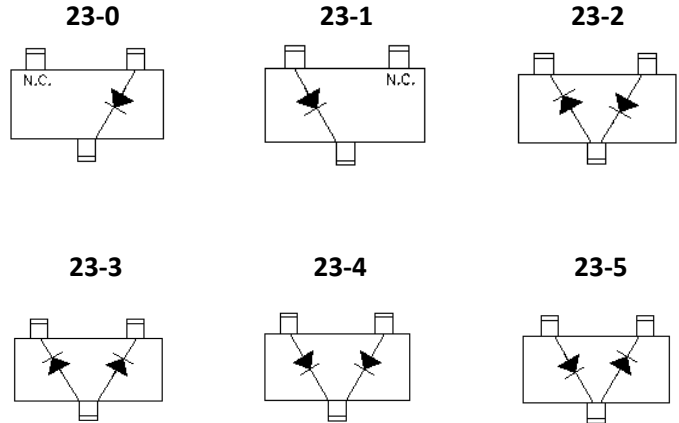
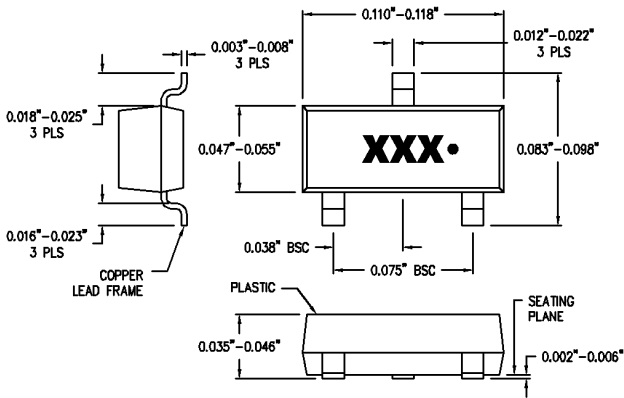

**Revision History**

Revision Level / Date	Para. Affected	Description
2009-02-02	-	Initial Release
1 / 12 November 2013	-	Reformat

For the most current data, consult MICROSEMI's website: [www.MICROSEMI.com](http://www.MICROSEMI.com)  
 Specifications are subject to change, consult the RFIS factory at (978) 442-5600 for the latest information.