



DATASHEET

SM200 Module

Copyright 2008-2018 Synapse Wireless, All Rights Reserved. All Synapse products are patent pending.
Synapse , the Synapse logo, SNAP, and Portal are all registered trademarks of Synapse Wireless, Inc.

Doc# 116-041507-001-H000

6723 Odyssey Drive // Huntsville, AL 35806 // (877) 982-7888 // synapsewireless.com

CONTENTS

1	Modules Overview	1
2	Specifications	3
3	Module Pin Definitions	5
4	Electrical Characteristics	9
5	Mechanical Drawings	11
6	Antenna Gain Performance	15
7	Board Mounting Considerations	19
8	Packaging	23
9	Agency Certifications	25

MODULES OVERVIEW

The SNAP Engine Model SM200 series includes the SM200P81 and SM200PU1 part numbers. They are IEEE 802.15.4, low-power, highly reliable solutions to embedded wireless control and monitoring network needs that require high data rates. The Model SM200 embeds Synapse's SNAP OS, the industry's first Internet-enabled, wireless mesh network operating system into the Atmel ATmega128RFA1 single-chip AVR® micro-controller with an integrated transceiver that delivers up to 2Mbps/sec. These low-cost modules can have current consumption as low as 0.37 μ A to enable a new generation of battery-driven systems.

SNAP's on-board Python interpreter provides for rapid application development and over-the-air programming, while Atmel's low-power RF single-chip design saves board space and lowers the overall Bill of Materials and power consumption. The Model SM200 modules are approved as an FCC Part 15 unlicensed modular transmitters, as well as having CE Certification and IC Certification. The modules provide up to 16 channels of operation in the ISM 2.4GHz frequency band.

By default, the SNAP operating system automatically forms a mesh network with other nodes immediately on receiving power. No further configuration is necessary. Multiple unrelated SNAP networks can exist within the same area through several configuration options outlined in the SNAP User Guide.

Datasheet covers Part Numbers SM200P81 and SM200PU1:

- 34 GPIO with up to 7 A/D inputs
- 128k flash, 58.5k free for over-the-air uploaded user apps
- Two UART ports for control or transparent data
- **Low power modes:**
 - 0.37 μ A with external interrupt
 - 1.37 μ A with internal timer running
- Spread Spectrum (DSSS) technology
- Up to 2 Mbps radio data rate
- 2.4 GHz RF Frequency
- AES 128-bit encryption
- Integrated chip antenna or U.FL connector
- Surface Mount, Solder-able
- 4K internal EEPROM
- 8 PWM outputs

The SM200 is also available with a U.FL connector. Contact Synapse for details.

Note: If your 200 series device shipped from the factory with version 2.4.34 of the SNAP firmware, it now supports over-the-air firmware upgrades. This process is further defined in the Portal User Guide.

SPECIFICATIONS

Table 2.1: SM200 Specifications at 25° C and 3.3V unless otherwise noted

Performance	Outdoor LOS Range	Up to 1500/2500 feet at 250Kbps
	Transmit Power Output	3 dBm
	RF Data Rate	250Kbps, 500Kbps, 1Mbps, 2Mbps
	Receiver Sensitivity	-100 dBm (1% PER, 250Kbps)
Power Requirements	Supply Voltage	2.0 - 3.6 V
	Transmit Current (Typ@3.3V)	22.5 mA
	Idle/Receive Current (Typ@3.3V)	20.5 mA
	Power-down Current (Typ@3.3V)	0.37 μ A
General	Frequency	ISM 2.4 GHz
	Spreading Method	Direct Sequence (DSSS)
	Modulation	O-QPSK
	Dimensions	29.8mm x 19mm
	Operating Temperature	-40 to 85 deg C.
	Antenna Options	Integrated Chip Antenna / External Antenna
Networking	Topology	SNAP
	Error Handling	Retries and acknowledgement
	Number of Channels	16
Available I/O	UARTS with HW Flow Control	2 Ports
	GPIO	34 total; 7 can be analog-in with 10bit ADC

Continued on next page

Table 1 – continued from previous page

Agency Approvals	FCC Part 15.247	FCC ID: U90-SM200
	Industry Canada (IC)	IC: 7084A-SM200
	CE Certified	Certified to EN300 328 Version 2.1.1

You must preserve access to UART1 as a serial connection in order to be able to update firmware on the node, or to recover the node by forced script removal or parameter reset.

MODULE PIN DEFINITIONS

For pin locations, consult the SM200 Mechanical drawing later in this document.

Table 3.1: SM200PF1/PU1 Pin Assignments

SM200 Pin	SNAPpy IO	Pin Name	Pin Description
A1		GND	Power Supply
A2		VCC	Power Supply
A3		VCC	Power Supply
A4	24	PF0_ADC0	IO or Analog0
A5	26	PF2_ADC2_DIG2	IO or Analog2 or SPI CLK
A6	28	PF4_ADC4_TCK	IO or Analog4 or JTAG Test Clock
A7	30	PF6_ADC6_TDO	IO or Analog6 or JTAG Test Data Out or I2C SDA
A8		GND	Power Supply
B1	18	PE2_XCK0_AIN0	IO or software SPI1 MISO or Analog Comparator or External Clock
B2	19	PE3_OC3A_AIN1	IO or Analog Comparator or PWM or Output Compare Match
B3	21	PE5_OC3C_INT5	IO or UART0 RTS Input or PWM or Interrupt
B4	25	PF1_ADC1	IO or Analog1 or software SPI MOSI
B5	33	PG1_DIG1	IO
B6	29	PF5_ADC5_TMS	IO or Analog5 or JTAG Test Mode Select
B7	31	PF7_ADC7_TDI	IO or Analog7 or JTAG Test Data In or software

Continued on next page

Table 1 – continued from previous page

SM200 Pin	SNAPpy IO	Pin Name	Pin Description
B8		GND	Power Supply
C1	16	PE0_RXD0_PCINT8	IO or UART0 Data In or Interrupt
C2	17	PE1_TXD0	IO or UART0 Data Out
C3	20	PE4_OC3B_INT4	IO or UART0 CTS Output or PWM or Interrupt
C4	22	PE6_T3_INT6	IO or Interrupt
C5	23	PE7_ICP3_INT7_CLK 0	IO or UART1 RTS input or Clock Output Buffer or Interrupt
C6	27	PF3_ADC3_DIG4	IO or ADC channel 3
C7		NC	
C8		GND	Power Supply
D1	5	PB5_OC1A_PCINT5	IO or PWM or Interrupt
D2	6	PB6_OC1B_PCINT6	IO or PWM or Interrupt
D3	7	PB7_OC0A_OC1C_PCINT7	IO or PWM or Interrupt
D4		NC	
D5		NC	
D6		NC	
D7		NC	
D8		GND	Power Supply
E1	2	PB2_MOSI_PCINT2 ¹	IO or Interrupt
E2	3	PB3_MISO_PCINT3 ¹	IO or Interrupt
E3	4	PB4_OC2A_PCINT4	IO or PWM or Interrupt
E4		NC	
E5		NC	
E6		NC	
E7		NC	

Continued on next page

Table 1 – continued from previous page

SM200 Pin	SNAPpy IO	Pin Name	Pin Description
E8		NC	
F1	0	PB0_SSN_PCINT0 ¹	IO or Interrupt
F2	1	PB1_SCK_PCINT1 ¹	IO or Interrupt
F3	9	PD1_SDA_INT1 ¹	IO or Interrupt
F4	8	PD0_SCL_INT0 ¹	IO or Interrupt
F5		NC	
F6		NC	
F7		NC	
F8		GND	Power Supply
G1		NC	
G2	15	PD7_T0	IO
G3	12	PD4_ICP1	IO or UART1 CTS output or Input Capture
G4	10	PD2_RXD1_INT2	IO or UART1 Data In or Interrupt
G5	37	PG5_OC0B	IO or PWM
G6		NC	
G7		NC	
G8		GND	Power Supply
H1		GND	Power Supply
H2	14	PD6_T1	IO or Timer/Counter1 clock input
H3	13	PD5_XCK1	IO
H4	11	PD3_TXD1_INT3	IO or UART1 Data Out or Interrupt
H5		RESET#	Module Reset, Active Low
H6		NC	
H7		NC	

Continued on next page

Table 1 – continued from previous page

SM200 Pin	SNAPpy IO	Pin Name	Pin Description
H8		GND	Power Supply

¹These pins have special I2C and/or SPI hardware that is not natively supported by SNAP. You could use peek and poke to initialize and enable this hardware functionality, but it is not supported by Synapse and we cannot guarantee your results.

Table 3.2: SM200/SNAPpy IO Cross Reference

Pad	SNAPpy IO
A4	24
A5	26
A6	28
A7	30
B1	18
B2	19
B3	21
B4	25
B5	33
B6	29
B7	31
C1	16
C2	17
C3	20
C4	22
C5	23
C6	27
D1	5
D2	6
D3	7
E1	2
E2	3
E3	4
F1	0
F2	1
F3	9
F4	8
G2	15
G3	12
G4	10
G5	37
H2	14
H3	13
H4	11

ELECTRICAL CHARACTERISTICS

Table 4.1: SM200 DC Characteristics at 25° C

Symbol	Parameter	Condition	Min	Typ	Max	Units
V_{CC}^1	Supply Voltage		2.0	3.3	3.6	V
T_{OP}	Operating Temp		-40		85	°C
T_{STOR}	Storage Temp		-40		125	°C
V_{IH}	Input Hi Voltage	All Digital Inputs	0.7 V_{CC}			V
V_{IL}	Input Low Voltage	All Digital Inputs			0.3 V_{CC}	V
V_{OL}	Output Low Voltage	All drive strengths (2,4,6,8 mA)			0.4	V
V_{OH}	Output High Voltage	All drive strengths (2,4,6,8 mA)	$V_{CC}-$ 0.4			V
I_{LIN}	In Leakage Current	$V_{IN} = V_{CC}$ or V_{SS} , all Pins		<10nA	1	μA
$TX-I_{CC}$	Transmit Current - Transceiver only	$V_{CC} = 3.3V$ $P_{TX} = 3dBm$		14.5		mA
	Transmit Current - Transceiver and CPU			22.5		mA
$RX-I_{CC}$	Receive Current - Transceiver only	$V_{CC} = 3.3V$		12.5		mA
	Receive Current - Transceiver and CPU			20.5		mA
$SHDN-I_{CC}$		$V_{CC} = 3.3V$		0.37		μA

¹Absolute maximum stress rated voltage for V_{CC} is -0.3 to 3.6. It is recommended that bulk capacitance be located as close as possible to the V_{CC} pin on the host board. Ideally, use a single 47μF capacitor at 10V directly at the V_{CC} pin.

Table 4.2: ADC Electrical Characteristics (Operating)

V_{REFH}^1	ADC Voltage Reference, High	Programmable	1.5	1.6	1.8	V
V_{INDC}	Analog input voltage	Single Ended	0		1.8	V
		Differential ²	0		3.3	V

Table 4.3: ADC Timing/Performance Characteristics

Symbol	Parameter	Condition	Min	Typical	Max	Unit
R _{AS}	Source impedance at input ¹				3k	kΩ
RES	Conversion Resolution	Single Ended CLKADC ≤ 4MHz		10		Bits
DNL	Differential non- linearity	V _{REFH} = 1.6V CLKADC=4MHz	-0.5			LSB
INL	Integral non- linearity	V _{REFH} = 1.6V CLKADC=4MHz		0.8		LSB
E _{ZS}	Zero-scale error			1.5		LSB
E _G	Gain error			1		LSB

¹Any analog source with a source impedance greater than 3kΩ will increase the sampling time.

Table 4.4: Reset, Brown-out and Internal Voltage Characteristics

Symbol	Parameter	Condition	Min	Typical	Max	Unit
V _{POT (rising)}	Power-on Reset Threshold Voltage (rising)	Power supply fully discharged		1.6		V
V _{POT (falling)}	Power-on Reset Threshold Voltage (falling)		0.05	0.3		V
t _{POT}	Power-on Reset recovery time	Time of EVDD/DEVDD < V _{POT}	1			ms
V _{PSR}	Power-on slope rate		1.8		3300	V/ms
V _{RST}	RSTN Pin Threshold Voltage		0.1V _{DD}		0.9 V _{DD}	V
t _{RST}	Minimum pulse width on RSTN Pin			200	300	ns
V _{HYS}	Brown-out Detector Hysteresis			7.5	50	mV
t _{BOD}	Min Pulse Width on Brown-out Reset			100		ns

MECHANICAL DRAWINGS

The drawings below show the modules with the option of the integrated chip antenna or U.FL Connector.

Note: The area under the module's antenna (marked NO COPPER or KEEP OUT AREA) should have no components, no traces, and no copper on any layer of the printed circuit board.

Note: Metric measurements in millimeters are between brackets, with standard measurements in inches below.

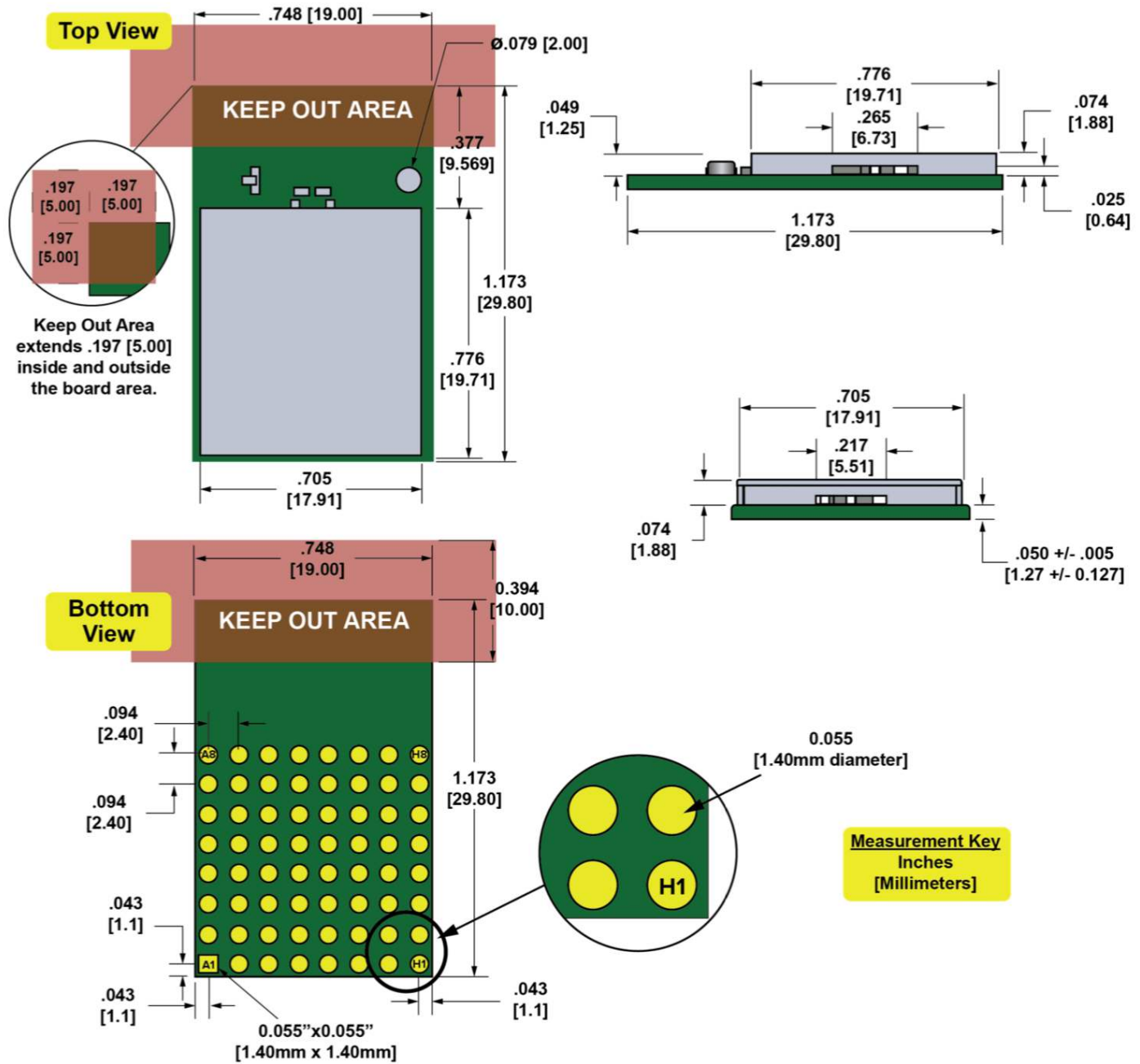

Fig. 1: SM200PF1/PU1 Mechanical Drawing

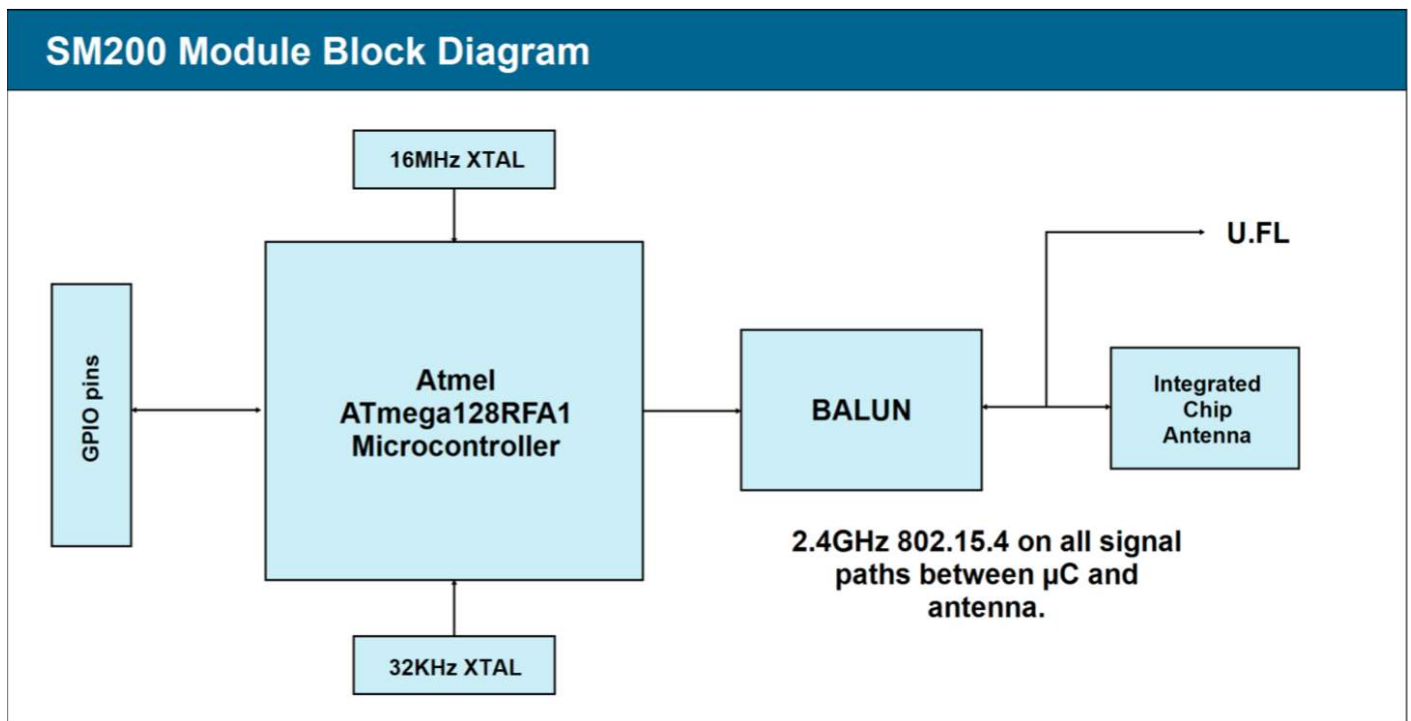

Fig. 2: Block diagram showing the major subsystems comprising Model SM200

ANTENNA GAIN PERFORMANCE

Note: Antenna gain performance information is based on information from the individual companies at the time this document's release. For added assurance, it's best to obtain antenna performance information directly from that antenna's manufacturer.

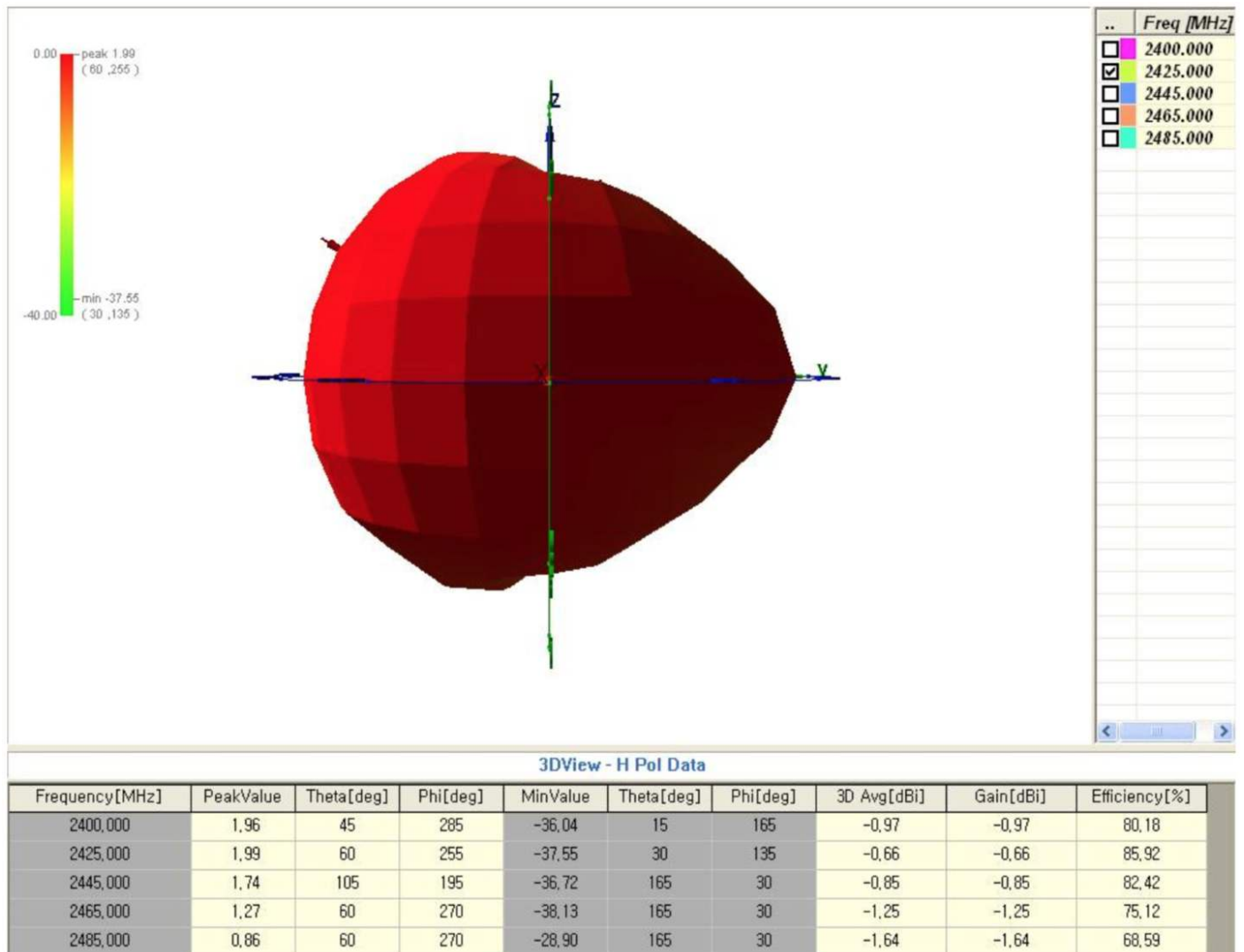
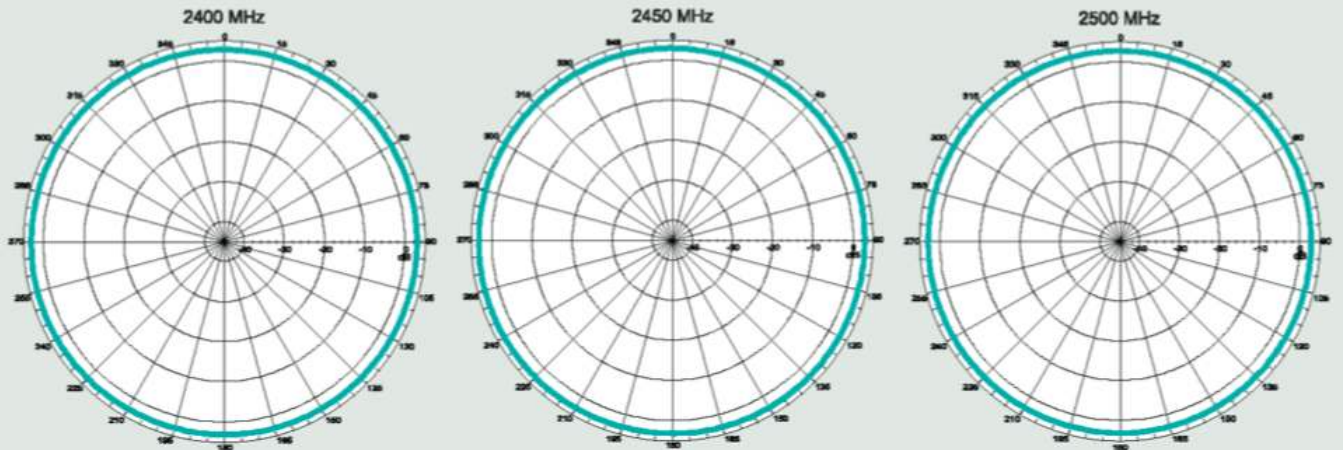

Fig. 1: Partron SDBTPTR3015 Antenna Gain Performance

Horizontal Position



Vertical Position

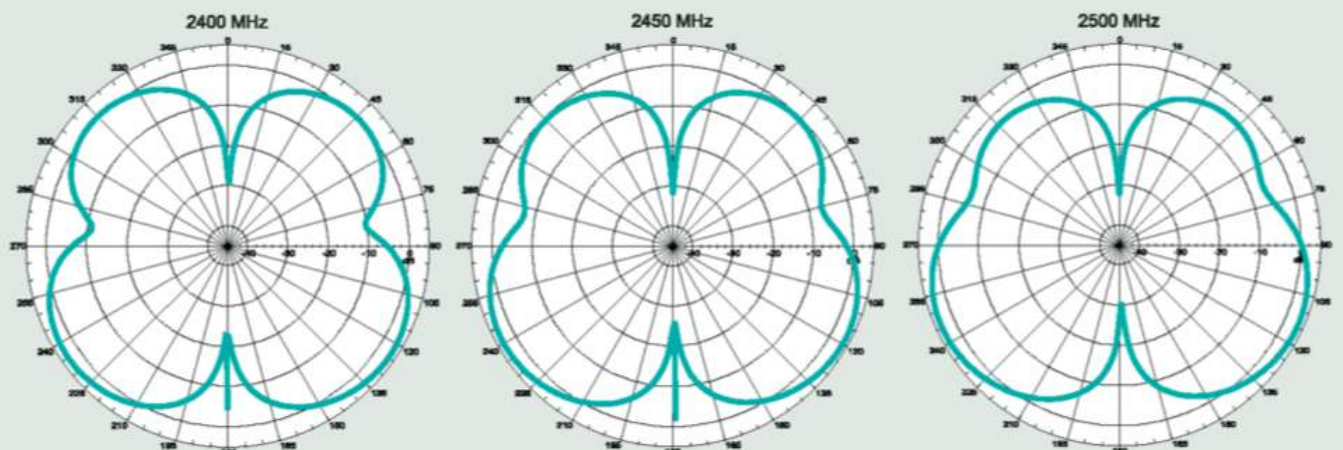
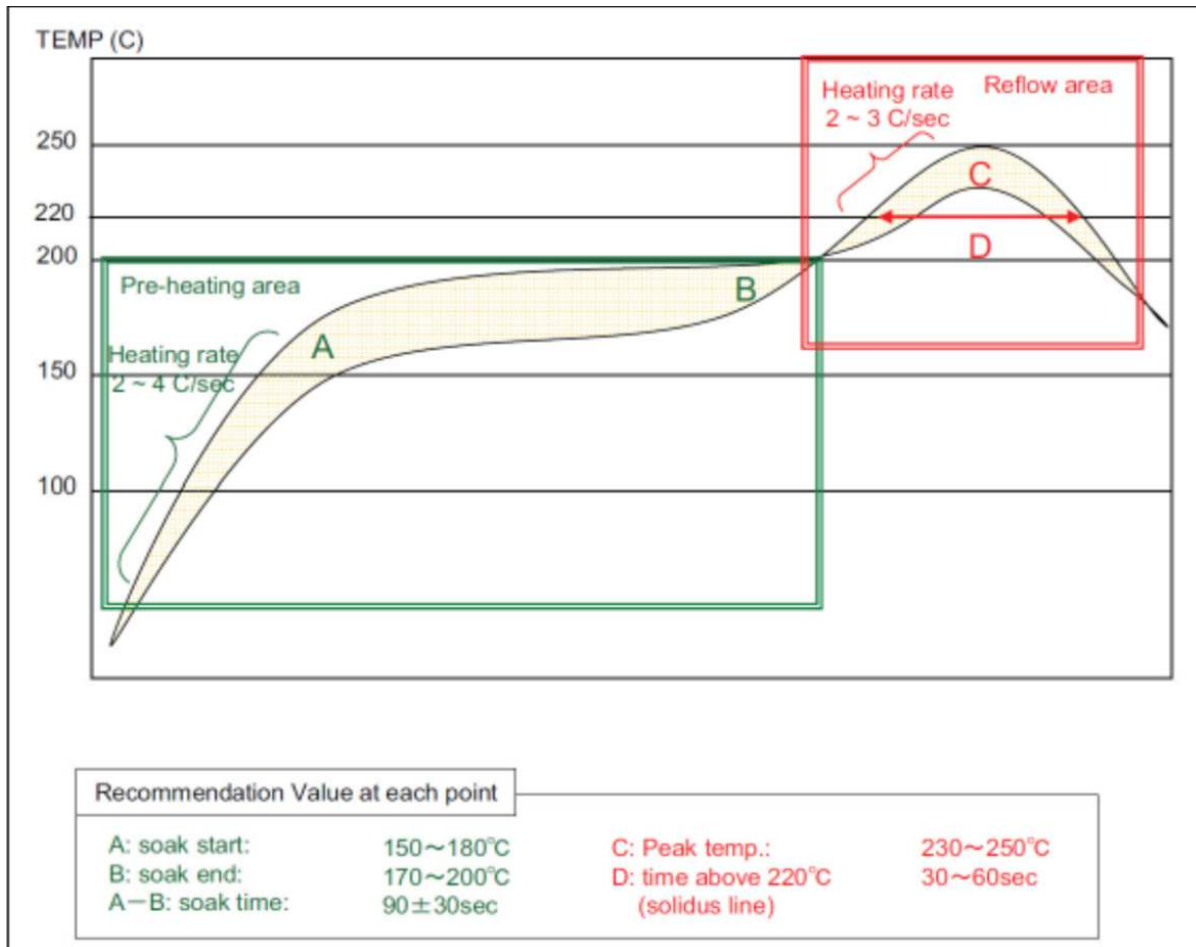

Fig. 2: Pulse W1027 Antenna Gain Performance

BOARD MOUNTING CONSIDERATIONS**7.1 Processing****Table 7.1: Recommended Reflow Profile**

Parameter	Value
Ramp up rate (from Tsoakmax to Tpeak)	3°/sec max
Minimum Soak Temperature	150°C
Maximum Soak Temperature	200°C
Soak Time	60-120 sec
TLiquidus	217°C
Time above TL	30-60 sec (recommended: 40 sec)
Tpeak	230° - 250°C (recommended: 235oC)
Time within 5° of Tpeak	20-30 sec
Time from 25° to Tpeak	8 min max
Ramp down rate	6°C/sec max



7.2 Pb-Free Soldering Paste

Use of “No Clean” soldering paste is strongly recommended, as it does not require cleaning after the soldering process.

7.3 Cleaning

In general, cleaning the populated modules is strongly discouraged. Residuals under the module cannot be easily removed with any cleaning process.

- Cleaning with water can lead to capillary effects where water is absorbed into the gap between the host board and the module. The combination of soldering flux residuals and encapsulated water could lead to short circuits between neighboring pads. Water could also damage any stickers or labels.
- Cleaning with alcohol or a similar organic solvent will likely flood soldering flux residuals into the two housings, which is not accessible for post-washing inspection. The solvent could also damage any stickers or labels.
- Ultrasonic cleaning could damage the module permanently.

The recommended approach is to consider using a “no clean” soldering paste and eliminate the post-soldering cleaning step.

7.4 Repeating Reflow Soldering

Only a single reflow soldering process is encouraged for host boards.

7.5 Rework

The Model SM200 Module can be unsoldered from the host board, but the process is likely to damage the chip and not recommended. If attempting this, use of a hot air rework tool and hot plate for pre-heating from underneath is recommended. Avoid overheating.

<p>Warning: Never attempt a rework on the module itself (e.g. replacing individual components). Such actions will terminate warranty coverage.</p>

7.6 Additional Grounding

Attempts to improve module or system grounding by soldering braids, wires, or cables onto the module RF shield cover is done at the customer's own risk. The numerous ground pins at the module perimeter should be sufficient for optimum immunity to external RF interference.

PACKAGING

Synapse SM series modules are available on plastic reels of carrier tape. The dimensions for those reels are provided below.

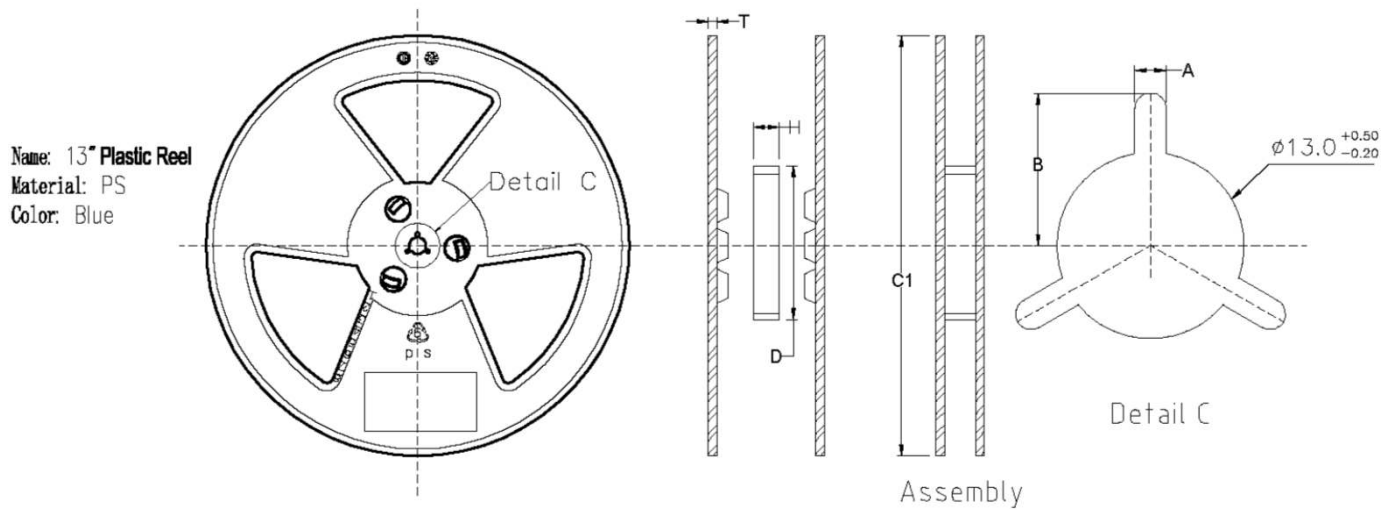

H \pm 0.5	C1 \pm 1.0	A \pm 0.2	C \pm 0.5-0.2	T \pm 0.3	B \pm 0.2	D \pm 2.0
44.5	$\phi 330$	2.2	13	2.2	10.75	99.5

All dimensions are in mm.

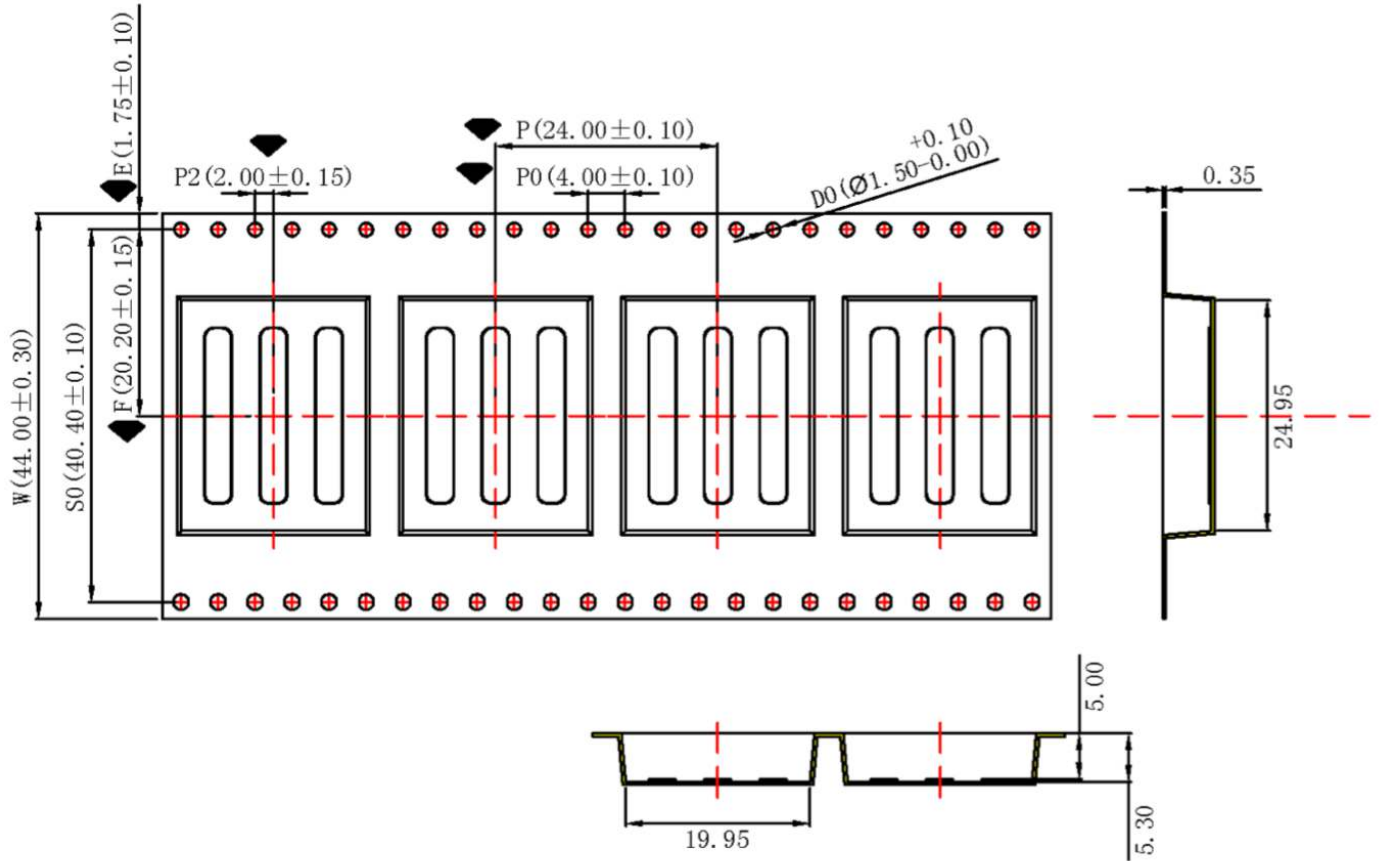

1. Sprocket hole pitch cumulative tolerance: +/-0.2mm.
2. Carrier camber not to exceed 1mm in 250mm.
3. All dimensions meet EIA-481-C requirements.
4. Thickness: 0.35mm +/- 0.05mm.
5. Packing length per reel: 12.6 meters.
6. Component load per reel: 500 pieces.

AGENCY CERTIFICATIONS

9.1 United States (FCC)

The Model SM200 modules comply with Part 15 of the FCC rules and regulations. Compliance with the labeling requirements, FCC notices, and antenna usage guidelines is required. In order to comply with FCC Certification requirements, the Original Equipment Manufacturer (OEM) must fulfill the following requirements.

1. The system integrator must place an exterior label on the outside of the final product housing the SM200 Modules. FCC Label below shows the contents that must be included on this label.
2. SM200 Modules may only be used with the antenna that has been tested and approved for use with the module. Please refer to the antenna table provided in this section.

9.2 OEM Labeling Requirements

NOTICE: The OEM must make sure that FCC labeling requirements are met. This includes a clearly visible exterior label on the outside of the final product housing that displays the contents shown in FCC Label below.

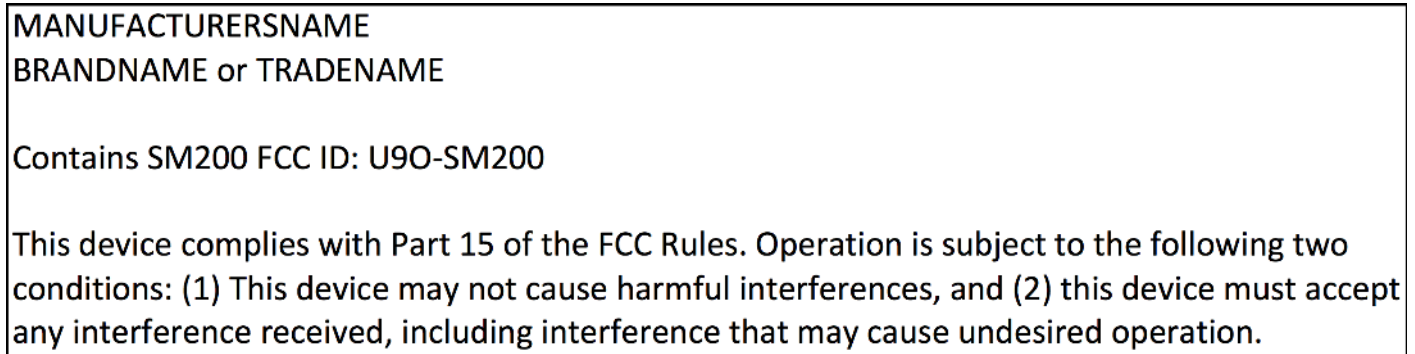

Fig. 1: FCC Label

9.3 FCC Notices

Warning: The SM200 modules have been tested by the FCC for use with other products without further certification (as per FCC Section 2.1091). Changes or modifications to this device not expressly approved by Synapse Wireless Inc. could void the user's authority to operate the equipment.

NOTICE: OEM's must certify final end product to comply with unintentional radiators (FCC Sections 15.107 and 15.109) before declaring compliance of their final product to Part 15 of the FCC Rules.

This equipment has been tested and found to comply with the limits for a Class B digital device, pursuant to Part 15 of the FCC Rules. These limits are designed to provide reasonable protection against harmful interference in a residential installation. This equipment generates, uses, and can radiate radio frequency energy, and if not installed and used in accordance with the instructions, may cause harmful interference to radio communications. However, there is no guarantee that interference will not occur in a particular installation.

If this equipment does cause harmful interference to radio or television reception, which can be determined by turning the equipment off and on, the user is encouraged to try to correct the interference by one or more of the following measures:

- Reorient or relocate the receiving antenna.
- Increase the separation between the equipment and receiver.
- Connect the equipment into an outlet on a circuit different from that to which the receiver is connected.
- Consult the dealer or an experienced radio/TV technician for help.

9.4 FCC Approved Antennas

The SM200 modules are FCC-approved for fixed base station, mobile, and portable applications.

NOTICE: To reduce potential radio interference to other users, the antenna type and its gain should be chosen so that the equivalent isotropically radiated power (EIRP) is not more than that permitted for successful communication. This module has been designed to operate with the antennas listed in SM200 Approved FCC Antennas above. The required antenna impedance is 50 ohms.

In order to comply with FCC/ISED RF Exposure requirements, this device must be installed to provide at least 20 cm separation from the human body at all times.

Table 8.1: SM200 Approved FCC Antennas

Part Number	Type	Gain	Application	Min. Separation
Partron SDBTPTR3015	Chip	1.96 dBi	Fixed/Mobile	20 cm.

Table 8.2: SM200 Approved FCC Antennas

Part Number	Type	Gain	Application	Min. Separation
Pulse W1027	Dipole (quarter-wave RPSMA)	3.2 dBi	Fixed/Mobile	20 cm.

For more information on approved antennas, please consult the manufacturer's website.

Note: Antenna and transmitters may be co-located or operated in conjunction with this device only if the transmitters do not simultaneously transmit. Otherwise, additional regulatory requirements will apply.

9.5 Canada (IC)

This device complies with Industry Canada license-exempt RSS standard(s). Operation is subject to the following two conditions: (1) this device may not cause interference, and (2) this device must accept any interference, including interference that may cause undesired operation of the device.

Le présent appareil est conforme aux CNR d'Industrie Canada applicables aux appareils radio exempts de licence. L'exploitation est autorisée aux deux conditions suivantes : (1) l'appareil ne doit pas produire de brouillage, et (2) l'utilisateur de l'appareil doit accepter tout brouillage radioélectrique subi, même si le brouillage est susceptible d'en compromettre le fonctionnement.

Under Industry Canada regulations, this radio transmitter may only operate using an antenna of a type and maximum (or lesser) gain approved for the transmitter by Industry Canada. To reduce potential radio interference to other users, the antenna type and its gain should be so chosen that the equivalent isotropically radiated power (EIRP) is not more than that necessary for successful communication.

Conformément à la réglementation d'Industrie Canada, le présent émetteur radio peut fonctionner avec une antenne d'un type et d'un gain maximal (ou inférieur) approuvé pour l'émetteur par Industrie Canada. Dans le but de réduire les risques de brouillage radioélectrique à l'intention des autres utilisateurs, il faut choisir le type d'antenne et son gain de sorte que la puissance isotrope rayonnée équivalente (p.i.r.e.) ne dépasse pas l'intensité nécessaire à l'établissement d'une communication satisfaisante.

This radio transmitter Model: SM200, IC: 7084A-SM200 has been approved by Industry Canada to operate with the antenna types listed below with the maximum permissible gain and required antenna impedance for each antenna type indicated. Antenna types not included in this list, having a gain greater than the maximum gain indicated for that type, are strictly prohibited for use with this device.

Le présent émetteur radio Model : SM200, IC : 7084A-SM200 a été approuvé par Industrie Canada pour fonctionner avec les types d'antenne énumérés ci-dessous et ayant un gain admissible maximal et l'impédance requise pour chaque type d'antenne. Les types d'antenne non inclus dans cette liste, ou dont le gain est supérieur au gain maximal indiqué, sont strictement interdits pour l'exploitation de l'émetteur.

In order to comply with FCC/ISED RF Exposure requirements, this device must be installed to provide at least 20 cm separation from the human body at all times.

Afin de se conformer aux exigences d'exposition RF FCC / ISED, cet appareil doit être installé pour fournir au moins 20 cm de séparation du corps humain en tout temps.

Table 8.3: SM200 Approved IC Antennas

Part Number	Type	Gain	Application	Min. Separation
Partron SDBTPTR3015	Chip	1.96 dBi	Fixed/Mobile	20 cm.

Table 8.4: SM200 Approved IC Antennas

Part Number	Type	Gain	Application	Min. Separation
Pulse W1027	Dipole (quarter-wave RPSMA)	3.2 dBi	Fixed/Mobile	20 cm.

9.6 CE Approved Antennas

The SM200 modules are CE-approved for fixed base station and mobile applications.

NOTICE: To reduce potential radio interference to other users, the antenna type and its gain should be chosen so that the equivalent isotropically radiated power (EIRP) is not more than that permitted for successful communication. This module has been designed to operate with the antennas listed in SM200 Approved FCC Antennas above. The required antenna impedance is 50 ohms.

In order to comply with FCC/ISED RF Exposure requirements, this device must be installed to provide at least 20 cm separation from the human body at all times.

Table 8.5: SM200 Approved CE Antennas

Part Number	Type	Gain	Application	Min. Separation
Partron SDBTPTR3015	Chip	1.96 dBi	Fixed/Mobile	20 cm.

Table 8.6: SM200 Approved CE Antennas

Part Number	Type	Gain	Application	Min. Separation
Pulse W1027	Dipole (quarter-wave RPSMA)	3.2 dBi	Fixed/Mobile	20 cm.

For more information on approved antennas, please consult the manufacturer's website.

Note: Antenna and transmitters may be co-located or operated in conjunction with this device only if the transmitters do not simultaneously transmit. Otherwise, additional regulatory requirements will apply.

9.7 IC OEM Labeling Requirements

Labeling requirements for Industry Canada are similar to those of the FCC. A clearly visible label on the outside of the final product housing must display the contents shown in IC Label below.

MANUFACTURERSNAME BRANDNAME or TRADENAME MODEL: Contains SM200 IC: 7084A-SM200

Fig. 2: IC Label

Note: The OEM can choose to implement a single label combined for both FCC and IC labeling requirements. If a combined single label is chosen, there must be a clearly visible label on the outside of the final product housing displaying the contents shown in Combined FCC and IC Label below.

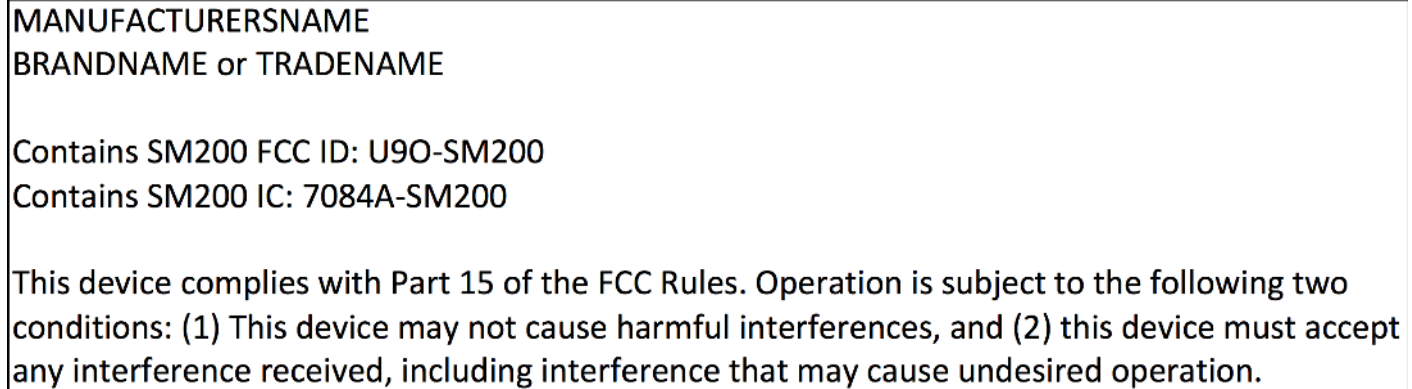

Fig. 3: Combined FCC and IC Label

9.8 OEM Labeling Requirements for the European Union



The “CE” mark must be placed on the OEM product in a visible location. The CE mark will consist of the Initials “CE” with the following form:

If the CE marking is reduced or enlarged, the proportions given in the following drawing must be adhered to.

The CE mark must be a minimum of 5mm in height.

The CE marking must be affixed visibly, legibly, and indelibly.

Since the 2400-2483.5 MHz band is not harmonized by a few countries throughout Europe, the Restriction sign must be placed to the right of the CE marking as shown in the drawing.

Note: The OEM can choose to implement a single label combined for FCC, CE and IC labeling requirements. If a combined single label is chosen, there must be a clearly visible label on the outside of the final product housing displaying the contents shown in Combined FCC, CE and IC Label above.

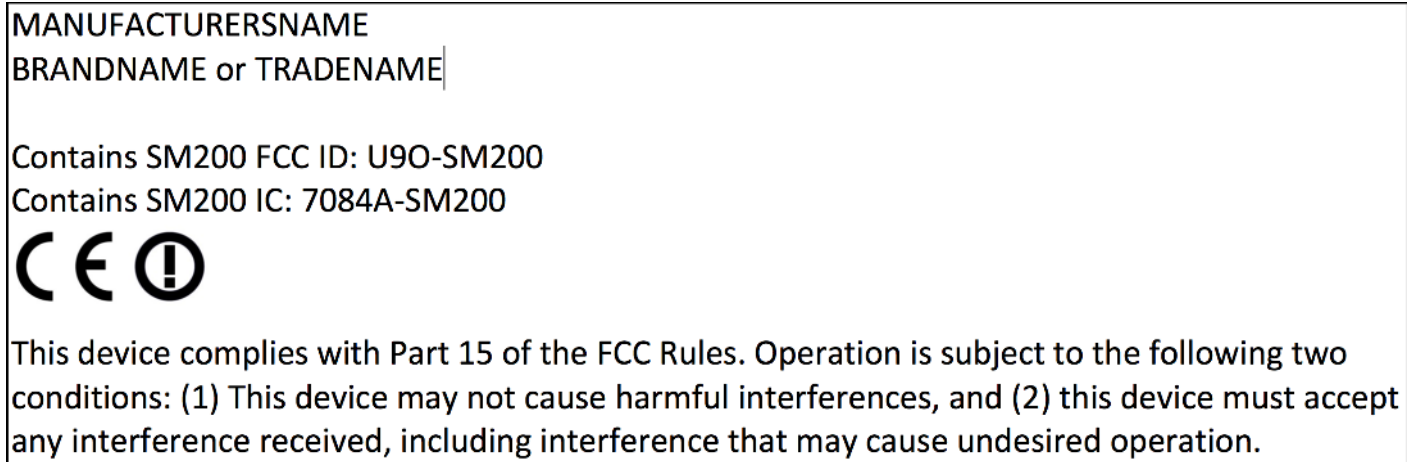

Fig. 4: Combined FCC, CE and IC Label