

## General Description

The 87946I-147 is a low skew, ÷1, ÷2 LVCMOS/LVTTL Fanout Buffer. The 87946I-147 has two selectable single ended clock inputs. The single ended clock inputs accept LVCMOS or LVTTL input levels. The low impedance LVCMOS/LVTTL outputs are designed to drive 50Ω series or parallel terminated transmission lines. The effective fanout can be increased from 10 to 20 by utilizing the ability of the outputs to drive two series terminated lines.

The divide select inputs, DIV\_SELx, control the output frequency of each bank. The outputs can be utilized in the ÷1, ÷2 or a combination of ÷1 and ÷2 modes. The master reset input, MR/nOE, resets the internal frequency dividers and also controls the active and high impedance states of all outputs.

The 87946I-147 is characterized at full 3.3V for input V<sub>DD</sub>, and mixed 3.3V and 2.5V for output operating supply mode. Guaranteed bank, output and part-to-part skew characteristics make the 87946I-147 ideal for those clock distribution applications demanding well defined performance and repeatability.

## Features

- Ten single ended LVCMOS/LVTTL outputs, 7Ω typical output impedance
- Selectable LVCMOS/LVTTL CLK0 and CLK1 inputs
- CLK0 and CLK1 can accept the following input levels: LVCMOS and LVTTL
- Maximum input frequency: 250MHz
- Bank skew: 30ps (maximum)
- Output skew: 175ps (maximum)
- Part-to-part skew: 850ps (maximum)
- Multiple frequency skew: 200ps (maximum)
- 3.3V core, 3.3V or 2.5V output supply modes
- -40°C to 85°C ambient operating temperature
- Lead-free packaging

## Block Diagram

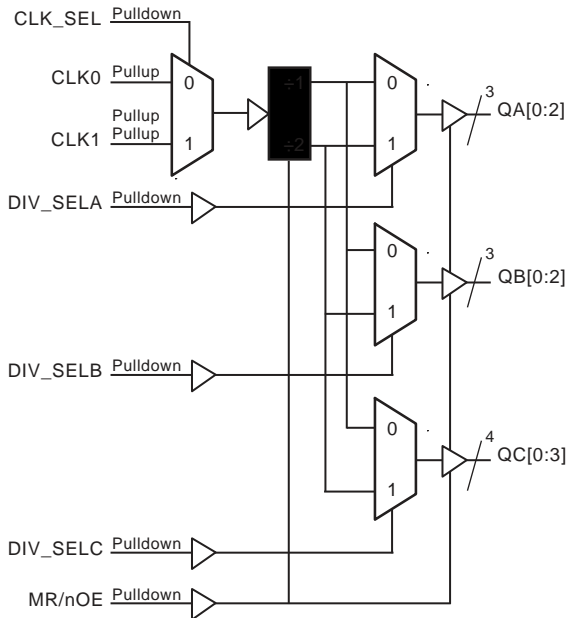

## Pin Assignment

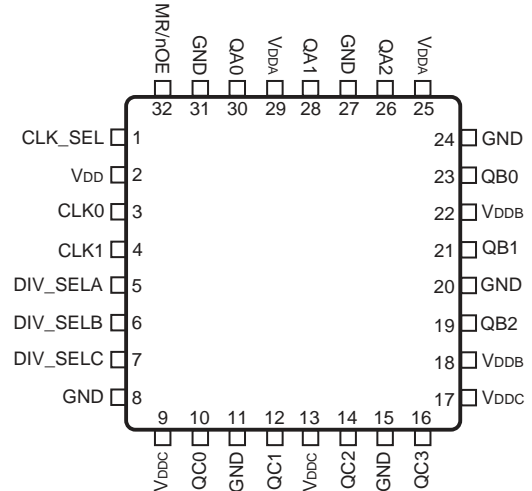

**87946I-147**  
**32-Lead LQFP**  
**7mm x 7mm x 1.4mm package body**  
**Y Package**  
**Top View**

## Pin Descriptions and Characteristics

**Table 1. Pin Descriptions**

Number	Name	Type		Description
1	CLK_SEL	Input	Pulldown	Clock select input. When HIGH, selects CLK1. When LOW, selects CLK0. LVCMOS / LVTTTL interface levels.
2	V <sub>DD</sub>	Power		Positive supply pin.
3, 4	CLK0, CLK1	Input	Pullup	Single-ended clock inputs. LVCMOS/LVTTTL interface levels.
5	DIV_SELA	Input	Pulldown	Controls frequency division for Bank A outputs. See Table 3 LVCMOS/LVTTTL interface levels.
6	DIV_SELB	Input	Pulldown	Controls frequency division for Bank B outputs. See Table 3. LVCMOS/LVTTTL interface levels.
7	DIV_SELC	Input	Pulldown	Controls frequency division for Bank C outputs. See Table 3. LVCMOS/LVTTTL interface levels.
8, 11, 15, 20, 24, 27, 31	GND	Power		Power supply ground.
9, 13, 17	V <sub>DDC</sub>	Power		Output supply pins for Bank C outputs.
10, 12, 14, 16	QC0, QC1, QC2, QC3	Output		Single-ended Bank C clock outputs. LVCMOS/LVTTTL interface levels. 7Ω typical output impedance.
18, 22	V <sub>DDB</sub>	Power		Output supply pins for Bank B outputs.
19, 21, 23	QB2, QB1, QB0	Output		Single-ended Bank B clock outputs. LVCMOS/LVTTTL interface levels. 7Ω typical output impedance.
25, 29	V <sub>DDA</sub>	Power		Output supply pins for Bank A outputs.
26, 28, 30	QA2, QA1, QA0	Output		Single-ended Bank A clock outputs. LVCMOS/LVTTTL interface levels. 7Ω typical output impedance.
32	MR/nOE	Input	Pulldown	Active HIGH Master Reset. Active LOW Output Enable. When logic HIGH, the internal dividers are reset and the outputs are (High-Impedance). When logic LOW, the internal dividers and the outputs are enabled. See Table 3. LVCMOS/LVTTTL interface levels.

NOTE: *Pullup* and *Pulldown* refer to internal input resistors. See Table 2, *Pin Characteristics*, for typical values.

**Table 2. Pin Characteristics**

Symbol	Parameter	Test Conditions	Minimum	Typical	Maximum	Units
C <sub>IN</sub>	Input Capacitance				4	pF
C <sub>PD</sub>	Power Dissipation Capacitance	V <sub>DD</sub> = V <sub>DDA</sub> = V <sub>DDB</sub> = V <sub>DDC</sub> = 3.6V		25		pF
R <sub>PULLUP</sub>	Input Pullup Resistor			51		kΩ
R <sub>PULLDOWN</sub>	Input Pulldown Resistor			51		kΩ
R <sub>OUT</sub>	Output Impedance			7		Ω

## Function Tables

Table 3. Clock Input Function Table

Inputs				Outputs		
MR/nOE	DIV_SELA	DIV_SELB	DIV_SELC	QA0:QA2	QB0:QB2	QC0:QC3
1	X	X	X	High-Impedance	High-Impedance	High-Impedance
0	0	X	X	$f_{IN}/1$	Active	Active
0	1	X	X	$f_{IN}/2$	Active	Active
0	X	0	X	Active	$f_{IN}/1$	Active
0	X	1	X	Active	$f_{IN}/2$	Active
0	X	X	0	Active	Active	$f_{IN}/1$
0	X	X	1	Active	Active	$f_{IN}/2$

## Absolute Maximum Ratings

NOTE: Stresses beyond those listed under *Absolute Maximum Ratings* may cause permanent damage to the device. These ratings are stress specifications only. Functional operation of the product at these conditions or any conditions beyond those listed in the *DC Characteristics* or *AC Characteristics* is not implied. Exposure to absolute maximum rating conditions for extended periods may affect product reliability.

Item	Rating
Supply Voltage, $V_{DD}$	4.6V
Inputs, $V_I$	-0.5V to $V_{DD} + 0.5V$
Outputs, $V_O$	-0.5V to $V_{DDX} + 0.5V$
Package Thermal Impedance, $\theta_{JA}$	47.9°C/W (0 lfpm)
Storage Temperature, $T_{STG}$	-65°C to 150°C
Junction Temperature	125°C

## DC Electrical Characteristics

Table 4A. Power Supply DC Characteristics,  $V_{DD} = V_{DDA} = V_{DDB} = V_{DDC} = 3.3V \pm 0.3V$ ,  $T_A = -40^\circ C$  to  $85^\circ C$

Symbol	Parameter	Test Conditions	Minimum	Typical	Maximum	Units
$V_{DD}$	Positive Supply Voltage		3.0	3.3	3.6	V
$V_{DDA}$ , $V_{DDB}$ , $V_{DDC}$	Output Supply Voltage		3.0	3.3	3.6	V
$I_{DD}$	Power Supply Current				55	mA
$I_{DDA}$ , $I_{DDB}$ , $I_{DDC}$	Output Supply Current				23	mA

**Table 4B. Power Supply DC Characteristics,  $V_{DD} = 3.3V \pm 5\%$ ,  $V_{DDA} = V_{DDB} = V_{DDC} = 2.5V \pm 5\%$ ,  $T_A = -40^\circ\text{C}$  to  $85^\circ\text{C}$** 

Symbol	Parameter	Test Conditions	Minimum	Typical	Maximum	Units
$V_{DD}$	Positive Supply Voltage		3.135	3.3	3.465	V
$V_{DDA}$ , $V_{DDB}$ , $V_{DDC}$	Output Supply Voltage		2.375	2.5	2.625	V
$I_{DD}$	Power Supply Current				55	mA
$I_{DDA}$ , $I_{DDB}$ , $I_{DDC}$	Output Supply Current				22	mA

**Table 4C. LVCMOS/LVTTL DC Characteristics,  $V_{DD} = V_{DDA} = V_{DDB} = V_{DDC} = 3.3V \pm 0.3V$ ,  $T_A = -40^\circ\text{C}$  to  $85^\circ\text{C}$** 

Symbol	Parameter	Test Conditions	Minimum	Typical	Maximum	Units
$V_{IH}$	Input High Voltage		2		$V_{DD} + 0.3$	V
$V_{IL}$	Input Low Voltage	MR/nOE, DIV_SELA, DIV_SELB, DIV_SEL, CLK_SEL	-0.3		0.8	V
		CLK0, CLK1	-0.3		1.3	V
$I_{IH}$	Input High Current	MR/nOE, DIV_SELA, DIV_SELB, DIV_SEL, CLK_SEL $V_{DD} = V_{IN} = 3.6V$			150	$\mu\text{A}$
		CLK0, CLK1 $V_{DD} = V_{IN} = 3.6V$			5	$\mu\text{A}$
$I_{IL}$	Input Low Current	MR/nOE, DIV_SELA, DIV_SELB, DIV_SEL, CLK_SEL $V_{DD} = 3.6V, V_{IN} = 0V$	-5			$\mu\text{A}$
		CLK0, CLK1 $V_{DD} = 3.6V, V_{IN} = 0V$	-150			$\mu\text{A}$
$V_{OH}$	Output High Voltage; NOTE 1	$V_{DDA} = V_{DDB} = V_{DDC} = 3.6V$	2.6			V
$V_{OL}$	Output Low Voltage; NOTE 1	$V_{DDA} = V_{DDB} = V_{DDC} = 3.63V$			0.5	V
$I_{OZL}$	Output Hi-Z Current Low	$V_{DDA} = V_{DDB} = V_{DDC} = 3.63V$	-5			$\mu\text{A}$
$I_{OZH}$	Output Hi-Z Current High	$V_{DDA} = V_{DDB} = V_{DDC} = 3.63V$			5	$\mu\text{A}$

NOTE 1: Outputs terminated with  $50\Omega$  to  $V_{DDx}/2$ . See Parameter Measurement Information section. *Load Test Circuit diagrams.*

**Table 4D. LVCMOS/LVTTL DC Characteristics,  $V_{DD} = 3.3V \pm 5\%$ ,  $V_{DDA} = V_{DDB} = V_{DDC} = 2.5V \pm 5\%$ ,  $T_A = -40^\circ\text{C}$  to  $85^\circ\text{C}$** 

Symbol	Parameter		Test Conditions	Minimum	Typical	Maximum	Units
$V_{IH}$	Input High Voltage			2		$V_{DD} + 0.3$	V
$V_{IL}$	Input Low Voltage	MR/nOE, DIV_SELA, DIV_SELB, DIV_SEL, CLK_SEL		-0.3		0.8	V
		CLK0, CLK1		-0.3		1.3	V
$I_{IH}$	Input High Current	MR/nOE, DIV_SELA, DIV_SELB, DIV_SEL, CLK_SEL	$V_{DD} = V_{IN} = 3.465V$			150	$\mu\text{A}$
		CLK0, CLK1	$V_{DD} = V_{IN} = 3.465V$			5	$\mu\text{A}$
$I_{IL}$	Input Low Current	MR/nOE, DIV_SELA, DIV_SELB, DIV_SEL, CLK_SEL	$V_{DD} = 3.465V, V_{IN} = 0V$	-5			$\mu\text{A}$
		CLK0, CLK1	$V_{DD} = 3.465V, V_{IN} = 0V$	-150			$\mu\text{A}$
$V_{OH}$	Output High Voltage; NOTE 1		$V_{DDA} = V_{DDB} = V_{DDC} = 2.625V$	1.8			V
$V_{OL}$	Output Low Voltage; NOTE 1		$V_{DDA} = V_{DDB} = V_{DDC} = 2.625V$			0.5	V
$I_{OZL}$	Output Hi-Z Current Low		$V_{DDA} = V_{DDB} = V_{DDC} = 2.625V$	-5			$\mu\text{A}$
$I_{OZH}$	Output Hi-Z Current High		$V_{DDA} = V_{DDB} = V_{DDC} = 2.625V$			5	$\mu\text{A}$

NOTE 1: Outputs terminated with  $50\Omega$  to  $V_{DDx}/2$ . See Parameter Measurement Information section. *Load Test Circuit diagrams.*

## AC Electrical Characteristics

**Table 5A. AC Characteristics,  $V_{DD} = V_{DDA} = V_{DDB} = V_{DDC} = 3.3V \pm 0.3V$ ,  $T_A = -40^{\circ}C$  to  $85^{\circ}C$**

Symbol	Parameter	Test Conditions	Minimum	Typical	Maximum	Units
$f_{MAX}$	Output Frequency				250	MHz
$t_{PD}$	Propagation Delay; NOTE 1	$f \leq 250MHz$	2		5	ns
$t_{sk}(b)$	Bank Skew, NOTE 2, 7	Measured on rising edge at $V_{DDX}/2$			30	ps
$t_{sk}(o)$	Output Skew; NOTE 3, 7	Measured on rising edge at $V_{DDX}/2$			175	ps
$t_{sk}(w)$	Multiple Frequency Skew; NOTE 4, 7	Measured on rising edge at $V_{DDX}/2$			275	ps
$t_{sk}(pp)$	Part-to-Part Skew; NOTE 5, 7	Measured on rising edge at $V_{DDX}/2$			850	ps
$t_R / t_F$	Output Rise/Fall Time; NOTE 6	20% to 80%	400		950	ps
$t_{PW}$	Output Pulse Width		$t_{PERIOD}/2 - 1$	$t_{PERIOD}/2$	$t_{PERIOD}/2 + 1$	%
$t_{EN}$	Output Enable Time; NOTE 6	$f = 10MHz$			3	ns
$t_{DIS}$	Output Disable Time; NOTE 6	$f = 10MHz$			3	ns

NOTE: Electrical parameters are guaranteed over the specified ambient operating temperature range, which is established when the device is mounted in a test socket with maintained transverse airflow greater than 500 lfm. The device will meet specifications after thermal equilibrium has been reached under these conditions.

NOTE 1: Measured from  $V_{DD}/2$  of the input to  $V_{DDX}/2$  of the output.

NOTE 2: Defined as skew within a bank of outputs at the same supply voltage and with equal load conditions.

NOTE 3: Defined as skew across banks of outputs at the same supply voltage and with equal load conditions. Measured at  $V_{DDX}/2$ .

NOTE 4: Defined as skew across banks of outputs operating at different frequencies with the same supply voltage and equal load conditions.

NOTE 5: Defined as skew between outputs on different devices operating at the same supply voltage and with equal load conditions. Using the same type of inputs on each device, the outputs are measured at  $V_{DDX}/2$ .

NOTE 6: These parameters are guaranteed by characterization. Not tested in production.

NOTE 7: This parameter is defined in accordance with JEDEC Standard 65.

**Table 5B. AC Characteristics,  $V_{DD} = 3.3V \pm 5\%$ ,  $V_{DDA} = V_{DDB} = V_{DDC} = 2.5V \pm 5\%$ ,  $T_A = -40^{\circ}C$  to  $85^{\circ}C$** 

Symbol	Parameter	Test Conditions	Minimum	Typical	Maximum	Units
$f_{MAX}$	Output Frequency				250	MHz
$t_{PD}$	Propagation Delay; NOTE 1	$f \leq 250MHz$	2		5	ns
$t_{sk(b)}$	Bank Skew, NOTE 2, 7	Measured on rising edge at $V_{DDX}/2$			35	ps
$t_{sk(o)}$	Output Skew; NOTE 3, 7	Measured on rising edge at $V_{DDX}/2$			175	ps
$t_{sk(w)}$	Multiple Frequency Skew; NOTE 4, 7	Measured on rising edge at $V_{DDX}/2$			200	ps
$t_{sk(pp)}$	Part-to-Part Skew; NOTE 5, 7	Measured on rising edge at $V_{DDX}/2$			875	ps
$t_R / t_F$	Output Rise/Fall Time; NOTE 6	20% to 80%	400		950	ps
$t_{PW}$	Output Pulse Width		$t_{PERIOD}/2 - 1$	$t_{PERIOD}/2$	$t_{PERIOD}/2 + 1$	%
$t_{EN}$	Output Enable Time; NOTE 6	$f = 10MHz$			3	ns
$t_{DIS}$	Output Disable Time; NOTE 6	$f = 10MHz$			3	ns

NOTE: Electrical parameters are guaranteed over the specified ambient operating temperature range, which is established when the device is mounted in a test socket with maintained transverse airflow greater than 500 lfm. The device will meet specifications after thermal equilibrium has been reached under these conditions.

NOTE 1: Measured from  $V_{DD}/2$  of the input to  $V_{DDX}/2$  of the output.

NOTE 2: Defined as skew within a bank of outputs at the same supply voltage and with equal load conditions.

NOTE 3: Defined as skew across banks of outputs at the same supply voltage and with equal load conditions. Measured at  $V_{DDX}/2$ .

NOTE 4: Defined as skew across banks of outputs operating at different frequencies with the same supply voltage and equal load conditions.

NOTE 5: Defined as skew between outputs on different devices operating at the same supply voltage and with equal load conditions. Using the same type of inputs on each device, the outputs are measured at  $V_{DDX}/2$ .

NOTE 6: These parameters are guaranteed by characterization. Not tested in production.

NOTE 7: This parameter is defined in accordance with JEDEC Standard 65.

## Parameter Measurement Information

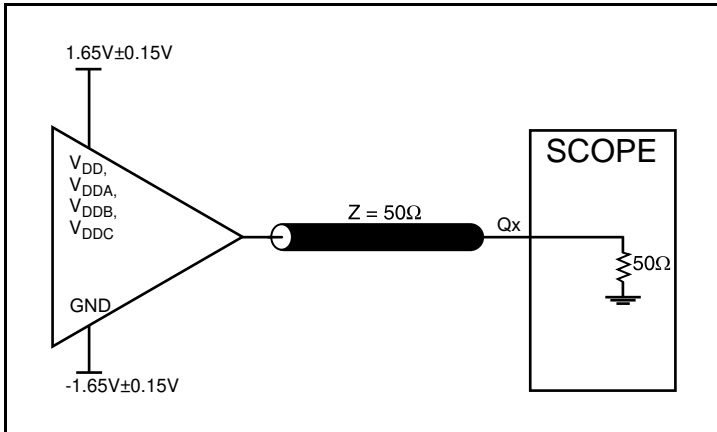

3.3V Core/3.3V Output Load AC Test Circuit

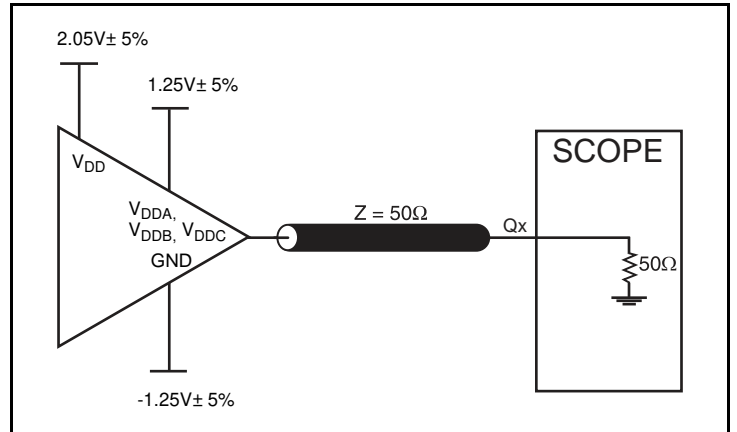

3.3V Core/2.5V Output Load AC Test Circuit

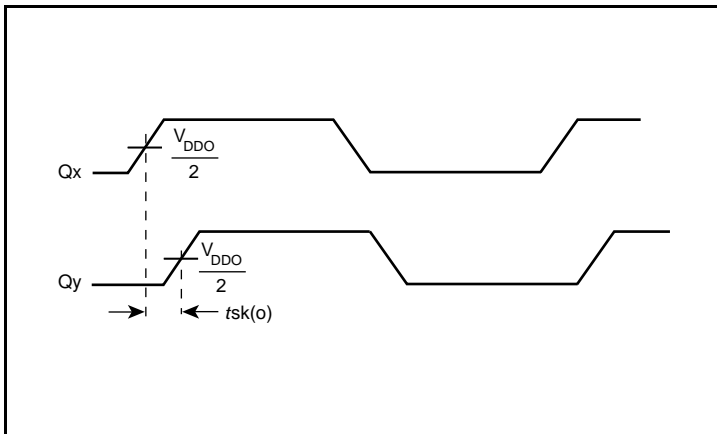

Output Skew

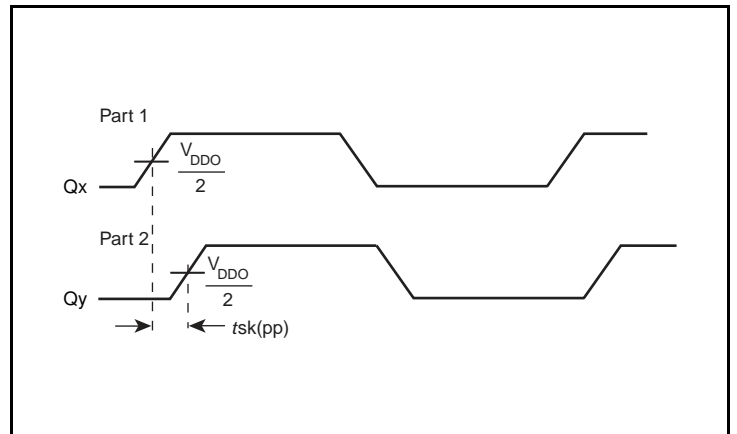

Part-to-Part Skew

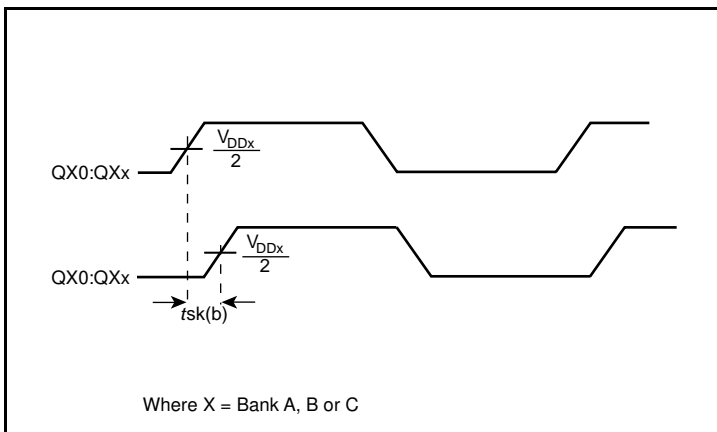

Bank Skew

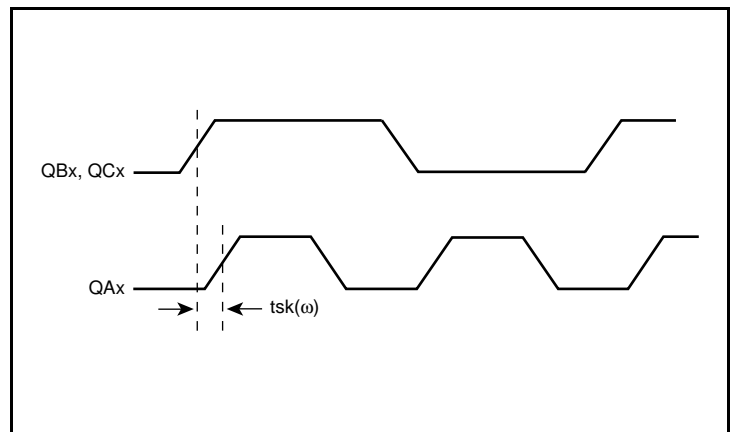

Multiple Frequency Skew



Parameter Measurement Information, continued

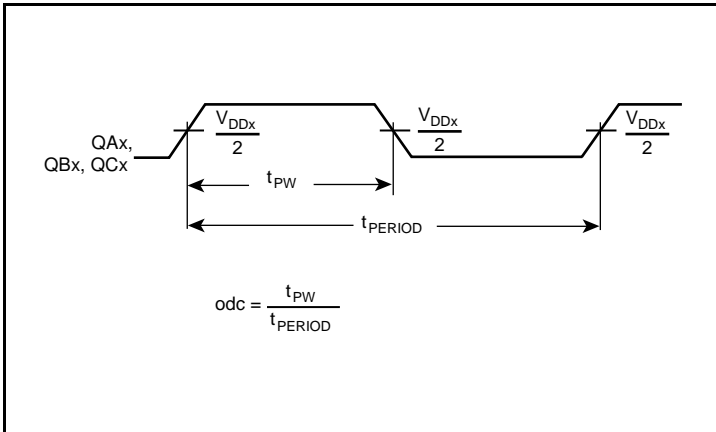

$t_{PW}$  &  $t_{PERIOD}$

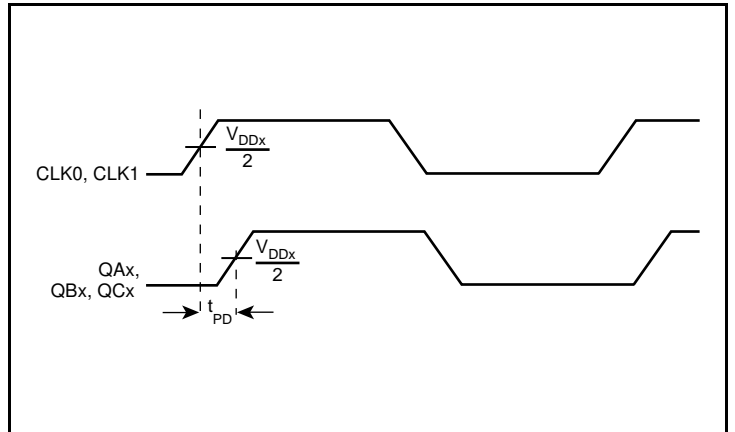

Propagation Delay

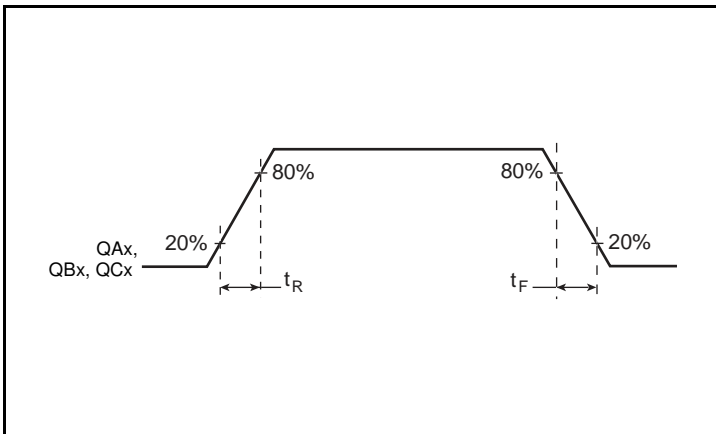

Output Rise/Fall Time

## Applications Information

### Recommendations for Unused Input and Output Pins

#### Inputs:

##### LVC MOS Control Pins

All control pins have internal pulldowns; additional resistance is not required but can be added for additional protection. A 1k $\Omega$  resistor can be used.

##### CLK Inputs

For applications not requiring the use of a clock input, it can be left floating. Though not required, but for additional protection, a 1k $\Omega$  resistor can be tied from the CLK input to ground.

#### Outputs:

##### LVC MOS Outputs

All unused LVC MOS output can be left floating. There should be no trace attached.

## Reliability Information

**Table 6.  $\theta_{JA}$  vs. Air Flow Table for a 32-Lead LQFP**

$\theta_{JA}$ vs. Air Flow			
Linear Feet per Minute	0	200	500
Single-Layer PCB, JEDEC Standard Test Boards	67.8°C/W	55.9°C/W	50.1°C/W
Multi-Layer PCB, JEDEC Standard Test Boards	47.9°C/W	42.1°C/W	39.4°C/W
NOTE: Most modern PCB designs use multi-layered boards. The data in the second row pertains to most designs.			

### Transistor Count

The transistor count for 87946I-147 is: 1204  
Pin compatible to the MPC9446 and MPC946

# Package Outline and Package Dimensions

## Package Outline - Y Suffix for 32-Lead LQFP

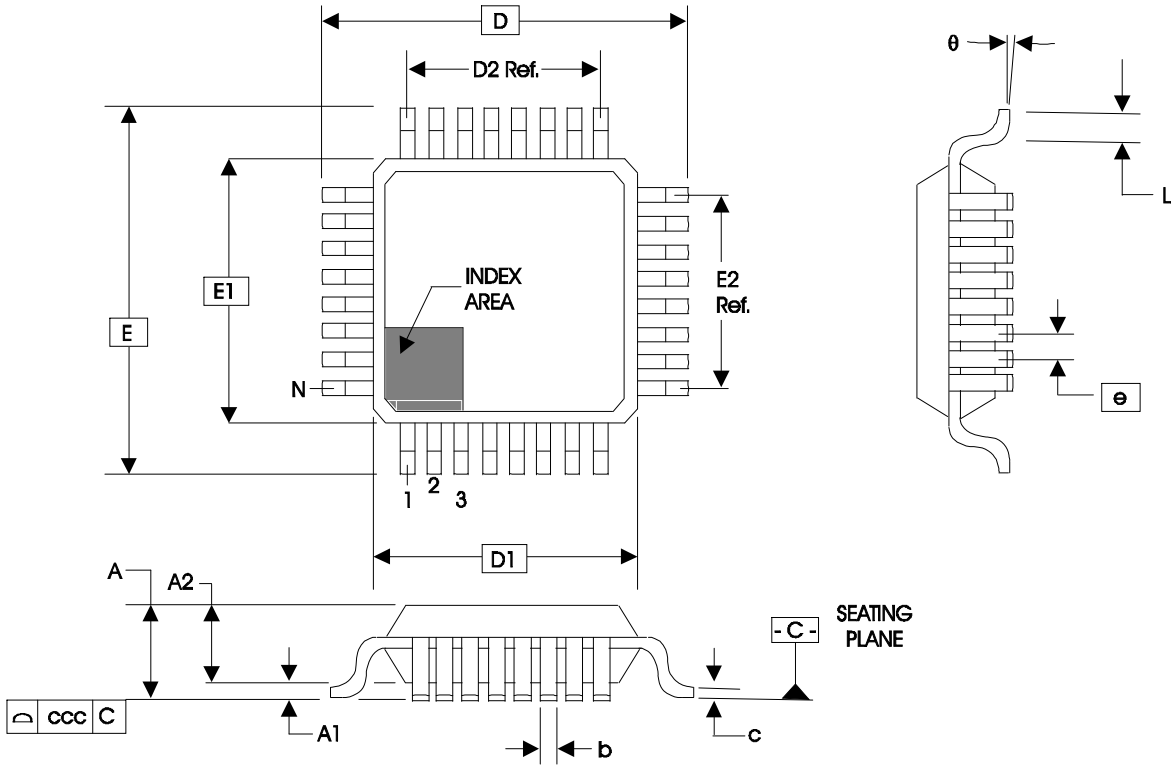

Table 7. Package Dimensions for 32-Lead LQFP

JEDEC Variation: BBC - HD			
All Dimensions in Millimeters			
Symbol	Minimum	Nominal	Maximum
N	32		
A			1.60
A1	0.05	0.10	0.15
A2	1.35	1.40	1.45
b	0.30	0.37	0.45
c	0.09		0.20
D & E	9.00 Basic		
D1 & E1	7.00 Basic		
D2 & E2	5.60 Ref.		
e	0.80 Basic		
L	0.45	0.60	0.75
$\theta$	0°		7°
ccc			0.10

Reference Document: JEDEC Publication 95, MS-026

## Ordering Information

Table 8. Ordering Information

Part/Order Number	Marking	Package	Shipping Packaging	Temperature
87946AYI-147LF	ICS7946AI147L	"Lead-Free" 32-Lead LQFP	Tray	-40°C to 85°C
87946AYI-147LFT	ICS7946AI147L	"Lead-Free" 32-Lead LQFP	Tape & Reel	-40°C to 85°C
87946AYI-147LF/W	ICS7946AI147L	"Lead-Free" 32-Lead LQFP	Tape & Reel, Pin1 Orientation: EIA-481-D	-40°C to 85°C

## Revision History Sheet

Rev	Table	Page	Description of Change	Date
A	T2  T8	1 2 8  10 12	Features section added <i>Lead-Free</i> bullet. Pin Description Table - corrected description for $V_{DDA}$ , $V_{DDB}$ and $V_{DDC}$ . Parameter Measurement Information Section - added part-to-part skew, bank skew, and multiple frequency skew diagrams. Application Section - added <i>Recommendations for Unused Input and Output Pins</i> . Ordering Information Table - added lead-free marking. Updated format throughout the datasheet.	7/22/08
A	T5A - T5B T8	6 - 7 12	AC Tables - added thermal note. Ordering Information Table - corrected the Part/Order Numbers and corrected the non-LF marking. Updated Header/Footer of the datasheet.	8/7/09
A	T8	12	Removed leaded orderable parts from Ordering Information table	11/15/12
A	T8	12 14	Ordering Information Table - Added 87946AYI-147LF/W Ordering option. Updated Technical Support Contact Info to: clocks@idt.com	4/30/14
B		3	Absolute Maximum Ratings Table - added Junction Temperature. Updated datasheet header/footer. Deleted "ICS" prefix from part number.	2/24/16
C		1	Corrected datasheet title. Corrected <i>General Description</i> , first sentence from <i>Clock Generator</i> to <i>Fanout Buffer</i> .	



## IMPORTANT NOTICE AND DISCLAIMER

RENESAS ELECTRONICS CORPORATION AND ITS SUBSIDIARIES (“RENESAS”) PROVIDES TECHNICAL SPECIFICATIONS AND RELIABILITY DATA (INCLUDING DATASHEETS), DESIGN RESOURCES (INCLUDING REFERENCE DESIGNS), APPLICATION OR OTHER DESIGN ADVICE, WEB TOOLS, SAFETY INFORMATION, AND OTHER RESOURCES “AS IS” AND WITH ALL FAULTS, AND DISCLAIMS ALL WARRANTIES, EXPRESS OR IMPLIED, INCLUDING, WITHOUT LIMITATION, ANY IMPLIED WARRANTIES OF MERCHANTABILITY, FITNESS FOR A PARTICULAR PURPOSE, OR NON-INFRINGEMENT OF THIRD PARTY INTELLECTUAL PROPERTY RIGHTS.

These resources are intended for developers skilled in the art designing with Renesas products. You are solely responsible for (1) selecting the appropriate products for your application, (2) designing, validating, and testing your application, and (3) ensuring your application meets applicable standards, and any other safety, security, or other requirements. These resources are subject to change without notice. Renesas grants you permission to use these resources only for development of an application that uses Renesas products. Other reproduction or use of these resources is strictly prohibited. No license is granted to any other Renesas intellectual property or to any third party intellectual property. Renesas disclaims responsibility for, and you will fully indemnify Renesas and its representatives against, any claims, damages, costs, losses, or liabilities arising out of your use of these resources. Renesas' products are provided only subject to Renesas' Terms and Conditions of Sale or other applicable terms agreed to in writing. No use of any Renesas resources expands or otherwise alters any applicable warranties or warranty disclaimers for these products.

(Disclaimer Rev.1.0 Mar 2020)

### Corporate Headquarters

TOYOSU FORESIA, 3-2-24 Toyosu,  
Koto-ku, Tokyo 135-0061, Japan  
[www.renesas.com](http://www.renesas.com)

### Contact Information

For further information on a product, technology, the most up-to-date version of a document, or your nearest sales office, please visit:  
[www.renesas.com/contact/](http://www.renesas.com/contact/)

### Trademarks

Renesas and the Renesas logo are trademarks of Renesas Electronics Corporation. All trademarks and registered trademarks are the property of their respective owners.