

SURFACE MOUNT SILICON RECTIFIER

VOLTAGE RANGE 50 to 1000 Volts CURRENT 1.0 Ampere

FEATURES

- * Ideal for surface mounted applications
- * Low leakage current
- * Metallurgically bonded construction
- * Mounting position: Any
- * Weight: 0.078 gram

MECHANICAL DATA

- * Epoxy : Device has UL flammability classification 94V-0

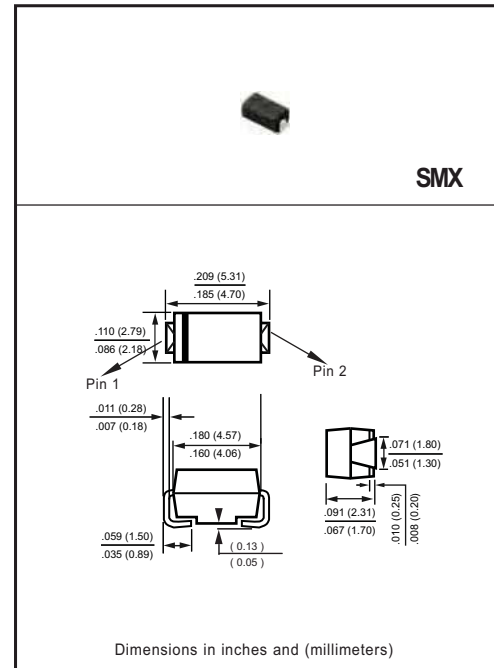

MAXIMUM RATINGS AND ELECTRICAL CHARACTERISTICS

Ratings at 25°C ambient temperature unless otherwise specified.
Single phase, half wave, 60 Hz, resistive or inductive load.
For capacitive load, derate current by 20%.

MAXIMUM RATINGS (@ TA=25 °C unless otherwise noted)

RATINGS	SYMBOL	FM4001W	FM4002W	FM4003W	FM4004W	FM4005W	FM4006W	FM4007W	UNITS
Maximum Recurrent Peak Reverse Voltage	V_{RRM}	50	100	200	400	600	800	1000	Volts
Maximum RMS Voltage	V_{RMS}	35	70	140	280	420	560	700	Volts
Maximum DC Blocking Voltage	V_{DC}	50	100	200	400	600	800	1000	Volts
Maximum Average Forward Rectified Current at Ambient Temperature	I_O	1.0							Amps
Peak Forward Surge Current 8.3 ms single half sine-wave superimposed on rated load (JEDEC method)	I_{FSM}	30							Amps
Typical Thermal Resistance (Note 1)	$R_{\theta JA}$	80							°C/W
Typical Thermal Resistance (Note 1)	$R_{\theta JL}$	30							°C/W
Typical Current Squared Time	I^2T	3.74							A ² S
Typical Junction Capacitance (Note 2)	C_J	15							pF
Operating Temperature Range	T_J	-55 to + 150							°C
Storage Temperature Range	T_{STG}	-55 to + 150							°C

ELECTRICAL CHARACTERISTICS (@TA=25 °C unless otherwise noted)

CHARACTERISTICS	SYMBOL	FM4001W	FM4002W	FM4003W	FM4004W	FM4005W	FM4006W	FM4007W	UNITS
Maximum Instantaneous Forward Voltage at 1.0A DC	V_F	1.1							Volts
Maximum Full Load Reverse Current, Full cycle Average at $T_A=75^\circ\text{C}$	I_R	30							uA
Maximum Average Reverse Current @ $T_A = 25^\circ\text{C}$		5.0							uA
at Rated DC Blocking Voltage @ $T_A = 150^\circ\text{C}$		2.0							mA

- NOTES : 1. Thermal Resistance :Mounted on PCB.
2. Measured at 1 MHz and applied reverse voltage of 4.0 volts.
3. "ROHS compliant".

RATING AND CHARACTERISTICS CURVES (FM4001W THRU FM4007W)

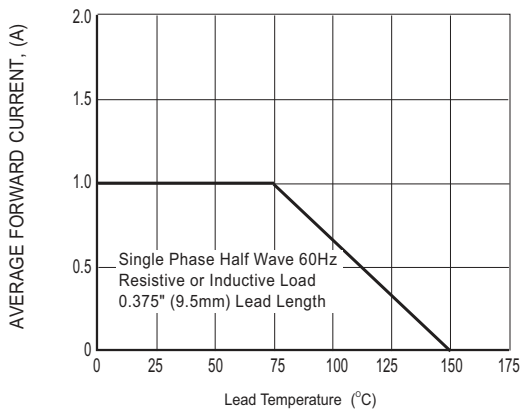

FIG.1 TYPICAL FORWARD CURRENT DERATING CURVE

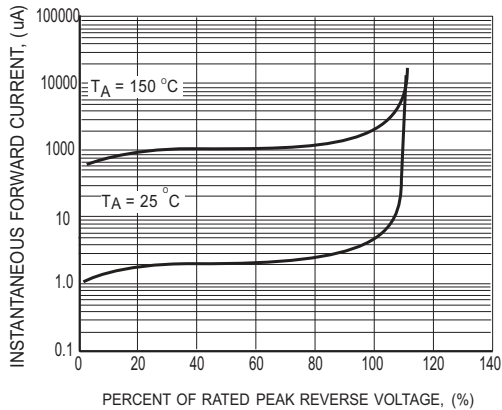

FIG.2 MAXIMUM REVERSE CHARACTERISTICS

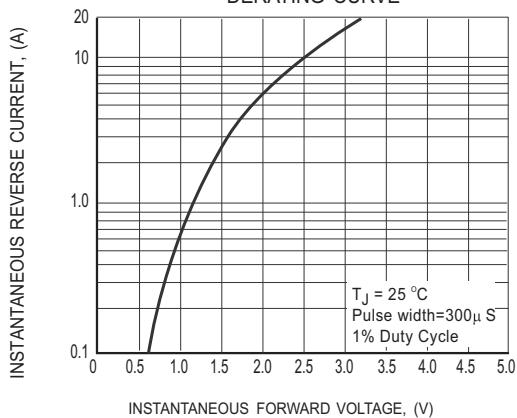

FIG.3 MAXIMUM INSTANTANEOUS FORWARD CHARACTERISTICS

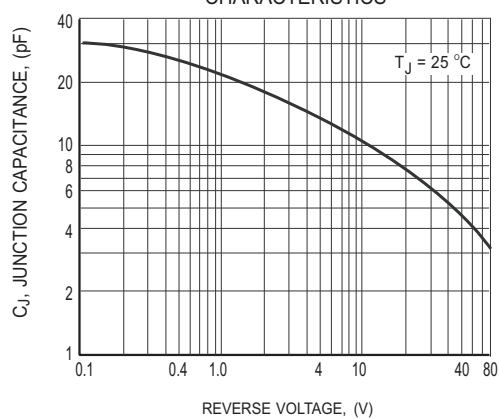

FIG.4 TYPICAL JUNCTION CAPACITANCE

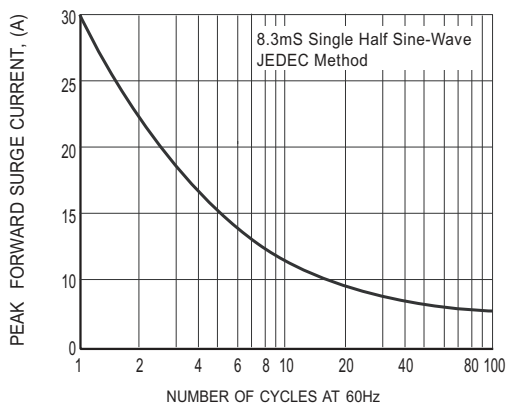
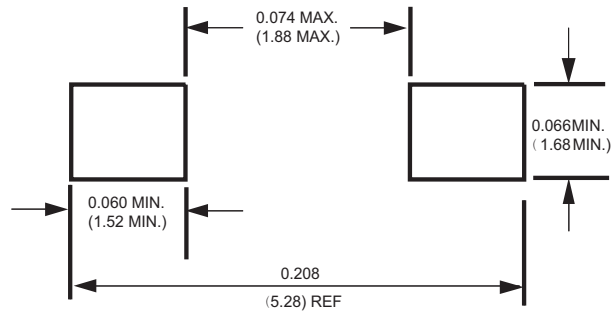

FIG.5 MAXIMUM NON-REPETITIVE FORWARD SURGE CURRENT



Mounting Pad Layout



Dimensions in inches and (millimeters)



Attachment information about FM400XW

1. Internal Circuit



2. Marking on the body

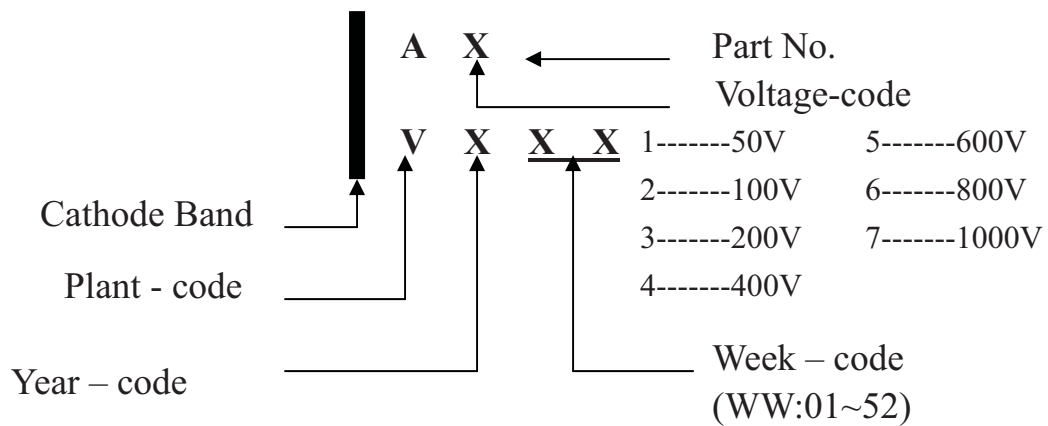

(Y: Last digit of year &
A:2010,B:2011.....)

REEL TAPING SPECIFICATIONS FOR SURFACE MOUNT DEVICES-FLAT MELF (SMA/SMB/SMC/SMX)

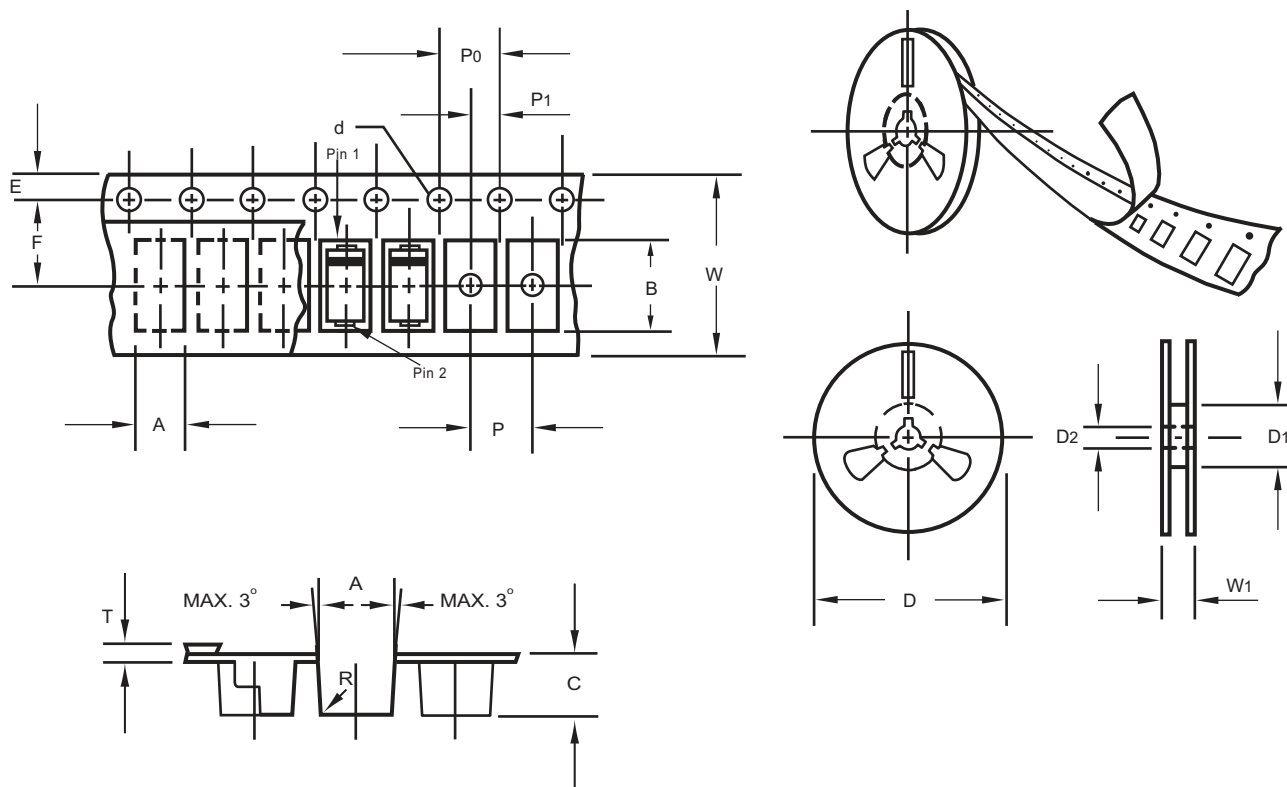

Fig.: Configuration of FLAT MELF TAPING
(SMA/SMB/SMC/SMX)

ITEM	SYMBOL	DO214AC (SMA) mm(inch)	DO214AA (SMB) mm(inch)	DO214AB (SMC) mm(inch)
Carrier width	A	2.6 ± 0.15 (0.102 ± 0.006)	3.65 ± 0.1 (0.144 ± 0.004)	6.0 ± 0.1 (0.236 ± 0.004)
Carrier length	B	5.15 ± 0.15 (0.203 ± 0.006)	5.69 ± 0.1 (0.224 ± 0.004)	8.30 ± 0.1 (0.327 ± 0.004)
Carrier depth	C	2.3 ± 0.15 (0.091 ± 0.006)	2.67 ± 0.1 (0.105 ± 0.004)	2.5 ± 0.1 (0.098 ± 0.004)
Sprocket hole	d	1.5 ± 0.1 (0.059 ± 0.004)	1.5 ± 0.1 (0.059 ± 0.004)	1.5 ± 0.1 (0.059 ± 0.004)
Reel outside diameter	D	178 ± 2.0 (7.0 ± 0.079)	178 ± 2.0 (7.0 ± 0.079)	178 ± 2.0 (7.0 ± 0.079)
Reel inner diameter	D1	50 Min.	50 Min.	50 Min.
Feed hole diameter	D2	13 ± 0.5 (0.512 ± 0.020)	13 ± 0.5 (0.512 ± 0.020)	13 ± 0.5 (0.512 ± 0.020)
Sprocket hole position	E	1.75 ± 0.1 (0.059 ± 0.004)	1.75 ± 0.1 (0.059 ± 0.004)	1.75 ± 0.1 (0.059 ± 0.004)
Punch hole position	F	5.65 ± 0.05 (0.222 ± 0.002)	5.65 ± 0.05 (0.222 ± 0.002)	7.5 ± 0.05 (0.301 ± 0.002)
Punch hole pitch	P	4.0 ± 0.1 (0.157 ± 0.004)	8.0 ± 0.1 (0.315 ± 0.004)	8.0 ± 0.1 (0.315 ± 0.004)
Sprocket hole pitch	P0	4.0 ± 0.1 (0.157 ± 0.004)	4.0 ± 0.1 (0.157 ± 0.004)	4.0 ± 0.1 (0.157 ± 0.004)
Embossment center	P1	2.0 ± 0.1 (0.079 ± 0.004)	2.0 ± 0.1 (0.079 ± 0.004)	2.0 ± 0.1 (0.157 ± 0.004)
Total tape thickness	T	0.30 ± 0.05 (0.012 ± 0.002)	0.6 Max.	0.6 Max.
Tape width	W	12.0 ± 0.2 (0.472 ± 0.008)	12.0 ± 0.2 (0.472 ± 0.008)	16.0 ± 0.2 (0.630 ± 0.008)
Reel width	W1	16.8 ± 2.0 (0.661 ± 0.079)	16.8 ± 2.0 (0.661 ± 0.079)	24.0 ± 2.0 (0.945 ± 0.079)

Note: 1.Devices are packed in accordance with EIA standard RS-481-D and specification given above.
2.Available on 7 inch (1500 ct.) or 13 inch (5000 ct.) diameter reels.

Visit [http:// www.rectron.com](http://www.rectron.com) for complete datasheets

PACKAGING OF DIODE AND BRIDGE RECTIFIERS

REEL PACK

PACKAGE	PACKING CODE	EA PER REEL	EA PER INNER BOX	COMPONENT SPACE (mm)	TAPE SPACE (mm)	REEL DIA (mm)	CARTON SIZE (mm)	EA PER CARTON	GROSS WEIGHT(Kg)
SMX	-W	7,500	15,000	---	---	330	360*355*360	120,000	15.2

PACKAGE	PACKING CODE	EA PER REEL	EA PER INNER BOX	COMPONENT SPACE (mm)	TAPE SPACE (mm)	REEL DIA (mm)	CARTON SIZE (mm)	EA PER CARTON	GROSS WEIGHT(Kg)
SMX	-T	2,000	8,000	---	---	178	390*205*310	64,000	7.8

DISCLAIMER NOTICE

Rectron Inc reserves the right to make changes without notice to any product specification herein, to make corrections, modifications, enhancements or other changes. Rectron Inc or anyone on its behalf assumes no responsibility or liability for any errors or inaccuracies. Data sheet specifications and its information contained are intended to provide a product description only. "Typical" parameters which may be included on RECTRON data sheets and/ or specifications can and do vary in different applications and actual performance may vary over time. Rectron Inc does not assume any liability arising out of the application or use of any product or circuit.

Rectron products are not designed, intended or authorized for use in medical, life-saving implant or other applications intended for life-sustaining or other related applications where a failure or malfunction of component or circuitry may directly or indirectly cause injury or threaten a life without expressed written approval of Rectron Inc. Customers using or selling Rectron components for use in such applications do so at their own risk and shall agree to fully indemnify Rectron Inc and its subsidiaries harmless against all claims, damages and expenditures.