

PART NUMBER	REV	TERMINATOR	FEED TYPE	DESCRIPTION
1528700-1	A	LEADMAKER	MECH POST FEED	CUTS CARRIER
1528700-2	A	BENCH	MECH PRE FEED	CUTS CARRIER
1528700-6	A	LEADMAKER	MECH POST FEED	CONTINUOUS CARRIER
7-1528700-1	A	LEADMAKER	MECH POST FEED	-1 AND SPARE PARTS
7-1528700-2	A	BENCH	MECH PRE FEED	-2 AND SPARE PARTS
7-1528700-6	A	LEADMAKER	MECH POST FEED	-6 AND SPARE PARTS
7-1528700-7	A	-	-	SPARE PARTS KIT

CRIMP DATA	TYCO TERMINAL	TYCO CRIMP SPECS
TERMINAL NAME: PIN / SOCKET SIZE 20 DF		
CRIMP	SIZE	TYPE
WIRE	1.07 [1.042 IN]	F
INSUL	1.57 [1.062 IN]	O
RANGE 28-24 AWG		
WIRE STRIP LENGTH 2.13-2.64 [1.084-1.104 IN]		
APPL INSTRUCTIONS 408-8322 & 408-8490		
TERMINAL APPL SPEC 114-10000		FEED 7.62 [1.300 IN]
TERMINALS APPLIED		
PIN	SOCKET	
66682	66683	-
5066682	5066683	-
-	-	-
-	-	-
WIRE SIZE	CRIMP HEIGHT	REF SETTING
24 AWG	0.81 ± 0.03 [1.032 ± 0.001 IN]	C 2
26 AWG	0.74 ± 0.03 [1.029 ± 0.001 IN]	C 8
28 AWG	0.66 ± 0.03 [1.026 ± 0.001 IN]	D 3

- RECOMMENDED SPARE PARTS.
- GREASE RAM, CAM, CAM FOLLOWER AND FEED ROD LIGHTLY.
- CERTAIN TERMINALS REQUIRE LUBRICATION. REFER TO THE APPLICATOR INSTRUCTION SHEET FOR MORE INFORMATION.
- LUBRICATE DAILY PER THE APPLICATOR INSTRUCTION SHEET SUPPLIED WITH THE APPLICATOR.

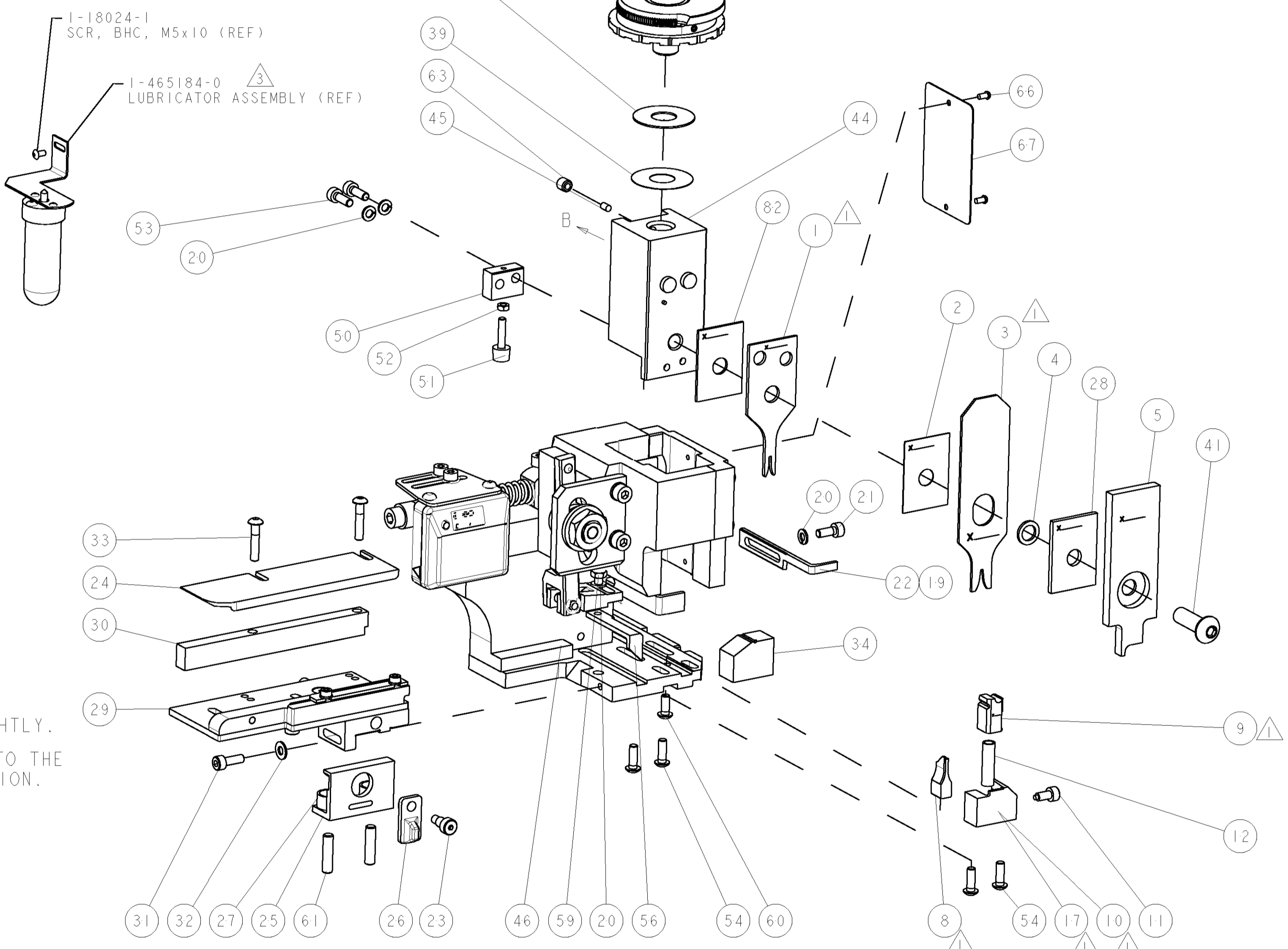

*** WARNING**
 ON INSTALLATION, SET WIRE DISC TO LARGEST WIRE SIZE SETTING. USE OF SETTINGS BELOW MIN. REQUIRED CRIMP HEIGHT SETTING WILL CAUSE DAMAGE TO CRIMP TOOLING.

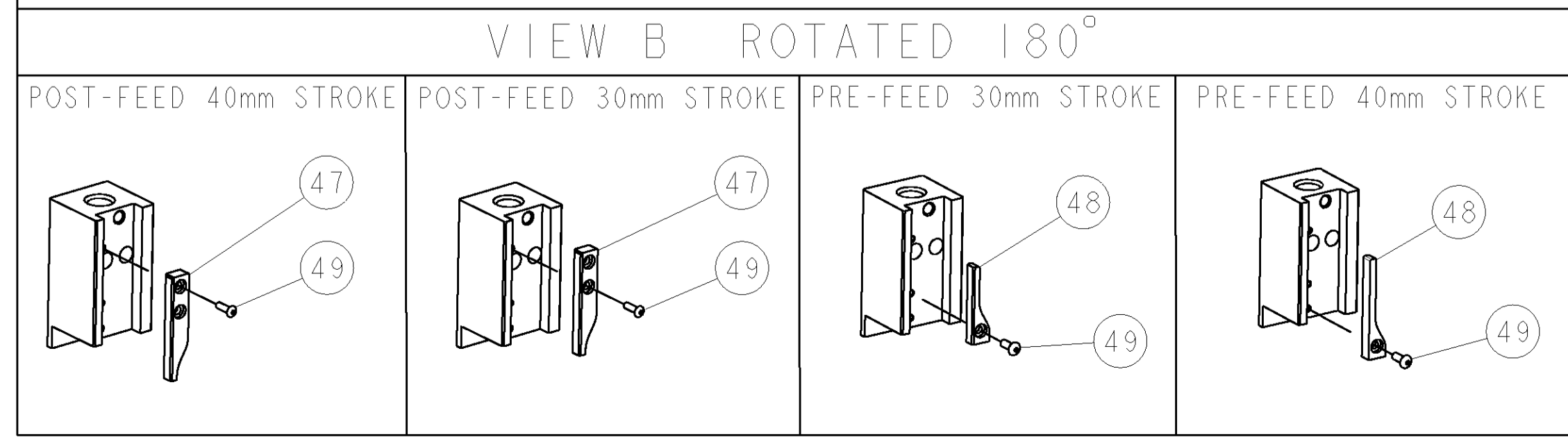

QTY	DESCRIPTION	ITEM NO
-	-	84
-	-	83
-	-	82
-	-	81
-	-	80
-	-	79
-	-	78
-	-	77
-	-	76
-	-	75
-	-	74
-77 -76 -72 -71 -6 -2 -1	PART NO	DESCRIPTION

SET UP GAGE 458637-3		LOC A	DIST 66	REVISIONS			
REV	DATE	BY	CHK	DESCRIPTION	DATE	BY	APPR
A	180CT2006	LJL	MC	SEE ECO-06-024469			

QTY	DESCRIPTION	ITEM NO
-	-	73
-	-	72
-	-	71
-	-	70
-	-	69
-	-	68
-	-	67
-	-	66
-	-	65
-	-	64
-	-	63
-	-	62
-	-	61
-	-	60
-	-	59
-	-	58
-	-	57
-	-	56
-	-	55
-	-	54
-	-	53
-	-	52
-	-	51
-	-	50
-	-	49
-	-	48
-	-	47
-	-	46
-	-	45
-	-	44
-	-	43
-	-	42
-	-	41
-	-	40
-	-	39
-	-	38
-	-	37
-	-	36
-	-	35
-	-	34
-	-	33
-	-	32
-	-	31
-	-	30
-	-	29
-	-	28
-	-	27
-	-	26
-	-	25
-	-	24
-	-	23
-	-	22
-	-	21
-	-	20
-	-	19
-	-	18
-	-	17
-	-	16
-	-	15
-	-	14
-	-	13
-	-	12
-	-	11
-	-	10
-	-	9
-	-	8
-	-	7
-	-	6
-	-	5
-	-	4
-	-	3
-	-	2
-	-	1
-77 -76 -72 -71 -6 -2 -1	PART NO	DESCRIPTION

QTY	DESCRIPTION	ITEM NO
-	-	84
-	-	83
-	-	82
-	-	81
-	-	80
-	-	79
-	-	78
-	-	77
-	-	76
-	-	75
-	-	74
-77 -76 -72 -71 -6 -2 -1	PART NO	DESCRIPTION

QTY	DESCRIPTION	ITEM NO
-	-	84
-	-	83
-	-	82
-	-	81
-	-	80
-	-	79
-	-	78
-	-	77
-	-	76
-	-	75
-	-	74
-77 -76 -72 -71 -6 -2 -1	PART NO	DESCRIPTION

QTY	DESCRIPTION	ITEM NO
-	-	84
-	-	83
-	-	82
-	-	81
-	-	80
-	-	79
-	-	78
-	-	77
-	-	76
-	-	75
-	-	74
-77 -76 -72 -71 -6 -2 -1	PART NO	DESCRIPTION

QTY	DESCRIPTION	ITEM NO
-	-	84
-	-	83
-	-	82
-	-	81
-	-	80
-	-	79
-	-	78
-	-	77
-	-	76
-	-	75
-	-	74
-77 -76 -72 -71 -6 -2 -1	PART NO	DESCRIPTION

QTY	DESCRIPTION	ITEM NO
-	-	84
-	-	83
-	-	82
-	-	81
-	-	80
-	-	79
-	-	78
-	-	77
-	-	76
-	-	75
-	-	74
-77 -76 -72 -71 -6 -2 -1	PART NO	DESCRIPTION

QTY	DESCRIPTION	ITEM NO
-	-	84
-	-	83
-	-	82
-	-	81
-	-	80
-	-	79
-	-	78
-	-	77
-	-	76
-	-	75
-	-	74
-77 -76 -72 -71 -6 -2 -1	PART NO	DESCRIPTION

QTY	DESCRIPTION	ITEM NO
-	-	84
-	-	83
-	-	82
-	-	81
-	-	80
-	-	79
-	-	78
-	-	77
-	-	76
-	-	75
-	-	74
-77 -76 -72 -71 -6 -2 -1	PART NO	DESCRIPTION

QTY	DESCRIPTION	ITEM NO
-	-	84
-	-	83
-	-	82
-	-	81
-	-	80
-	-	79
-	-	78
-	-	77
-	-	76
-	-	75
-	-	74
-77 -76 -72 -71 -6 -2 -1	PART NO	DESCRIPTION

QTY	DESCRIPTION	ITEM NO
-	-	84
-	-	83
-	-	82
-	-	81
-	-	80
-	-	79
-	-	78
-	-	77
-	-	76
-	-	75
-	-	74
-77 -76 -72 -71 -6 -2 -1	PART NO	DESCRIPTION

QTY	DESCRIPTION	ITEM NO
-	-	84
-	-	83
-	-	82
-	-	81
-	-	80
-	-	79
-	-	78
-	-	77
-	-	76
-	-	75
-	-	74
-77 -76 -72 -71 -6 -2 -1	PART NO	DESCRIPTION

QTY	DESCRIPTION	ITEM NO
-	-	84
-	-	83
-	-	82
-	-	81
-	-	80
-	-	79
-	-	78
-	-	77
-	-	76
-	-	75
-	-	74
-77 -76 -72 -71 -6 -2 -1	PART NO	DESCRIPTION

QTY	DESCRIPTION	ITEM NO
-	-	84
-	-	83
-	-	82
-	-	81
-	-	80
-	-	79
-	-	78
-	-	77
-	-	76
-	-	75
-	-	74
-77 -76 -72 -71 -6 -2 -1	PART NO	DESCRIPTION

QTY	DESCRIPTION	ITEM NO
-	-	84
-	-	83
-	-	82
-	-	81
-	-	80
-	-	79
-	-	78
-	-	77
-	-	76
-	-	75
-	-	74
-77 -76 -72 -71 -6 -2 -1	PART NO	DESCRIPTION

QTY	DESCRIPTION	ITEM NO
-	-	84
-	-	83
-	-	82
-	-	81
-	-	80
-	-	79
-	-	78
-	-	77
-	-	76
-	-	75
-	-	74
-77 -76 -72 -71 -6 -2 -1	PART NO	DESCRIPTION

QTY	DESCRIPTION	ITEM NO
-	-	84
-	-	83
-	-	82
-	-	81
-	-	80
-	-	79
-	-	78
-	-	77
-	-	76
-	-	75
-	-	74
-77 -76 -72 -71 -6 -2 -1	PART NO	DESCRIPTION

QTY	DESCRIPTION	ITEM NO
-	-	84
-	-	83
-	-	82
-	-	81
-	-	80
-	-	79
-	-	78
-	-	77
-	-	76
-	-	75
-	-	74
-77 -76 -72 -71 -6 -2 -1	PART NO	DESCRIPTION

QTY	DESCRIPTION	ITEM NO
-	-	84
-	-	83
-	-	82
-	-	81
-	-	80
-	-	79
-	-	78
-	-	77
-	-	76
-	-	75
-	-	74
-77 -76 -72 -71 -6 -2 -1	PART NO	DESCRIPTION

QTY	DESCRIPTION	ITEM NO
-	-	84
-	-	83
-	-	82
-	-	81
-	-	80
-	-	79
-	-	78
-	-	77
-	-	76
-	-	75
-	-	74
-77 -76 -72 -71 -6 -2 -1	PART NO	DESCRIPTION

QTY	DESCRIPTION	ITEM NO
-	-	84
-	-	83
-	-	82
-	-	81
-	-	80
-	-	79
-	-	78
-	-	77
-	-	76
-	-	75
-	-	74
-77 -76 -72 -71 -6 -2 -1	PART NO	DESCRIPTION

QTY	DESCRIPTION	ITEM NO
-	-	84
-	-	83
-	-	82
-	-	81
-	-	80
-	-	79
-	-	78
-	-	77
-	-	76
-	-	75
-	-	74
-77 -76 -72 -71 -6 -2 -1	PART NO	DESCRIPTION

QTY	DESCRIPTION	ITEM NO
-	-	84
-	-	83
-	-	82
-	-	81
-	-	80
-	-	79
-	-	78
-	-	77
-	-	76
-	-	75
-	-	74
-77 -76 -72 -71 -6 -2 -1	PART NO	DESCRIPTION

QTY	DESCRIPTION	ITEM NO
-	-	84
-	-	83
-	-	82
-	-	81
-	-	80
-	-	79
-	-	78
-	-	77
-	-	76
-	-	75
-	-	74
-77 -76 -72 -71 -6 -2 -1	PART NO	DESCRIPTION

QTY	DESCRIPTION	ITEM NO
-	-	84
-	-	83
-	-	82
-	-	81
-	-	80
-	-	79
-	-	78
-	-	77
-	-	76
-	-	75
-	-	74
-77 -76 -72 -71 -6 -2 -1	PART NO	DESCRIPTION

QTY	DESCRIPTION	ITEM NO
-	-	84
-	-	83
-	-	82
-	-	81
-	-	80
-	-	79
-	-	78
-	-	77
-	-	76
-	-	75
-	-	74
-77 -7		