

Series F3480/F3600



Specifications:

Rated Voltage: 480 VAC - 50/60 Hz
600 VAC - 50/60 Hz

Rated Current: 480 VAC - 9A to 608A
600 VAC - 8A to 600A

Current Overload: 6X for 8 seconds

Hi-Pot Test (1 min):	480VAC	600VAC
Line to Ground	2210 VDC	3150 VDC
Line to Line	2780 VDC	3150 VDC

Insulation Resistance: 1000 MΩ min. at 250 VDC

Ambient Temperature: 0°C to 40°C (32°F to 104°F)

Humidity Range: 0% to 95% R.H.

Termination:

- Wire
- Terminal Blocks
- Pressure Terminal Blocks

Weight: 3 to 65lbs (1.36 to 29.50kg)

Agency Approvals:



Designed to attenuate conducted interference in a small package providing excellent insertion loss, the F3480/F3600 series filters will provide effective EMC solutions up to 600A at 600VAC and power applications up to 360kVA. With effective noise suppression in the critical 150kHz-30MHz range, this advanced 2-stage filter line will support both Delta and Wye connected loads. Curtis three phase filters are designed to provide EMC solutions in many applications such as:

- Motor
- Motor Control Centers
- Facility Filters
- Uninterruptible Power Supplies
- Power Conditioning Units
- Laser Welders
- Automated Test Equipment
- Robotics
- CNC Machinery
- Elevators
- Industrial Ovens

F3480 Simplified Schematic

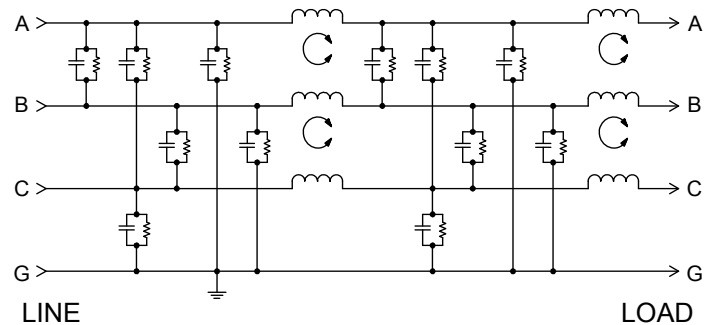

F3600 Simplified Schematic

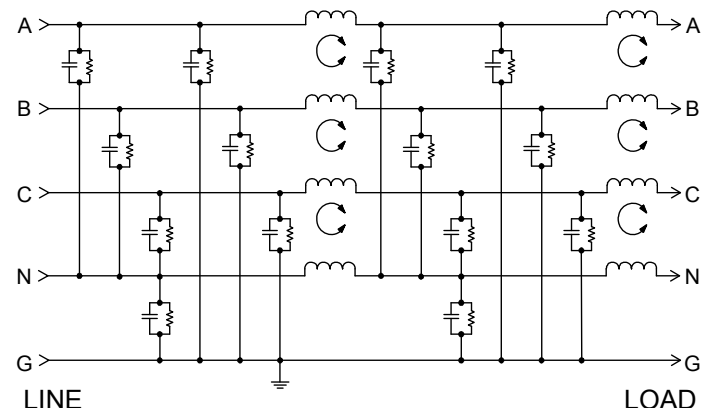

3-Phase Power Line Filters

Ordering Information:

F3600 T 600

3-Phase Series:
 F3480 = 480 VAC
 F3600 = 600 VAC

T = Terminal Blocks
 B = Wire Leads
 A = .250 Q.C. Terminal
 (8 - 50A Only)

Current Rating 008 - 608
 (Refer to Charts)

F3480 Series - 480 VAC																
Rated Current (Amps)	Part Number	Maximum Leakage Each L/G (250V, 60Hz)	Minimum Insertion Loss (dB)							Dimensions (Inches)						
			Frequency (MHz)							A	B	C	D	E	F	G
608A	F3480T608	140mA	Frequency (MHz)							18.75	5.25	5.93	41.25	16.00	8.00	.28 x .40
	.15 .5 1 5 10 30															
	CM		60	70	70	60	45	30								
	F3480B608		DM	30	40	40	35	30	20	18.75	5.25	4.50	--			
322A	F3480T322	90mA	Frequency (MHz)							10.50	5.25	4.63	23.50	8.00	4.00	.28 x .40
	.15 .5 1 5 10 30															
	CM		60	70	70	65	55	45								
	F3480B322		DM	30	40	40	40	35	20	10.50	5.25	4.50	--			
185A	F3480T185	90mA	Frequency (MHz)							11.25	4.12	4.25	20.25	10.00	5.00	.20 x .30
	.15 .5 1 5 10 30															
	CM		60	70	70	65	55	45								
	F3480B185		DM	30	35	35	45	40	30	11.25	4.12	3.50	--			
135A	F3480T136	80mA	Frequency (MHz)							8.50	4.12	4.25	16.00	7.00	3.50	.20 x .30
	.15 .5 1 5 10 30															
	CM		60	65	70	60	50	40								
	F3480B136		DM	25	35	45	30	30	20	8.50	4.12	3.50	--			
112A	F3480T112	80mA	Frequency (MHz)							8.50	4.12	4.25	16.00	7.00	3.50	.20 x .30
	.15 .5 1 5 10 30															
	CM		60	65	70	60	50	40								
	F3480B112		DM	25	35	45	30	30	20	8.50	4.12	3.50	--			
80A	F3480T080	30mA	Frequency (MHz)							8.50	4.12	4.25	16.00	7.00	3.50	.20 x .30
	.15 .5 1 5 10 30															
	CM		60	70	70	65	55	45								
	F3480B080		DM	15	25	45	40	40	30	8.50	4.12	3.50	--			
60A	F3480T060	30mA	Frequency (MHz)							8.50	4.12	4.25	16.00	7.00	3.50	.20 x .30
	.15 .5 1 5 10 30															
	CM		60	70	70	65	55	45								
	F3480B060		DM	15	25	45	40	40	30	8.50	4.12	3.50	--			
50A	F3480A050	15mA	Frequency (MHz)							8.00	5.12	2.25	--	5.00	--	.19 x .25
	.15 .5 1 5 10 30															
	CM		60	75	80	75	70	50								
	F3480B050		DM	10	40	50	50	50	40	8.00	5.12	2.25	10.10			
	F3480T050		Frequency (MHz)													
32A	F3480A032	7mA	Frequency (MHz)							8.00	5.12	2.25	--	5.00	--	.19 x .25
	.15 .5 1 5 10 30															
	CM		60	70	80	75	65	45								
	F3480B032		DM	10	45	50	50	50	40	8.00	5.12	2.25	10.10			
	F3480T032		Frequency (MHz)													
16A	F3480A016	3mA	Frequency (MHz)							6.00	3.88	2.00	--	4.00	--	.16 x .20
	.15 .5 1 5 10 30															
	CM		50	70	80	75	65	50								
	F3480B016		DM	10	50	50	40	40	40	6.00	3.88	2.00	10.10			
	F3480T016		Frequency (MHz)													
9A	F3480A009	3mA	Frequency (MHz)							6.00	3.88	2.00	--	4.00	--	.16 x .20
	.15 .5 1 5 10 30															
	CM		60	80	80	70	60	50								
	F3480B009		DM	30	45	50	50	50	50	6.00	3.88	2.00	10.10			
	F3480T009		Frequency (MHz)													

THREE-PHASE FILTERS

Dimensions are in inches and millimeters unless otherwise specified. Values in parentheses are metric equivalents.



Series F3480/F3600

F3480B & F3600B Dimensions

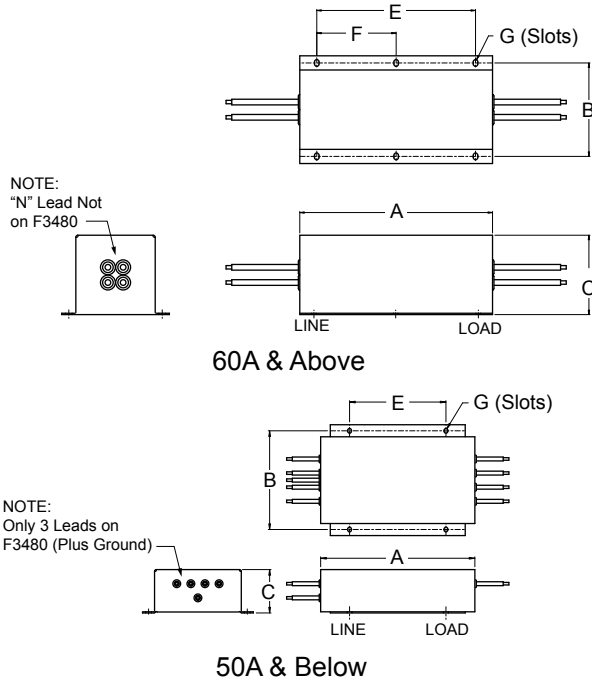

F3480T & F3600T Dimensions

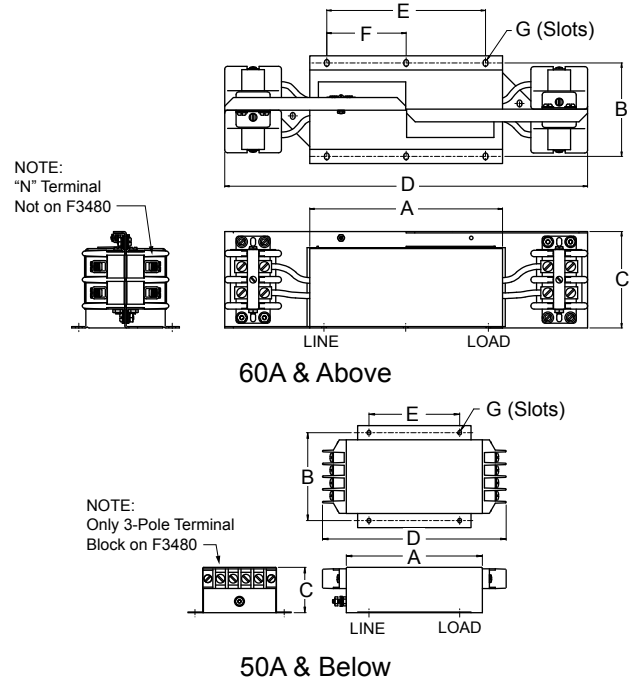

F3600 Series - 600 VAC

Rated Current (Amps)	Part Number	Maximum Leakage Each L/G (250V, 60Hz)	Minimum Insertion Loss (dB)							Dimensions (Inches)						
			Frequency (MHz)							A	B	C	D	E	F	G
600A	F3600T600	120mA	Frequency (MHz)							18.75	5.25	5.93	41.25	16.00	8.00	.28 x .40
	CM															
	DM															
300A	F3600T300	60mA	Frequency (MHz)							10.50	5.25	5.93	26.50	8.00	4.00	.28 x .40
	CM															
	DM															
180A	F3600T180	60mA	Frequency (MHz)							11.25	4.12	4.25	20.25	10.00	5.00	.20 x .30
	CM															
	DM															
80A	F3600T080	30mA	Frequency (MHz)							8.50	4.12	4.25	16.00	7.00	3.50	.20 x .30
	CM															
	DM															
45A	F3600A045	10mA	Frequency (MHz)							8.00	5.12	2.25	--	5.00	--	.19 x .25
	CM															
	DM															
25A	F3600A025	8mA	Frequency (MHz)							8.00	5.12	2.25	--	5.00	--	.19 x .25
	CM															
	DM															
16A	F3600A016	4mA	Frequency (MHz)							6.00	3.88	2.00	--	4.00	--	.16 x .20
	CM															
	DM															
8A	F3600A008	4mA	Frequency (MHz)							6.00	3.88	2.00	--	4.00	--	.16 x .20
	CM															
	DM															

